

Chicago Scene

APRIL 2004



CHILI TASTING/CONCOURS SCHOOL

PERMANENT NUMBER LIST

VEHICLE DYNAMICS WORKSHOP

MORE SWAP MEET INFORMATION

AUTOCROSSES I and II REGISTRATION INFORMATION

ALL THE BRANDS YOU TRUST.

INTRODUCING THE ALL-NEW WWW.NORTHSTARMOTORSPORTS.COM

Northstar
MOTORSPORTS

800.356.2080
ALL THE BRANDS YOU TRUST

BRAND SEARCH
Select a Brand

NEW PRODUCTS
Spaxo X Light 300 Nomex Driving Suit
This is the lightest 3 seat racing suit in the world. It is 20% lighter than previous models.
\$1199.00

THE NORTHSTAR ADVANTAGE
Northstar Motorsports has inspired the entire motorsports world with our unique store opening in 1990. We have had the pleasure of selling an immense number of top quality products and providing exceptional service to all customers.

SPECIALS & SALES ITEMS
Papet Racing Brake Pads
Buy any 3 sets or more -
15% Discount

Spaxo RaceCat Nomex Driving Shoes
Limited Availability
Retail \$129
Sale Price \$145

MAILING LIST
FREE SHIPPING
CLICK HERE TO LEARN MORE

FEATURED ITEM
Intercomp Drivard Lap Timer System
Includes 200 hp memory, dash marking, manual, transmitter, and carrying case.
\$299.00

Northstar
MOTORSPORTS
WWW.NORTHSTARMOTORSPORTS.COM
ORDERS: 800.356.2080 | TECH: 847.304.5515



Chicago Scene



Departments

- 19 Address Change Form
- 68 Aungahh!
- 13 Autocross Scene
- 8 Board Meeting Minutes - February
- 12 The Bulletin Board
- 2 2004 Calendar / Three Months At A Glance
- 20 Charity Scene
- 42 Club Racing Scene
- 64 Chicago Region 2004 Tech Inspection Form
- 22 The Goodie Store
- 27 Index of Advertisers
- 5 It's Why You Bought The Car
- 66 The Mart
- 17 Membership News
- 3 Officers, Directors & Coordinators
- 65 Oversteer
- 33 Q & A
- 26 Q-tip Corner - Concours Scene
- 6 Rallye Scene
- 29 The Straight Scoop - DE Scene
- 50 Technical Scene
- 57 Tech Quiz



Marla and Greg Turek's
1989 944 S2 Firehawk
at Gingerman Raceway

cover photo provided by
Marla and Greg Turek,
Courtesy of MNS Photo

April 2004 Features

- 28 Chicago Region 2004 DE Program
- 23 Chili, Concours & Hot Wheels
- 36 March Word Find Solution
- 54 The Midship Report: SWM (D) Seeks SWF (N)
- 52 Permanent Car Numbers
- 48 Places To Stay While Visiting Road America
- 44 RADE DE Event Letter
- 21 Safety - Keep Informed
- 6 Tulip Rallye Photos
- 11 Valentine's Day Social
- 60 Vehicle Dynamics Workshop

Event Announcements

- 41 Autocross I - May 23rd
- 63 Autocross II - Jun 27th
- 16 Autocross School - Apr 25th
- 31 Blackhawk Experienced DE - May 5th
- 37 Blackhawk Novice DE - May 12th
- 56 Blackhawk DE - Jun 11th
- 59 Concours I - Jun 13th
- 20 Driving Tour: Cruising the Flavors of Monroe -
May 1 - 2 CANCELLED
- 49 Kane County Cougars Baseball Game - June 5th
- 7 Photo Rallye I - Apr 18
- 46 RADE DE - May 28th - 30
- 51 Do We or Don't We ... Rallye II - Jun 6th
- 38 Swap Meet - May 22nd

Contributing to this issue: Jim Jacisin, Russ Pesko, Steve Rashbaum, Ed Barnicle, Toby Duckett, Ed Leed, Jim Drury, Debby Leed, Van Miller, Todd Conforti, Chuck LaMantia, Claude Reed, Van Larson, Pat Yanahan, John Ruther, Dan Metz, John Miller, Mary Anne Nowakowski, Jason Meredith

The **Chicago Scene** (ISSN 10564195) (USPS 0006-381) is the monthly publication of the Porsche Club of America (PCA) - Chicago Region, printed at PressTech, 959 Lee Street, Des Plaines, IL 60016-6545. Periodic Rate Postage paid at Des Plaines, IL USPS Subscription is provided to members of the PCA - Chicago Region. PCA dues are \$42.00 annually, of which \$12.00 is for the subscription. Subscription rate for non-Chicago Region members is \$24.00 per year. Permission to reprint any material published herein is granted, provided full credit given to **Chicago Scene** and the author. PCA - Chicago Region is not responsible for any services or products advertised herein. Statements appearing in the **Chicago Scene** are those of author and do not constitute an opinion of the PCA - Chicago Region or its Board of Directors.

All copy material must be received by the 1st of the month for publication in the next month's issue and will be published on a space available basis. The editor reserve the right to edit all materials submitted for publication.

Articles are preferred in MSWord. Do not send articles in pdf format. All digital photos should be taken at the maximum resolution the camera allows (minimum 300 dpi). File format may be tiff or jpeg.

Commercial Advertising Rates (per issue/billed quarterly)
Business card: \$75.00 One-quarter page: \$175.00
Half-page: \$250.00 Full page: \$450.00
Cover: not currently available

Susan Shire
Editor/Advertising Manager
ChiScene@aol.com
847.272.7764
Fax 847.272.7785
1897 Mission Hills Lane
Northbrook, IL 60062-5760

Send address changes to:
Postmaster
Bob Soske
PressTech
959 Lee Street
Des Plaines, IL 60016-6545
e-mail: Leedlast@hotmail.com

THREE MONTHS AT A GLANCE

2004 Calendar (as of 3/15/04)

Italics = info in this issue CAPS = change

Sun	Mon	Tue	Wed	Thu	Fri	Sat
	April 2004			1	2 BOARD MEETING	3
4	5	6	7	8	9	10
11	12	13	14	15	16	17
18 PHOTO RALLYE I	19	20	21	22	23	24
25 AUTOCROSS SCHOOL - Maywood Park	26	27	28	29	30	
May 2004						1 WISCONSIN RACING TOUR CANCELLED
2 WISCONSIN RACING TOUR CANCELLED	3	4	5 BLACKHAWK DE EXPERIENCED ONLY	6	7 BOARD MEETING	8
9	10	11	12 BLACKHAWK DE NOVICE ONLY	13	14	15
16	17	18	19	20	21	22 SWAP MEET
23 AUTOCROSS I Hawthorne Race Track	24	25	26	27	28 RADE - INSTRUCTORS & NOVICES	29 RADE
30 RADE	31 	1	2	3	4 BOARD MEETING	5 KANE COUNTY COUGARS GAME
June 2004						
6 RALLYE II	7	8	9	10	11 BLACKHAWK DE	12
13 CONCOURS I MedinahCC	14	15	16	17	18	19
20	21	22	23	24	25	26
27 AUTOCROSS II - Rockford Speedway	28	29	30			

Apr

- 18 Photo Rallye I
- 25 Autocross School

May

- 1-2 ~~Driving Tour - Cruising in Monroe~~
- 5 Blackhawk DE-Experienced Only
- 12 Blackhawk DE-Novice Only
- 22 Swap Meet
- 23 Autocross I
- 28-30 RADE 2004 DE

Jun

- 5 Kane County Cougars Game
- 6 Rallye II
- 11 Blackhawk DE
- 13 Concours I
- 27 Autocross II - Rockford Speedway

Jul

- 4-10 Porsche Parade
- 18 AUTOCROSS III - MGA
- 23 Blackhawk DE
- 25 POTTER'S PICNIC/CONCOURS II
- 31 Golf Outing

Aug

- 1 Cuneo Concours III
- 7-8 Gingerman DE
- 15 Rallye III
- 18 Blackhawk DE
- 22 Autocross IV - Lake Geneva

Sep

- 3-6 TRAC 2004 DE & Club Race
- 4 TRAC 2004 Concours IV
- 5 TRAC 2004 Dinner & Party
- 12 Rallye IV
- 15 Blackhawk DE
- 19 Autocross V - Maywood Park
- 26 Concours V & Charity Event

Oct

- 2-3 Blawhawk Octoberfest DE
- 16-17 Rallye V
- 23 Concours Judge's School

Nov

- 6-7 Driving Tour in MI
- 14 Tech Session

Dec

- 11 Dinner Dance

2004 CHICAGO REGION OFFICERS AND BOARD OF DIRECTORS



President
Jim Jacisin
630.279.4835 (h)
630.665.3491 (f)
james@design-dept.com



Vice President
Chris Inglot
847.559.1126 (h)
773.286.4811 (f)
CInglot@aol.com



Secretary
Ed Barnicle
630.323.2963 (w)
630.323.5334 (f)
ebarnicle@dolphincartage.com



Treasurer
Jack Stephensen
708.865.1465 (v)
847.541.6171 (f)
jstephensen@aol.com

2004 COORDINATORS



Past President
Keith Clark
630.690.3381 (h)
630.690.3394 (f)
ClarkFNFlying@aol.com



Director
Todd Conforti
847.952.0070 (w)
847.952.1261 (f)
tlcontrols@aol.com



Director
Pete Hackenson
630.655.1629 (h)
630.655.4841 (f)
P.Hackenson@comcast.net



Director
Mary Anne Nowakowski
847.929.1831 (w)
847.470.1204 (f)
nowakowskim@permapipe.com



Director
Ken Pesavento
630.469.1546 (v)
Kenneth_a_Pesavento@ml.com



Director
Steve Rashbaum
847.272.7731 (h)
847.272.7785 (f)
SRashbaum@Invitrogen.com

Autocross - Jeff Girard

815.838.3000
dukiemaxgirard@aol.com

Autocross Tech/Registration - Mike Hill

708.415.0769
michael@mphproductions.com

Charity - Jim Drury

708.354.8121
JamesDrury@ameritech.net

Chicago Scene - Susan Shire

847.272.7764
ChiScene@aol.com

Chief Driving Instructor - John Ruther

847.304.5515
chief_instructor@pca-chicago.org

Concours - Van Larson

630.377.4686
Valyr9090@aol.com

Concours - A J Tiller

312.735.8771
aj2manycars@aol.com

Database - Ed & Debby Leed

847.382.6911
leedlast@hotmail.com

Blackhawk DE - Dan Gallagher

708.784.0784
bbabies@aol.com

Blackhawk DE - Pete Hackenson

630.655.1629
P.Hackenson@comcast.net

Gingerman DE - Jeff Girard

815.838.3000
dukiemaxgirard@aol.com

RADE 2004 - Pete Hackenson

630.655.1629
P.Hackenson@comcast.net

RADE 2004 - Keith Clark

630.690.3381
ClarkFNFlying@aol.com

DE Tech - Toby Duckett

630.248.7680
toby@mc2fyi.com

DE/TRAC Reservations - Nick Brenkus

847.426.9111
nsbrenkus@prodigy.net

Goody Store - Chuck LaMantia

630.510.7418
claman1022@msn.com

Goodie Store - Keith Clark

630.690.3381
ClarkFNFlying@aol.com

Historian - John O'Keefe

708.531.9116
jdok911@aol.com

Insurance - Keith Clark

630.690.3381
ClarkFNFlying@aol.com

Membership - Van Miller

847.949.0972
Quik550@aol.com

Novice Driving Instructor - Ed Leed

847.382.6911
leedlast@hotmail.com

Photography - Russ Pesko

630.759.2099
porsche575@comcast.net

Property - Ed Leed

847.382.6911
leedlast@hotmail.com

Rallye - Tom & Phyllis Harwood

847.742.6804
TRH911sc@aol.com

Rallye - Ken Pesavento

630.469.1546
Kenneth_a_Pesavento@ml.com

Safety - Todd Conforti

847.952.0070
tlcontrols@aol.com

Social - Chuck & Melissa LaMantia

630.510.7418
claman1022@msn.com

Timing & Scoring - Chuck Bittman

708.352.9505
cbittman@bellebotanicals.com

Timing & Scoring - George Schaefer III

708.562.5908
Georgetheiii@bureauhq.com

TRAC 2004 - Pete Hackenson

630.655.1629
P.Hackenson@comcast.net

TRAC 2004 - Keith Clark

630.690.3381
ClarkFNFlying@aol.com

TRAC 2004 Race Tech - Todd Conforti

847.952.0070
tlcontrols@aol.com

Webmaster - Greg Gulik

312.642.5377
webmaster@pca-chicago.org

Zone 13 PCA Rep - Butch Raiha

217.877.6874
raiha@aol.com

EUROSPORT *Racing*



Tim McKenzie 69 - GT4R - 1st Overall - Sprint
1st in Class / 4th Overall - Enduro

Steve Pattee 31 - GT4S - 3rd Enduro



Gary Knoblauch - GT4S - 1st Sprint



Chris Inglot - F - 2nd Sprint & 2nd Enduro



J. Gold - C - 3rd in Class / 4th Overall Enduro

Team Eurosport Wins Big At Sebring 2004

Claude Reed - G - 2nd Sprint & 3rd Enduro



Bob Klaskin - E - 2nd Enduro



Rob King - D - 3rd Sprint



BOSCH MOTEC Systems Hoosier Tires JRZ Shocks Fikse Wheels Recaro Seats

- Street, Autocross & Race Car Prep
- Engine Development & Dyno Testing
- Performance Modifications & Tuning
- Alignment & Corner Balancing
- Custom Exhaust & Tuning
- Transport & Support for Driver's Ed & Club Racing Events
- MOTEC Fuel Injection & Data Logging

**PORSCHE :SERVICE
:PARTS
:ROAD RACING**

**BOSCH :ELECTRICAL
:BRAKES / ABS
:FUEL SYSTEMS**

WWW.MIDWESTEUROSPORT.COM

**104 W. IRVING PARK RD. BENSENVILLE, IL 60106
PHONE: 630-595-5577 FAX: 630-595-8096**

It's Why You Bought The Car

by Jim Jacisin, President

Really Why You Bought It

You stand in line, patiently waiting your turn. You can see the ride, hear it, even feel it. But until you're actually on it, there is nothing like the experience. When you're on a rollercoaster, along your way up, you hear all the safety equipment clanging from under the rails to keep you from falling. Well, that has been all the school and hard work that has prepared us for the year ahead. We've learned to Auto-cross, Concours, Rallye, keep things safe and track our cars. We're ready, up to a point.

Remember on a rollercoaster when that rhythmic clanging stops? You're at the top looking precariously at the drop below. And what happens? They hang you up there intentionally for a moment just so it's clear to you and everyone else that something terribly exciting is about to happen, something a little dangerous that will take your breath away, something that once you start, nothing on this earth will stop it.

Welcome to April. This is truly the calm before the storm. From now until the end of the year is the thrill ride of a lifetime. It really is why you bought the car.

Looking forward...

Our first for points rallye is Sunday, April 18th. It is a popular Photo Rallye put together by first time Rallyemaster, Ed Barnicle and long time Rallyemaster, Dan Gallagher. Oh, to have been a proverbial fly on the wall in that car as they laid out this rallye! If the General Instructions are in Gaelic, Cindy and I are in great shape. Come for the rallye, stay for the blarney.

Next up is the ever popular Auto-cross School, aka *watch the president run over innocent yellow and orange cones*. No matter your skill or

lack thereof, this is a do not miss event. If you plan on driving a road course, an autocross or just want to become a better instinctive driver, do not miss this event. If you do just one thing in this club (besides come to a Concours), I repeat, come to this event.

Looking back...

Thank you Greg Turek and John Ruther for hosting the Vehicle Dynamics Workshop in Naperville. I understand that this event sold out very quickly and was appreciated by all.

Next up was our annual St. Patrick's Day party hosted by Bonnie Yanahan. Think corned beef and billiards meets RiverDance. Thank you, Bonnie.

And finally, Ken Pesavento along with Tom & Phyllis Harwood hosted our annual Rallye School at Medinah Country Club. Again, we had an over-flow house



Jim Jacisin at the February Board Meeting

photo by Steve Rashbaum

and a well-run classroom followed by a show-what-you've-learned practice Rallye immediately afterward. Thanks guys.

So strap it down and cinch it up, hands inside the car, we're all in for a ride. The keys are waiting, get out there.

Please note the **DATE CHANGE** for the **APRIL BOARD MEETING** to **FRIDAY, APRIL 2nd**.

MANNY'S
PERFORMANCE, INC

16651 VINCENNES AVE. • SOUTH HOLLAND, IL 60473

Servicing, modifying, racing and restoring
Porsche cars since 1964

708-333-6606

By appointment only
WE DO IT RIGHT - THE FIRST TIME!

Rallye Scene

by Tom and Phyllis Harwood and Ken Pesavento, 2004 Rallye Coordinators

What Is A Rallye?

A rallye is not a race, rather it is a contest in which a team consisting of a driver and a navigator combine their driving, observational, mathematical, and communicative skills (as well as patience) in the negotiation of a prescribed road course at prescribed speeds. The main objective is to stay on course following a set of route instructions. A rallye can be competitive or for fun. (Please see the 2004 Directory for Rallye Classes and Notes.)

2004 Rallye Schedule

Mark your calendars!

Apr 18 Photo Rallye I*

Jun 6 Rallye II*

Aug 15 Rallye III

Sep 12 Rallye IV

Oct 16 - 17 - Rallye V

*Event Announcements in this issue of the Chicago Scene

Need a Rallye Partner? Call Tom, Phyllis, or Ken and they'll see what they can do for you.

For further information about Rallyes contact:

Tom or Phyllis Harwood,
847-742-6804
trh911sc@aol.com

Ken Pesavento,
630.469.1546
kenneth_a_pessavento@ml.com

Tulip Rallye Photos (Porsches not required)

photos by Russ Pesko



The Bacins in the latest "Bacin-mobile"



Mike and Debby Strain set out in search of elusive "tulips".



Dan Gallagher at Checkpoint #1 ... Thanks Dan for another fun and informative rallye!



Spring is sprung,
 The grass is riz
 I wonder where the
 Santa Fe Speedway is?
TSD Photo Rallye



PCA CHICAGO REGION

Sunday, April 18th

PLACE: Bucks Pit Stop
 6701 Kane
 Hodgkins, Illinois
 708-588-0895

Non-Porsches may participate

To qualify for year-end points,
 participants must drive a Porsche

REGISTRATION 10:00 am
DRIVER'S MEETING 10:30 am
FIRST CAR OFF 11:01 am

Entry fee: \$20.00 per car

Dan Gallagher and Ed Barnicle present a 100% finishable rallye for the 1st rallye of the season. Last year 37 cars started this rallye and all 37 finished. The idea is simple: match the photo to the intersection and follow the instructions. The rallye is less than 100 miles and along the way you will be looking for the Santa Fe Speedway

The beginning and end points of this rallye is Bucks Pit Stop - a NASCAR oriented neighborhood tavern with good food. The midpoint/break will be at Stonecutters in Lamont

Dinner is at 5:00 pm (Dinner order to be placed at Registration).

Directions to Bucks:

From the North: I-294 South, Exit St. Louis Exit, pay 15-cent toll; take middle fork to Joliet Road East, take Joliet East for approximately 3 miles to East Avenue (T). Right (south) on East 0.7 miles, left on Lyons 4 blocks to Bucks.

From the South: I-294 North exit at the St. Louis Wolf Rd. Exit, stay to the left for Wolf Road Exit; right (north) on Wolf for 2 blocks to Joliet Rd.; right on Joliet Rd. (east) approximately 2 miles to East Avenue (T). Right (south) on East 0.7 miles, left on Lyons 4 blocks to Bucks.

From the East: I-55 (Stevenson) west to LaGrange, exit LaGrange Rd. north. Go approximately 1/4 mile and then right on 67th Street (east). Take 67th approximately 1/2 mile to East Avenue, left (north) on East Avenue 2 block to Lyons, right on Lyons (East) 4 blocks to Bucks.

From the West: I-55 Stevenson east, exit Joliet Rd (Exit 276C on your left); proceed straight (east) on Joliet approximately 3 miles to East Avenue (T). Right (south) on East 0.7 miles, left on Lyons 4 blocks to Bucks.

Questions: Call Dan Gallagher at 1-708-784-0784 or bbabies@aol.com.

Mail Registration to Dan Gallagher, 11156 Indian Woods Drive, Indian Head Park, IL 60525

Make checks payable to PCA Chicago Region

 DRIVER

 phone/e-mail

 NAVIGATOR

 phone/e-mail

Board Meeting Minutes: February 13, 2004

Respectfully submitted by H Edward Barnicle, Secretary

photos by Steve Rashbaum

Voting Members Present:

Jim Jacisin, Ed Barnicle, Jack Stephensen, Ken Pesavento, Steve Rashbaum, Keith Clark, and Pete Hackenson

Coordinators Present:

Phyllis Harwood, Tom Harwood, Dan Gallagher, Van Miller, Susan Shire, John O'Keefe, Toby Duckett, Ed Leed, Chuck LaMantia, A. J. Tiller, and Jim Drury

Members Present:

Jim Hopp, Brent Johnson, Kurt Konrath, Bob Danko, and Mark Palmer

Meeting Called to Order by Jim Jacisin at 8:05 pm at Park Ridge VFW Hall, Park Ridge, IL

Secretary: No Report.

Treasurer: Jack Stephensen presented our financial statement showing that the treasury grew in 2003. Also included was a P&L statement for the entire year, and he noted that the necessary deposits for Blackhawk and the May Road America event had been made.

- Clark motioned to accept the report. Hackenson seconded. Passed unanimously.

Vice President: No Report.

President: Jim Jacisin reported that the General Membership Meeting went well, and that the Marriott Hotel was going to send us a refund for the Calendar Planning Meeting as a gesture to gain future business. He noted that the PCA RPM for coordinators and event chairs is a

valuable guide for those who are new on the job. Chris Inglot is also preparing a guide. Greg Gulik wants the autocross, rallye, and concours coordinators to e-mail their dates to him for posting on the website. Finally, he reported that the Pay Pal is ready to go, and asked Jack Stephensen to contact Greg Gulik.

Autocross: No Report from Jeff Girard. Ed Leed reported that the Novice Autocross School was basically all set. It will be held on 4/25/04 at the Maywood Park Race Track; and he needs experienced autocross, DE, and/or Club Racers to volunteer to teach. Entry fee will be \$30.00.

Timing & Scoring: No Report.

Road America: Pete Hackenson reported that Road America raised fees for the Memorial Day event by 3%, and the Labor Day event by 5.8%. However, some items that had been additional charges for the Labor Day event are now included in the fee. Both events are on schedule.

Blackhawk Farms: Dan Gallagher reported that all is set for this year except for insurance which will be handled by Keith Clark. The region will now be the primary insurer which is different from the past few



Coordinators (from the left) Ed Leed, Database; Jim Drury, Charity; A J Tiller, Concours; and Director Ken Pesavento

Having fun at the February Board Meeting



(above) Treasurer Jack Stephensen



(left) Membership Coordinator Van Miller



(from the left) Tom and Phyllis Harwood, Rallye Coordinators, Chuck LaMantia, Goodie Store and Social Coordinator, and Jim Hopp

years when we were secondary. The first event for experienced drivers will be on 5/5/04, followed by the Novice School on 5/12/04. This year's entry fee will be \$170.00.

Gingerman: No Report.

Chief Driving Instructor: No Report.

Insurance: Keith Clark stated that he won't have this year's insurance info from PCA National until mid-March. He reminded coordinators and event chairs that waiver sheets must be completed ASAP, and turned in for submission to National. The major change for this year is that every event, not just those that turn wheels, will be insured.

Concours: A. J. Tiller reported the prizes are ready for the Chili Tasting and R.C. Cars Event. He reported that all dates and locations for this year's Concours are set, except for Potter's Picnic which might change per a request from the Autocross coordinator. He also reported that the Concours scheduled for the Medinah C.C. might require a higher entry fee or a subsidy from the region because Medinah was firm in their price of \$28.00 for the luncheon buffet. More to come at the next board meeting.

Rallye: Gallagher reported that he will have about 16 cars for the Tulip Rallye. The Harwoods reported that PCA National wants to borrow the region's rallye clocks for Parade. They said that they would transport the clocks to and from Parade.

- Jacisin moved to approve the request as long as they replaced all the batteries. Rashbaum seconded. Passed unanimously.

Pesavento reported that the trophies for all of this year's events had been ordered, and would cost less than last year.

Social: Toby Duckett reported that all is set for Valentine's Day Party @ Shaw's Crab House in Schaumburg. Chuck LaMantia reported that he had secured a 6/5/04 date for an outing to the Kane County Cougars

game that day. In order to get the desired package deal, the region must commit to a minimum of fifty tickets. Chuck is also looking at a possible date for an outing to Ravinia.

Membership: Van Miller reported that we have 22 new members since the November board meeting.

Safety: No Report.

Technical: Toby Duckett reported that all is set for the Spring DE Tech Session, and that he is looking forward to a year of completely safe DE events. He encourages all DE entrants to get their cars teched by an authorized service center each month, and to bring their log book to each event. This will allow the drivers to use the "Fast" tech lane except at Road America which will require its own tech.

Goodie Store: Chuck LaMantia distributed a current inventory list of items for sale. The list also included his estimate of a small profit, and said that warm weather items will be ordered as the year progresses. He will have items for sale at the Chili Tasting, Rallye School, and Autocross School.

Charity: Jim Drury began by saying that Kirstin Knott has been especially helpful with collecting charitable donations at track events. He reported that the Exchange Club of Naperville wants us to come to their Grand Prix event this year, and wants to create some rivalry between the various car clubs that will be attending and participating in the driving event. Jim will ask the Dieke Eye Center, his choice for this year's charity, to attend next month's board meeting. There is info in the Scene regarding a two-day charity tour to the attractions in and around Monroe, WI.

Chicago Scene: Susan Shire reported that she has made tremendous strides in getting advertisers to pay their past-due invoices, and to pay the current ones promptly. Our thanks to those who pay on time.

Property: No Report.

Sponsorship: No Report.

Photography: No Report.

Historian: John O'Keefe mentioned that long-time Chicago member Gene Busian was moving out of the region..

- Steve Rashbaum moved to make Gene an honorary lifetime member of the region. Pete Hackenson seconded. Passed unanimously.

Webmaster: No Report. Site is current.

Old Business: None.

New Business:

Keith Clark and Pete Hackenson reported an idea to offer a rebate to those regions that have a lot of members attending the Labor Day Event at Road America. There was a suggestion that the number of forums on the website be reduced to one. Pete Hackenson spoke at length about DriverRegistration.com, an up-and-coming website developed by a PCA member from Florida. He said that the advantages of this system might be worth more than the cost which he estimated at \$3000.00 annually, and suggested we try it for a Blackhawk Event. More to come. Dan Gallagher suggested that a list of past winners of the New Member Enthusiast of the Year, Enthusiast of the Year, Family of the Year, and the Wayne Potter awards be developed and published annually in the Region Directory. John O'Keefe will research, and report back to the Board.

Motion to Adjourn: Steve Rashbaum
Second: Pete Hackenson
Approved Unanimously

Adjournment: 10:00 PM

Next meeting: Friday April 2nd

This is a date change from the previously published calendar

WE GO THE DISTANCE FOR SUPERIOR SERVICE

**VEHICLE MAINTENANCE & PERFORMANCE
AUDI BMW MERCEDES PORSCHE VW**

KELLY MOSS MOTOR SPORTS

★ ★ ★ ★ ★



**STREET CAR
MAINTENANCE**



**RACE CAR
PREPARATION**

**TRANSPORTATION
SERVICES**



**MODIFICATION &
BUILDING**

**PAINT &
COLLISION REPAIR**



VINYL GRAPHICS



CHECK OUT OUR WEBSITE AT:

www.kellymoss.com

**3017 PERRY STREET
MADISON, WI
53713
608.274.5054**

Valentine's Day Social

by Toby Duckett

Shaw's Social Feb 14, 2004

I want to thank all the 49 people that attended the special social at Shaw's Crab House, Feb. 14. Yes, I said 49. If I was smarter, I would have had a camera at the event, so my great verbal presentation will have to do.

The event was highlighted by three kisses. One to our country, one to our wonderful Porsche Cars, and the greatest and best to our special loved ones attending with us that either enjoy driving with us or at least let us spend some attention to the 4 wheel passion.

At no great expense, two great door prizes were handled out along with

the flower center pieces. The Shaw's staff did a great job getting the right food to the right people. I can not forget to thank my daughter Christie who did the table place settings cards with the names, a special heart and welcome and the food order. I hope all of you saved them for your next year's dinner.

Shaw's provided the 15% discount coupons to each party for a future visit. Even with that, they want us back anytime.

It was a great social event that we all enjoyed. Be sure to attend one of our several great social event during the year.



Toby "I forgot my camera" Duckett (at the General Membership Meeting)

photo by Steve Rashbaum

R FISCHER MOTORS IS PROUD TO PRESENT OUR ...

ANNUAL TEST & TUNE DAY

WHERE? GINGERMAN RACEWAY

WHEN? APRIL 19, 2004

COST? \$135.00 (includes trackside assistance)

PLEASE CONTACT PETER or RICK AT 847-304-8822 TO MAKE YOUR RESERVATIONS OR IF YOU HAVE ANY QUESTIONS

The Bulletin Board

Notes, e-mails, and info from other Regions, National, various websites, and the rest of the universe ...

Celebrate 20 Years of GRM and Classic Motorsports Magazine's First Anniversary

Celebrate 20 Years of GRM and Classic Motorsports Magazine's First Anniversary at Road Atlanta on May 1-2, in conjunction with HSR's Classic Motorsports Walter Mitty Challenge. Grassroots Motorsports Magazine will be celebrating 20 years - and Classic Motorsports Magazine will be celebrating its first anniversary - in the heart of the action at Road Atlanta. Event.

Highlights will include the Kumho Tires MINI Cooper Challenge (where attendees can try their auto-cross skills behind the wheel of a new MINI), on-track activities/ sponsored by the Tire Rack (hot laps

and parade laps), concours judging and car club corrals.

B.S. Levy, author of "The Last Open Road" and Classic Motorsports columnist, will be on hand. Carl Heideman and his British Motor Trade Association will be organizing a variety of technical seminars, and Champion Motor Cars will be building one of their incredible Lotus Super 7 replicas in the infield for all to see. A variety of CMS and GRM project cars will be on display.

Have something to sell? Swap meet space is free to all paid entrants, and there will be a special area set aside for those looking to sell a car.

For more information check out the party page at www.grassroots-motorsports.com/party.php

Mid America Direct's First Annual "Get Your Parts Before Summer Starts" Swap Meet

Get the parts you need for your Corvette, Porsche, Classic Volkswagen and New Beetle.

Saturday, April 3, 2004 • 8 a.m. to 3 p.m.
Mid America Corporate Campus, Effingham, IL.
(Visit www.madirect.com for directions)

- **Reserve Your Exhibitor Space Today** - Call 800-500-8333 or register online at www.madirect.com
- **20'x20' Exhibitor Spaces:** \$50 each (non-refundable), limit two spaces.
- **NO Commercial Exhibits:** All private sellers - only Corvette, Porsche and Volkswagen parts, accessories, or memorabilia allowed for sale.
- **Scratch & Dent Area:** Mid America will sell returned, scratched, and discontinued parts at discount prices.
- **Catalog Sales:** Orders from any Mid America catalog will receive 10% off, plus free ground shipping.
- **FREE** admission to the public!
- **Sell Your Car!** "Car Corral" registration is \$25 per vehicle (non-refundable), limit 2 spaces.
- **Shipping Available:** For your convenience, you can ship purchases if you do not want to transport the items yourself.



RESERVE YOUR SPACE TODAY!



YOU'RE INVITED...

Please Accept This Invitation To Our
**Certified Porsche
Inspection Clinic**

Saturday, April 24th, 2004
8:00am - 3:00pm

**Free Service
Inspection**

Complimentary Lunch and Gifts
For All Who Attend

Please RSVP:
Contact Our Service Department



PORSCHE

Joe Rizza Porsche

159th St. & 80th Ave. • Orland Park, IL
708-403-0300



Autocross Scene: A Day In the Life of An Autocrosser

by Ed Leed

Last month, Lee Lichtenstein gave us an overview of the sport of autocrossing. This month, it is my turn. In this article, I will go into more detail about some of the things you can expect at Chicago Region autocrosses.

Realistically, reading this article can only do so much. To really get the full measure of excitement and fun of an autocross, you should enter an event. Start with our Autocross School on Sunday, April 25th. Winning or losing is not important, especially when you are a beginner. For most of us, the camaraderie and socializing that occurs at an autocross is as much fun as the competition.

What is an Autocross?

Porsche Club Autocross events are low to medium speed racing events run on large parking lots and local oval tracks such as Rockford and Lake Geneva Speedways. You will drive your Porsche, one car at a time, through a course that is marked by rubber traffic cones.

Autocrossing is a test of precise driving skill, quick reflexes and strategy more than horsepower. Each competitor is timed and the fastest time through the course wins the class. It is not a dangerous event because the speeds are relatively slow, with speeds averaging about 30MPH with bursts of up to 60MPH. If 30MPH sounds boring to you, you are wrong. While you are competing it feels like you are going 100MPH because the tight and twisty course comes at you quickly. The typical lap time is about 1 minute. Penalties are assessed for knocking down a pylon cone so precision is demanded.

Autocrossing is an inexpensive, safe way to experience auto racing competition. Since there are no other cars with you on the course, the only thing you might hit is a

rubber pylon cone. Autocrossing helps you develop your own driving ability and to learn your car's capabilities and limitations, which can make you a better driver on the street. Many of our PCA Club Racers started in autocrossing, progressed into Driver Education events and then graduated into the sport of wheel to wheel road racing. In autocrossing, as in road racing, the greatest thrills are the challenge of beating your competitors and beating your own time.

For PCA autocross events, no competition license is necessary. If your Porsche is stock, and you plan to compete on your street tires, all you really need is your Porsche, a Snell approved helmet, a tire pressure gauge, your PCA membership card, a valid driver's license and your entry fee.

At all Chicago Region events, the use of drugs or alcohol is prohibited, whether you are driving or not. This includes your family and guests. We get high from adrenalin.

Registration

It helps with our event planning if you pre-register for each autocross and it saves you the late fee. At big events, pre-registering assures that your entry will be accepted provided your car passes tech inspection. When you arrive at the autocross site, the first thing you must do is register. There, you will be asked to sign the waiver, show your PCA membership card and valid driver's license. The registrar will collect your entry fee if you did not pre-register.

Your Porsche will be classified into one of the eleven classes listed in your 2004 Chicago Region Membership Directory. If you are unsure of your class or you have modified your Porsche, ask someone to help you determine the proper class for your car.

Generally speaking, if your Porsche is stock, you can improve your suspension, exhaust, wheels and tires and still be allowed to compete in your proper stock class without penalties for modifications. Our autocross classes are based on the PCA Parade Competition Rules found on the PCA national website, www.pca.org. There you will find the legal upgrades you can make as well as the points assigned to performance enhancing modifications. If you are a beginner, you will soon discover that your Porsche's capabilities far exceed yours. I recommend you wait a while before making modifications in an effort to go faster. A suspension upgrade will not help someone who is not yet competent driving the fastest line through a corner.

Technical Inspection

After you have registered, your Porsche will go through a technical inspection after which a tech approval sticker will be glued to your windshield. You are responsible for the safe condition of your car, so go over it yourself or have a mechanic inspect it.

The technical inspection form is found elsewhere in this issue of the Chicago Scene as well as posted on the Chicago Region Website, www.pca-chicago.org. It is the same form that you will sign at an autocross event. Use it as a guide to what will be scrutinized. The inspection of your Porsche at the autocross event is a cursory check of lug nut torque and obvious, visible items like tires, brake pads and leaks. Generally, if you know that your car is roadworthy, it should pass an autocross technical inspection. If you suspect that a component may be fatigued due to an accident or age, have it inspected in advance by a professional. Do not take a chance. The club takes no responsibility for your mechanical

Autocross ...

failure because it is impossible at an event to perform the thorough inspection made possible by raising your car on a hoist.

Before you take your Porsche to the tech inspection area, clean out the interior and trunk. Remove everything, including the floor mats. Clear out the glove box, too. This will make sure you won't be distracted by stuff flying around your passenger compartment while you're on the course. There can't be anything worse than having a flashlight roll out from under your seat and wedge itself under your brake pedal.

Before you leave home, adjust your tire pressure to the factory recommended pressure while the tires are cold. When you get to the autocross site, ask one of your competitors what they recommend for your model Porsche. If necessary, adjust the air pressure. Someone usually has an air tank or can direct you to the closest service station. Tire pressure settings, by the way, seem to be a common discussion topic among autocrossers, so don't be afraid to ask. You can expect a confusing array of well intentioned suggestions, so at first you may decide to leave your tire pressures set at the factory recommendations.

Safety Equipment

We do not require competition driving suits, gloves or shoes. Besides a Snell approved helmet dated 1990 or newer, the only requirements are trousers, a long sleeve shirt made of cotton or non-synthetic material and closed toe shoes, not sandals. Roll bars are not required. You do not need a competition harness, either. However, you will discover that your factory seat belts will not hold you securely in a turn because they do not lock unless you are decelerating. While you are slipping around in your seat you will be

distracted trying to control your car. So pretty soon, you will be installing a harness. A fire extinguisher is recommended but not required. It should be mounted within your reach inside the passenger compartment, ideally in the passenger foot well.

Tires

The tires on which you drive to the autocross will be just fine for your first autocross season. The harder compound of a street tire does not have the high grip of a high performance racing tire, but you have a lot to learn before you need to spend big bucks on a set of sticky gumball tires. Another favorite bench racing topic of conversation is tires, so ask any of your fellow competitors about the brands that work well on your model Porsche. Many high performance street tires are competent autocross competition tires and provide good durability for street driving. This means you will not need to buy an extra set of wheels and tires.

Walk the Course

As soon as you finish your tech inspection, park your car and walk the course from start to finish. Walking the course is one of the most important things you can do to learn the course layout and prepare for your runs. As you walk the course, visualize the line you will use as you approach, brake, turn and accelerate through the gate or turn. Buddy up with someone and discuss various strategies to drive the course. In the spirit of friendly competition you will find that

everyone shares their ideas about the best line through the gates and turns. While you are walking, draw a map of the course that you can study later.

The course may be difficult to visualize at first. To help guide our competitors, Chicago Region uses orange and yellow pylon cones to mark the right and left sides of the course. Don't be upset if you go "off course." Yes, your run will be disqualified if you miss a gate, but every one of us has done it, sometimes numerous times at a single event. Learning and following the course is one of the many exciting challenges of autocrossing. And to throw another wrinkle at you, the course is different at every autocross.

Driver's Meeting and the Day's Schedule

A drivers meeting is held before the competition begins. At the meeting, the groups and schedule will be announced. At most of our autocrosses, you will get a total of six runs, depending on the weather and number of entrants. We will run two separate sessions of three runs each for your class and group. Between runs when you are not driving, you will be required to work on the course chasing fallen pylons or helping with grid or timing. At Chicago Region events, you will be required to complete all of your runs with your class. If mechanical problems prevent you from running during your session, notify the event chair immediately. The event chairman may allow you

914 Limited



Maintenance, repair, restoration,
track preparation, new and used parts
exclusively for your 914

Brad Mayeur, PCA since 1974

Peoria, IL. 309-694-1797

veldiadv@midwest.net fax:309-698-2203

Pickup and delivery available

to compete later, as long as your competitors agree.

Taking your runs

You've heard the saying, Get in, strap up and hang on! Well, now it's show time! Your heart will be pounding and adrenalin rushing when you tighten your seat belt and put on your helmet. As excited as you are while you wait for the line to move up to the starter, now is the time to review your strategy. Visualize how you will drive the course. And when the starter tells you to go, it's time to launch your Porsche as quickly as possible.

Chicago Region uses a rolling start with the official timing line approximately 10 yards ahead of the start line. This helps prevent burning out your clutch if you were to do a drag race style start. Many autocross classes are won by thousandths of a second, so a good start is very important. Attack the course and do your best to stay within the gates and not knock down any of the pylon cones. The secret to fast autocross times is smooth car control, not sliding around the corners. Then, as suddenly as it started, it's over. When you finish your run, you will be required to come to a complete stop. This is for safety reasons and if you fail to stop you may be disqualified. While you are stopped, you will be handed a timing slip. If you have more runs to take, you should drive slowly to the end of the grid line.

And once again, you will wait a few minutes while your adrenalin is high. I recommend that you get out of your car, take off your helmet and relax. Stay near your car, though, so that you can move it forward in line. Review your last run, and ask someone if you hit any pylons. Think about your strategy for your next run and then do it better next time. You may notice that I said do it better, not faster. Driving better, more smoothly and more efficiently will result in a faster time.

By the way, if two or more drivers are sharing a car, tell the grid workers so that they can stage you in the area reserved for multiple driver cars, which are cycled through the session more quickly. When your session is completed, the results are posted for all the classes in your group.

Trophy Time

After the last car has taken its run, the timing results are verified. Then, the event chairman will call everyone together to award trophies to the top finishers in each class. Whether you place high enough to win a trophy or not, this is a great time for the usual good humor and congratulations that come with a hard day of competition. This is the time for bench racing, when competitors are trying to figure out if a different brand of tires, shocks or sway bars would have made a difference. Or if a different line through the second slalom would have made the difference. Woulda, Coulda, Shoulda! It is grassroots racing at its best!

Final Thoughts

Do not be discouraged if you do not win a trophy at your first few autocrosses. As you gain experience and seat time, you will improve and your times will improve. In addition to Chicago Region's five autocrosses this year, there are many additional opportunities to get the experience you want. Almost every weekend between April and October you can find an autocross event in which to compete somewhere in the Chicago or Milwaukee area. That should tell you how popular autocrossing is. Clubs such as Sports Car Club of America, Tri-State Sports Car Club, Midwest Council, BMW Club and others will welcome you. If you really like this autocross thing, you could be autocrossing every weekend.

Please give autocrossing a try. I hope that you enjoy it as much as I do! Come on out on April 25th.

For additional information contact Jeff Girard at 815.838.3000 or dukiemaxgirard@aol.com

2004 Autocross Schedule

Mark your calendars!

Apr 25 Autocross School* - Maywood

May 23 Autocross I* - Hawthorne

Jun 27 Autocross II* - Rockford

Jul 18 Autocross III - MGA

Aug 22 Autocross IV - Lake Geneva

Sep 19 Autocross V - Maywood

*Event application in this issue of the Chicago Scene

See the 2004 Directory for Autocross and Gymkhana Classes and Notes and Autocross Tech and Safety. The 2004 Chicago Region Tech Inspection Sheet. is in this issue of the Chicago Scene

Required:

- 1990 or newer SNELL SA (special application for auto racing) or M (motorcycle) approved helmet.
- Full shoes. No bare feet, sandals, or open toed shoes.
- 3 point stock seat belt.

Recommended:

- 2000 SNELL SA approved helmet.
- Full-length pants, long sleeved shirts, and socks of non-synthetic materials.
- Driving shoes.
- 4 point (or greater) harness.

Membership News

by Van Miller, 2004 Membership Coordinator, Debby and Ed Leed, Membership Database, and others

March 2004 New Members

Jeff Anderson
Debra Anderson
Grayslake, IL
1985 944 Coupe

Chris Hammond
Lynette Hammond
Hampshire, IL
1995 911 Coupe

Donald Rosenwinkel
Karen Rosenwinkel
Chicago, IL
1973 911T Coupe

John R. Allen
Melissa M. Allen
Barrington, IL
2000 Boxster S

Todd Jackson
Chicago, IL
1976 912E Coupe

Jeff Szidik
Chicago, IL
1999 Boxster

Marcus Babladelis
Kathy Babladelis
Naperville, IL
1988 951 Turbo Coupe

Michael Krick
Niles, IL
1989 928S4

Ariel Trajano
Dante Gruezo
Schaumburg, IL
1987 928S4

Ted Barber
Melissa Barber
Libertyville, IL
1980 911 SC Targa

Kori Kwak
Larry Koscal
Chicago, IL
944 Turbo Coupe

Daniel Urquiza
Sergio Urquiza
Dyer, IN
2003 996 Cup Car

Jordan Block
Masha Veidenbaum
Chicago, IL
2003 Carrera 4 Cab

Scott Martens
Debbie Martens
Crystal Lake, IL
1987 911 Coupe

Robert Zaborowski
John Zaborowski
Northbrook, IL
2002 Carrera 4S

Joseph P Gentile
Samantha Gentile
Libertyville, IL
1998 Boxster

Connie McElroy
Dale McElroy
Champaign, IL
1976 911 Coupe

Transfers

Alan W George
Wilmette, IL
1995 993

Rob Oberwise
Vi Oberwise
Barrington, IL
2001 911 Cab

Jordan Miles
Allison Miles
Chicago, IL
2001 996 C2 Coupe

Jeff Goldman
Jake Goldman
Highland Park, IL
2004 C4 Turbo Cab

Brian O'Connell
Chicago, IL
2003 986

Curt Schilz
Wadsworth, IL
1987 944 S

Philip Guziec
Chicago, IL
1989 930 Coupe

Joe Princis
Susi Princis
Joliet, IL
2004 Cayenne

Welcome! We hope to see you at an event soon.

April Anniversaries

Richard A. Patterson	Linda Patterson	1972	Jason M. Brown	Mary Beth Brown	1997
Larry J. Smith	Sheri Smith	1972	David Ostrom	Rita Ostrom	1998
Chester T. Szerlag	Judy Szerlag	1974	Craig C. Davies		1998
Petr G. Chadraba	Emily Chadraba	1975	Sharif Nijim	Faris Nijim	1998
Richard M. Ward	Bryan R. Ward	1975	Peter Froehlich	David Strong	1998
George Rudawsky	Julie G. Rudawsky	1977	Michael A. Steele	Michael A. Steele Jr	1998
Eric Henderson	Sue Henderson	1978	C. Donald Emery III	Cheri Emery	1998
Richard McCord	Karen L. McCord	1979	K. Wayne Strom	Janis A. Strom	1998
Dennis Hiffman	Barbara J. Hiffman	1982	Paul F. Weiss		1998
Arthur N. Nystrom Jr.	Carol Nystrom	1983	Lawrence A. Gonzalez	Donna F. Gonzalez	1998
Ronald L. Goldstein	Adam Goldstein	1984	Brian E. Hughes	Tim Kautz	1998
Ronald Susser	Suzannah L. Susser	1984	Richard Harris	Martin Harris	1999
Thomas F. Kerrigan	Peg Kerrigan	1984	Deborah M. Martin	Mike Martin	1999
Stephen Kozerowitz	Barbara Kozerowitz	1985	Jeffrey U. Price	Scott Price	1999
John M. Damas	Nancy Ann Damas	1985	James H. Russell	Kay J. Russell	2000
James E. Barzyk		1985	Mario Cairo	Elizabeth Cairo	2000
Russell L. Melton	Berni Melton	1986	William E. Siegfriedt	Corky Siegfriedt	2000
Thomas W. Beihoffer	Denise Boklach Beihoffer	1986	Perry C. Putz		2000
Rob Larson	Ann Larson	1989	Carson G. Greene		2000
Steve Heim	Matt Heim	1989	Jennie Muehl	Kevin Muehl	2000
Louis C. Serpico	Suzanne Serpico	1989	Robert R. Cesario	Tara Cesario	2000
John A. Takehara	Renee Takehara	1989	Morgan Raines	Kristy Raines	2000
Glenn M. Stazak	Mike Bednar	1990	Lawrence Hitchcock	Lawrence Hitchcock	2000
Michael B. Gallagher	Tom Feeley	1990	Maurice L. Breunig		2000
Allen Barrow	Pat Barrow	1991	Andrew M. Szavay	Endre Szavay	2000
John L. Winter	Jonne Winter	1992	Donald Moy	Amanda Wu	2000
Charles E. Reiter III	Catherine C. Reiter	1992	Erick Clark		2000
Gordon R. Roth		1992	Gary L. Lorenz	Shawna Lorenz	2000
Dr. Martin Bour	Joe Bour	1992	Ted Lavizzo	Diretha Lavizzo	2000
Robert A. Habermann	Charlie Habermann	1993	Ronald S. Cushing	Tom Jenkins	2000
Dr. Bruce A. Rohner	Dr. Bruce A. Rohner	1993	Stephen J. Pokorny	Tammy Kohl	2000
Christopher C. Kuehnle	Suzanne Pentak	1993	Charles R. Burnside	Pamela Burnside	2001
Charles Hutchinson	Bonnie Hutchinson	1994	Eric L. Pernod		2001
James Levine	Roger Levine	1994	Paul A. Miller	Cindy Miller	2001
Robert A. Benziger	Marla K. Benziger	1994	Timothy J. Hill		2001
Scott Varwig	Harry Varwig	1994	James Lewan	Kris Lewan	2001
J. Ericson Heyke	Eric Heyke	1994	Daniel J. Santucci	Cari E. Santucci	2001
R. Richard Brown	Donna M. Brown	1994	Joseph M. Scandariato Jr	Joseph M. Scandariato Jr	2001

William G. Elliott	Carol Elliott	2001	Glenn M. Cackovic		2003
Raymond C. VanderHulst Jr	Linda VanderHulst	2001	James L. Schoedinger	James L. Schoedinger	2003
Frank Orlando Jr.	Lisa Orlando	2001	William J. McCarthy	Tricia McCarthy	2003
Anthony T. Chiodo	Karen Chiodo	2001	David R. Rabjohns	Emily Rabjohns	2003
Morgan J. Bullard		2002	Michael D. Best	Amy G. Best	2003
John L. Baranowski	Cheryl Baranowski	2002	Roger G. Angelkorte Jr	Margaret L. Angelkorte	2003
Joseph Lindbloom	Sheri Lindbloom	2002	Robert J. Heniff		2003
Brian Bobbitt	Cherri Bobbitt	2002	JT DeAlcazar	Jessica DeAlcazar	2003
Peter B. Barnes	Francine Barnes	2002	Carlo A. Verissimo		2003
Robert M. Rath		2002	Dennis P. Kamoen	Sheridan Kamoen	2003
Brian P. Anderson	Bill Rice	2002	Martin S. Skjordahl	Bridget Dunn	2003
Scott J. Humphrey	Kathleen Humphrey	2003	Evan J. Lenchner		2003
Ted Eisses	Donna Eisses	2003	Jeff Carroll		2003
Kenneth Dickerson	Michelle Dickerson	2003	James H. Taylor		2003
Paul D. Ing		2003	Bryan R. Mitchell	Mary Mitchell	2003

CHANGE OF ADDRESS

Name(s)

Old Address

NEW ADDRESS

Home Phone

Fax

Work Phone

e-mail

Mail, fax or e-mail to: Debbie Leed, 37 Lakeview Drive, Barrington, IL 60010-1949 / Fax 847.382.3562 (8:00 am - 8:00 pm only) / Leedlast@hotmail.com

Charity Scene

submitted by Jim Drury, 2004 Charity Coordinator

2004 Chicago Region Charity

At the March Board Meeting, the Board selected The Deicke Center for Visual Rehabilitation as the 2004 Chicago Region Charity

The Deicke Center for Visual Rehabilitation and "Seeing Is Believing," a program for children
219 E. Cole Avenue
Wheaton, IL, 60187
Phone (630) 690-7115,
Fax (630) 690-9037,
www.Deicke.org

The Deicke Center for Visual Rehabilitation was established in 1986. Its mission is to provide professional low vision services to persons of all ages who vision cannot be improved medically, surgically or with conventional lenses and provide the tools and training necessary to function in the workplace, at school and in the community. A staff of 14 includes 4 Doctors of Optometry, one Licensed Social Worker, 2 Rehabilitation Teachers with Master's Degrees, and one person certified in Assistive Technology Applications for the Blind and Visually Impaired. The Deicke is nationally accredited.

Children in the Center's "Seeing Is Believing" program are examined in their schools after being identified by Special Education Teachers. One of the Deicke doctors, accompanied by another staff member travels to Illinois schools to give professional "Low Vision Services" to school children. The children are provided with prescription glasses, high powered magnifiers, telescopes and sunglasses free of charge. These prescriptive optical devices enable the children to participate more fully in classroom activities, do homework assignments and travel about the school complex independently. According to outcome reports from the teachers, nearly all of the

children improve academically after receiving services and devices from the Deicke Center.

Many of the children in the "seeing Is Believing" program use computers in their school, but do not have computers at home. Sometimes in school, the computers do not have software that enhances print or gives verbal output. These software programs would make it much easier for the visually impaired children to progress academically. However, they are expensive. In many cases neither the schools nor the families can afford them. The Deicke Center has met some of those needs by holding a Computer Day Camp each year in August to help children review and improve their computer skills.

Although the State of Illinois does give services and optical devices to blind and visually impaired adults over the age of 18, they do not address the needs of children. Computers have leveled the playing field for those who are blind or visually impaired. They do need computers both at home and at

school. They do need computers with enough ram to accommodate the software. They do need benefactors to make those programs available.

A Gauntlet Is Thrown Down

The Chicago Region will again this year participate in the Naperville Exchange Club's 14th Annual Grand Prix (karts). The September 26th event will be a combined Charity/Concours event on the PCA Chicago Region. Calendar.

As if that wasn't enough, to add even more excitement to the event in Naperville, the Exchange Club has challenged several *other* Car Clubs to enter teams in the Grand Prix. The Viper Club has already accepted and thrown the gauntlet down in the direction of our Club. We cannot ignore the challenge!

Please contact Jim Drury (708.354.8121) for more details on how to answer this challenge.

Watch this column for more event details as they are available.



Safety

by Todd Conforti, Safety Coordinator

Safety - Keep Informed

After several years as the Chicago Region's Safety Coordinator there is one thing I can say for sure; the Chicago region does not take safety for granted!

Our club's outstanding safety record is due to the proactive approach we take towards safety. A great deal of time and effort is spent developing safety procedures to reduce the inherent risk found in many of our PCA activities.

Numerous people contribute to these procedures. Many past and present board members, John Ruther, Pete Hackenson, Keith Clark, Chris Ingot, Toby Duckett, Greg Turek, Jim Murray and myself, just to name a few. We also take

suggestions from other regions and PCA National. Frequently a committee is formed to make safety recommendations.

These safety procedures are spelled out in the Membership Directory, can be found in Chicago Scene articles, on line at www.pca-chicago.org, and in particular, in the event packets distributed at all our driving events.

I encourage everyone to read these documents and become familiar with all our safety requirements. If you have any questions or do not thoroughly understand the requirements please get in touch with any one of us. I want to emphasize that now is the time to sit down and really read all this stuff. Then later read as a review

just before an event. Remember, safety is every member's concern!

Having said this, the majority of the safety requirements for 2004 will be the same as 2003. Helmet requirements are minimum 1995 Snell SA for DE and 1990 M or better for autocross. However, if your helmet is over 5 years old it is recommended that it be replaced or at least checked and relined.

In addition, get to know your flags. This year, penalties are being established for not responding to flags properly.

Please feel free to contact me if you have any questions, or if you have any suggestions to make our club safer. I can be reached at 847.952.0070 or tlcontrols@aol.com.

Barrington Coach Haus *Automobile Collision and Restoration Perfection* *Since 1984*

BCH specializes in Porsche, Mercedes Benz, and BMW. We take pride in our workmanship from dings & dents to complete restoration and detailing. All work is guaranteed. Located approximately 7 miles west of Fischer Motors. We will come to you with our Mobile Estimating Unit.

BCH is your one stop body shop!

22073 N. Pepper Road
3 miles west of Route 59 off Route 14
Barrington, Illinois
847-382-5285

Mon - Fri: 8:00 - 4:30
Sat: By Appointment

Contact: Chuck Harley - Owner

Chicago Region Goodie Store

The Goodie Store was open at its second planned event for the year; the February 29th Chili Tasting / Concours School. With Anthony LaMantia's assistance (Chuck LaMantia's 11 year old son), sales were brisk including the sales of previous seasons items at discounted prices. The deal of the day was the region hat available from last season now selling at \$15.00. New items drawing the most interest are the long sleeve denim and the black half zip fleece jacket. Inventory has been replenished on both items in order to meet what is expected to be great interest at upcoming events. Continuing on with the success from the General Membership Meeting, sales have now reached the 40% level of the initial apparel order for this season.

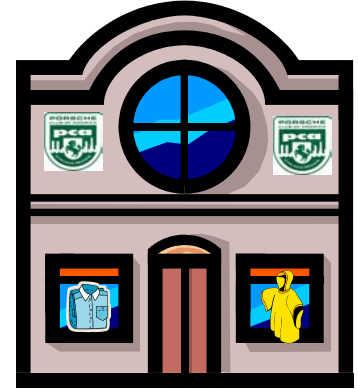

Available at this time are the following items:

Long sleeve button down denim shirts	\$30.00
Long sleeve button down white shirts	\$35.00
Fleece jacket - Half Zip - Black	\$33.00
Fleece jacket - Full Zip - Gray	\$35.00
Waterproof rain gear (Jacket and pants)	\$87.00

All of the above items (with the exception of the rain pants) have the Chicago Region Logo on the front. In addition, with the exception of the rain gear, a large or small Club Racing logo may be added on the back. The small Club Racing logo adds \$8.00 and the large Club Racing logo adds \$20.00.

The goal of the goodie store is to break even. The only exception may be the rain gear! Given the unusually high number of wet track days last season, special excise taxes may be added while the rain is falling. So, purchase early!!

Items being contemplated for the warming weather include sleeveless shirts for the ladies and a couple of apparel items for the kids. Please continue with offering your suggestions. If we do not have a particular size or style, we can always place an order as we have no minimum order restrictions.

The Goodie Store is planning on attending the following upcoming events:

Please remember to bring extra cash or checks to the events as we are not yet set up to handle credit card payments. Stay tuned to the Scene and Chicago Region web page for additional information

April 25th Autocross School

May 5th Blackhawk DE Experienced

May 12th Blackhawk DE Novice

New items will be highlighted in the Chicago Scene and on the Chicago Region web page.

Chuck LaMantia & Keith Clark
630.510.7418 or claman1022@msn.com 630.690.3381 or ClarkFNFlying@aol.com

Chili, Concours, & Hot Wheels

by Russ Pesko

It was one of the best Sundays so far this year weather-wise, and despite it being a nice day to take the Porsche out for a long drive, we had a good turn out for the annual Concours school and Chili tasting, held this year at Joe Rizza Porsche in Orland Park.

An estimated 75-100 people showed up to taste the many fine variations of chili, and learn the basics as well as finer points of car care while the kids enjoyed racing remote control and Hot Wheels cars.

Pat Yanahan, our resident Concours expert, put on another excellent class on car care products and their correct uses. He started with a lecture on the various commercially available items, how to use, (as well as how not to use) them effectively.

A question and answer session was next. While there was as usual, a live demonstration of paint chip repair, this year, using a car

provided by A.J. Tiller, there was an actual hands-on practice session, which turned out to be an excellent learning tool. As one participant told me, "It's one thing to watch and listen, but when you actually try it, and see what you're doing right and doing wrong, it makes it whole lot more comfortable for me to work on my own car. Now I'm not so nervous about damaging the finish on my car- something that kept me from doing this before".

Also lending a hand was Rick Anstadt, who runs Body Skins, a paint protection company that sells and installs the clear plastic coating that takes the place of an automotive bra to protect from chipping.

The kids had fun with the RC cars, and there were races with Hot Wheels cars on a new one-piece track provided by Jim Jacisin. Everyone is a winner of course, and all went home with Hot Wheels cars in addition to the very nice prizes.

Having more room than in the past couple of years allowed us to have ample space to set up several tables featuring 6 categories of chili, plus bowls of add-ons which included chives, cheddar cheese, sour cream, oyster crackers and tortilla chips. We had plenty of power cords and outlets to keep everyone's crock pots going, and for (I think) the first time, not a single blown fuse!

There were over 20 chili cooks providing chili this year, with slightly different categories than last year.

Special thanks to AJ Tiller and Van Larson who put a lot of work into organizing and running the event, the volunteers who helped setting up tables and dishing out the trimmings (special mention to the hand chopped chives), and to Pat Yanahan for his continuing excellent job teaching club members the fine art of caring for the exteriors and interiors of everyone's favorite car.

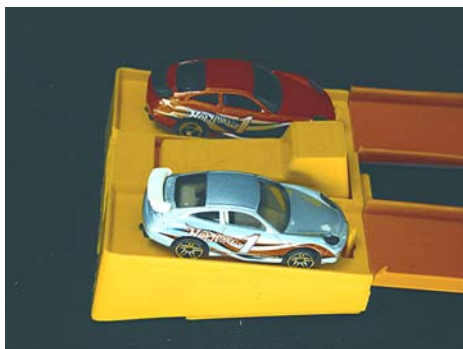

(top) GT3 vs GT3
(bottom) 917 vs GT1

photos by Jim Jacisin

Hot Wheels Car Races

1st Place:

Kristen Doherty - Porsche 911 GT1

2nd Place:

Anthony Lamantia - Porsche 911 GT1

3rd Place:

Nicole Ingot - Super Modified

The Field:

Ashlynn Diwik
Andrew Gallagher
Monica Ingot
Kristen Ingot
Adam Ostrowski
Mark Ostrowski
Mike Ross
Taylor Sadkowski
Emily Wardell
Joey Wardell



Competitors choose your cars!

photo by Russ Pesko

Chili ...

Meatiest-

- 1st Amber Costello
- 2nd John Diwik
- 3rd Bonnie Yanahan

Beaniest

- 1st Sue Markese,
- 2nd Mary Ann Nowakowski
- 3rd Tom Thompson

Hottest

Van Larson

Wickedest

- 1st Russ Pesko
- 2nd Rachel Reed

Vegetarian

- 1st April Millhouse
- 2nd AJ Tiller

Overall

- 1st Dan Gallagher
- 2nd Debbie Aver

Edible Art

Nick Brenkus



The Winning Chefs

photo by Claude Reed



Enjoying the chili and each other's company



(top right) Dig in!



(right) The Sadlowskis

photos by Steve Rashbaum



Pat Yanahan discusses helpful products and tools for concours preparation



Rick Anstadt from Body Skins



A J Tiller (left) and Van Larson, Concours Coorindators

photos by Russ Pesko

Chuck LaMantia (facing camera) 'mans' the Goodie Store

photos by Steve Rashbaum



(below right and left) Eye candy in the Rizza Porsche Showroom



Q-tip Corner: Concours Scene

Chip and Tale: Part I

by Van Larson

For those of you who were unfortunate enough to miss Pat "da Man" Yanahan's magic stone chip repair technique demonstration at this year's "Chili Tasting/Concours School/etc.", held February 29th at Rizza Porsche, your humble servant finally succeeded in getting Pat to put together a written description of his almost greatest claim to fame. Pat, however, advises that you practice, practice, practice on an "experimental" vehicle (Yugo, Trabant, Vega, Pinto, etc.) before applying this to your prized Porker, for obvious reasons. Pat reports that a Mercedes door mercifully donated itself as his first victim - both the door and he survived.

Pat breaks his magic act down into two major steps: the preparation of the surface and painting and the sanding and finishing.

Be safe and do this in a well ventilated area. Use eye protection as this will involve "close, up-

front" work - no hospital trips are necessary as part of his process.

Step one: Prepare the surface by removing all wax from the chip area - household dish soap and then a commercial wax remover. Pat uses a PPG product called "Acryli-Clean Wax and Grease Remover DX330, usually available at a good hardware store. Follow the can's directions. Pat uses a fluorescent trouble light to scan the paint surface to identify the chipped areas, then places a small piece of masking tape next to the chip and draws an arrow on the tape to point to the chip (helps to later locate the repaired chip area, hopefully).

Next, to get the paint to adhere, the "valley" of the chip (not dolls) must be cleaned out - no dirt or rust allowed. Pat uses toothpicks with a round pointed end and old, used dental tools - he does have his ways, doesn't he! (See #1) Make nice with your DDS at your next visit and ask him/her to save the broken picks for you - maybe you'll get some free laughing gas as a pain deadener.

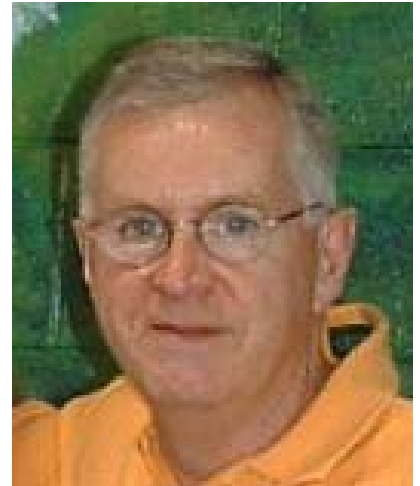

Pat "da Man" Yanahan

photo by Russ Pesko

Once you get down to a clean bottom of the chip (primer or bare metal, depending on impact results), again use the wax and grease remover to clean out all dislodged junk and dust so that you have a clean surface that has small microscopic edges for the new paint to grab onto. What you want is a nice valley as shown in the BEFORE illustration. (See #2)



Even more reasons to visit your Dentist on a regular basis

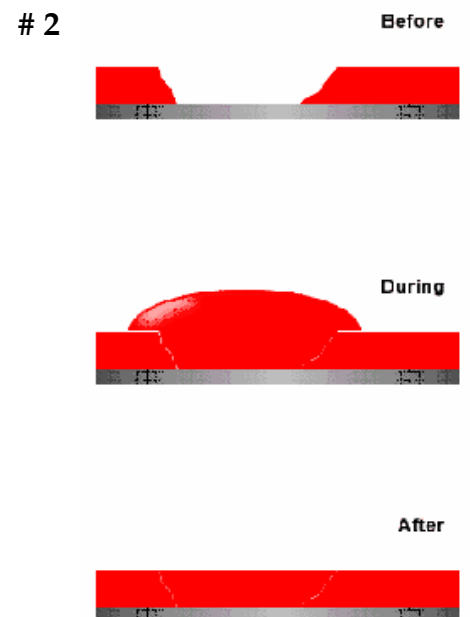

Illustrations courtesy of Pat Yanahan

Now, the paint - APPLY SPARINGLY - PATIENCE WILL HAVE ITS JUST REWARDS. Two to four tiny applications of paint versus one big glob is how to proceed. You DO NOT want the big glob as shown (See #2) in the DURING part of the illustration. This is the mistake most beginners make.

Try to let the paint dry between applications (have a beer, watch the first half of LeMans for the 63rd time) since you don't want big mountains of paint to sand down and adversely affect the surrounding undamaged area.

Tool time: paint, small pointed end toothpicks or EX applicators. PaintScratch.com is a good source for about any vehicle touch up paint - supply the factory paint number from your Cardex. Number, not name of color as the formulas may change even though the name stays the same. If you have faded paint and you really want a perfect match, take off your gas filler lid and take to a professional auto paint supplier for a custom color match.

BTW, Pat advises not to use the brush typically found on the screw head of touch up paint bottles -

applies much to much paint and is too big an applicator. Start with a pointed tooth pick or the EZ applicator which has a microscopic sponge on the end of the plastic stick (Griot's garage sells em, too.).

Four hours after the first small dab - remember, a little dab will do ya. Pat usually rests up for a couple of days between each layer is Applied - told you he was a patient guy.

Since age has the tendency to lessen one's visual acuity, work in a bright lighted are - this will help you see when you try to build up the paint in stages so you have a small "dome" to the cross-section of the valley of the chip. Make sure your paint is dry (at least overnight) because now the fear and the fun begins - SANDING AND POLISHING to get to the flat AFTER surface that will make your baby shine.

Be sure to stay tuned for next month's exciting conclusion. I hope Pat gets enough rest in the meantime because I sure don't know what to do or how to end this story!

For more Concours information, please contact:

Van Larson
630.377.4686
Valyr9090@aol.com

A J Tiller
312.735.8771
aj2manycars@aol.com

Pat Yanahan has volunteered to answer Concours related questions. Questions may be submitted to ChiScene@aol.com and I will pass them along to Pat and print the question and answer.

2004 Concours Schedule

- I Jun 13th - Medinah CC*
- II Jul 25th - Potter's Picnic
- III Aug 1st - Cuneo Museum
- IV Sep 4th - TRAC 2004/
Elkhart Lake, WI
- V Sep 26th - Naperville Grand Prix

*Event Announcements in this issue of the Chicago Scene

Index of Advertisers

914 Limited ----- 14	Kelly Moss Motorsports ----- 10
American Collectors Insurance, Inc --- 40	Manny's----- 5
Autobahn Country Club ----- 58	Midwest Eurosport ----- 4
R A Adams Enterprises----- 52	Midwest Performance Cars----- 40
Bacino's----- BC	MPH Technologies, Inc ----- 52
Barrington Coach Haus----- 21	Napleton Porsche ----- IBC
Body Werks of Barrington ----- 29	Northstar Motorsports ----- IFC
Century 21 Advisors, Inc----- 29	O'Hare Autobody ----- 32
The Exchange ----- 62	PressTech----- 30
Fischer Motors ----- 55	R & W Performance----- 33
Fischer Motors Test & Tune ----- 11	Joe Rizza Porsche----- 34
Forest Engraving ----- 68	



PCA CHICAGO REGION 2004 DRIVERS' EDUCATION EVENTS

Drivers' Education is a medium to high speed (top speeds can be from 90-130 mph) event on a closed course (race track). Multiple cars are on the track simultaneously with tightly controlled passing rules. No racing is tolerated. This is not a timed event, and there is no competition. Both classroom and in-car instruction, utilizing approved PCA Instructors, are an integral part of these events. Skills practiced include choosing the optimal path around a road course, controlling a vehicle at its cornering limits, slowing a vehicle, and utilizing controlled situations to improve understanding of vehicle dynamics. Please check the latest issue of "Chicago Scene" for event locations and starting times.

CHICAGO REGION DRIVERS' EDUCATION VENUES

Blackhawk Farms Raceway: 1.8 mile road course with 7 turns, located in South Beloit, IL

Gingerman Raceway: 1.88 mile road course with 11 turns, located in South Haven, MI

Road America: 4 mile road course with 14 turns, located in Elkhart Lake, WI

DRIVERS' EDUCATION 2004 EVENT SCHEDULE

- | | |
|---|--|
| ✓ Wednesday, May 5 | Blackhawk Drivers' ED, Experience Drivers' |
| ✓ Wednesday, May 12 | Blackhawk Drivers' ED, Novice/Instructors Only |
| ✓ Friday, May 28 | Road America Drivers' ED, Novice Instruction |
| ✓ Saturday, May 29 & Sunday, May 30 | Road America Drivers' ED, Memorial Weekend |
| ✓ Friday, June 11 | Blackhawk Drivers' ED |
| ✓ Friday, July 23 | Blackhawk Drivers' ED |
| ✓ Saturday, August 7 & Sunday, August 8 | Gingerman Raceway Drivers' ED |
| ✓ Wednesday, August 18 | Blackhawk Drivers' ED |
| ✓ Friday, Sept. 3 thru Monday, Sept. 6 | Road America Drivers' ED Labor Day Weekend |
| ✓ Wednesday, September 15 | Blackhawk Drivers' ED |
| ✓ Saturday, October 2 & Sunday, October 3 | Blackhawk Octoberfest Drivers' ED |

DRIVERS' EDUCATION EQUIPMENT REQUIREMENTS

REQUIRED:

- ✓ 1995, or later, SNELL SA approved helmet. (No M rated Motorcycle Helmets)
- ✓ Full length pants, long-sleeved shirt, and socks of non-synthetic materials
- ✓ Full shoes. No bare feet, sandals, open toed or thick-soled shoes
- ✓ Original factory installed belts for Novice, C & B2 run groups
- ✓ 6 point harness system with stock seat (H strap without harness bar) – or – race seat and 5 or 6 point harness system for all other classes and Class B at Road America
- ✓ Harness and seats must be similarly equipped for driver and instructor side
- ✓ Refer to 2004 Tech Inspection Sheet for additional information and requirements

RECOMMENDED:

- ✓ Competition brake pads and fluid
- ✓ Driving suits, driving shoes, neck collar, and gloves made of fire resistant materials
- ✓ Fire extinguisher

RECOMMENDED FOR MORE ADVANCED DRIVERS/FASTER CARS:

- ✓ Roll bar or roll cage
- ✓ DOT approved race tires (e.g. Hoosier or G Force)

The Straight Scoop: DE Scene

by John Ruther, 2004 Chicago Region Chief Driving Instructor

New DE Passing Rules

Since we are nearing the beginning of the Drivers Education season I want to talk a little about a change that was made last season. We have changed the passing rules for our DE events. Previously, and for as long as I can remember, we only allowed passing on the left. This was irrespective of race track and also irrespective of whether the next turn was a left or a right.

The biggest problem with passing only on the left is that most of our tracks in this country are predominantly clockwise rotation, which means that there are many more right hand turns than lefts. Take Road America for example, depending on how you count, there are 9 Rights and 4 Lefts. I know Road America has 14 turns not 13, ... well, Station 4 is not a turn. What that means is the car doing the passing is staying on-line for all the right hand turns while the car being passed is moving off-line for the right hand turns, and the opposite for left hand turns.

The assumption here is that many passes occur toward the end of the straight just before the brake markers. This process of having the car being passed moving over so the car doing the passing can get by is completely counter to what is experienced in actual wheel-to-wheel racing. Aside from the fact that no one is simply going to move over so you can pass, the car doing the passing is always going to have to pass Off-Line, simply because the car being passed isn't going to make it easy for you. Since one of the purposes of Drivers Education is to, in many cases, prepare a driver to ultimately go club racing, starting in the beginning with passing rules that are very similar to what will be experienced in a racing environment seems a good idea.

Therefore, the new DE passing rules are for the car doing the passing to pull off-line and to pass off-line. That means that you will be passing on the left coming into a left hand corner and on the right just before a right hand corner. Our DE rules have always required that the car being passed point out the window in a definitive motion for each car to pass. Under the new rules, the point will now be straight out for a pass on the left, and arm up over the top of the car for a pass on the right.

In the beginning this sounds somewhat confusing, but once you get used to it, it is much more natural

than arbitrarily forcing the pass to always be done on the left, probably because that's how we pass on the street. Having said all of this, the one thing this new rule requires is that the car being passed MUST know where the line is and to stay on the line and to point the faster car by on the off-line side, just like in real racing.

The other reason for this rule change is that it is soon to become the new national standard. So when you travel to different regions to do DE events, and many of our members do, the passing rules will be the same no matter where you go.

DESI VINCZEN
BOB VINCZEN

Body Works of Barrington
SPECIALIZING IN MERCEDES, PORSCHE AND B.M.W.
ALL IMPORTED SPORTS CARS

126 N. COOK STREET
BARRINGTON, ILLINOIS 60010

PH 847.381.9144
FAX 847.381.9163

Century 21
Advisors, Inc.

1816 S. Arlington Heights Rd.
Arlington Heights, Illinois 60005
Office (847) 952-0909
Fax (847) 952-0961
Cellular (312) 404-9965
E-Mail newhome4u@comcast.net
Website www.advisorsrealty.com

Each Office is Independently Owned And Operated

Peter Sygieda
REALTOR®





INK

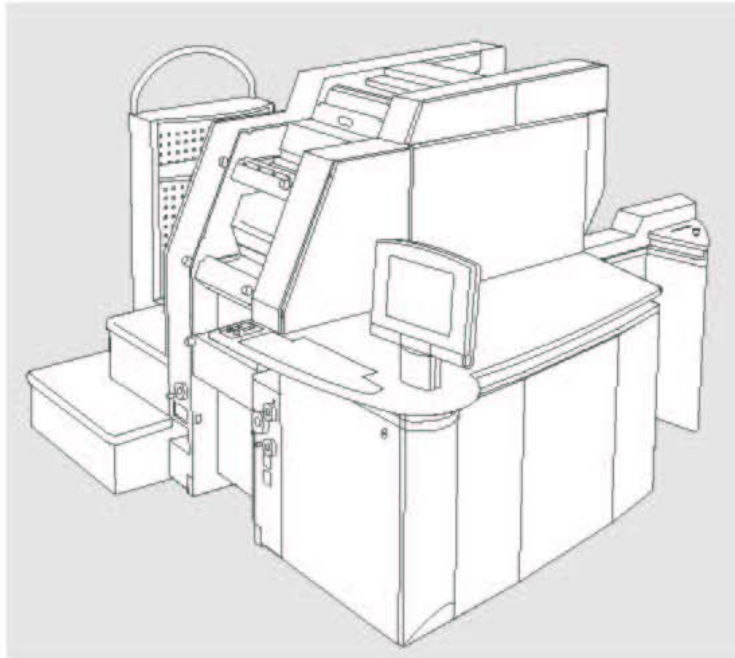

Offering the latest printing technology and experienced press technicians, we are determined to provide the best possible product – every time. This commitment to quality extends beyond paper and press to include regular reviews of the latest in ink and color technologies. At the core of any printing specification is the often overlooked ink quality and sequence. To maintain a standard of excellence, we consistently calibrate our presses to match the latest advances in inks and toners. Be it spot color, dry-trapped varnishes or 4-color process, our careful attention to detail ensures your job will stand out.

THE HEIDELBERG D1 Registration on the Heidelberg D1 is among the tightest of any commercial press available. This level of quality is achieved through a single gripper system that ushers each sheet through the different rollers without ever changing handlers. Direct-to-plate prepress, the tightest possible registration and the ability to print with your choice of inks are all part of our commitment to delivering the best possible product.



PRESSTECH
INK. PAPER. PRIDE.

959 Lee Street • Des Plaines, Illinois 60016

P 847.824.4485 F 847.824.4775



Blackhawk Experienced Drivers' Education

Wednesday, May 5th

MOTORSPORTS

Here it is, the first track event of the year. As you know, Blackhawk is a great road course close to home in Rockton, Illinois. **This May 5th event is for Experienced Blackhawk drivers only.** Since most Blackhawk events are sell-outs, pre-register as early as possible to assure a spot. Waiting lists will be used to fill any open spots. Cancellations & refunds will be honored until 9 p.m. on the Monday prior to the event.

Mandatory clothing for all drivers at this event includes: a Snell SA 1995 or 2000 Helmet, long sleeve cotton shirt, long pants, socks, all made of non-synthetic materials, and closed toe shoes.

Recommended but not mandatory are: driver's suit, driving gloves, driver shoes and a protective neck brace all made of Nomex or similar fire-resistant material, as well as a mounted fire extinguisher. Please check the date on your helmet now, as it will be inspected during the Tech Inspection at the track. **If you and your car do not pass Tech Inspection, you will not be able to drive.** You will be required to show a valid drivers license (no tickets accepted) along with a current and valid PCA Membership at registration.

You can save time at the track by bringing your car to a recognized Porsche Dealer or Porsche Specialty Shop for mechanical inspection and having them complete, sign and stamp the Chicago Region Tech Inspection Sheet. Review the NEW Updated Year 2004 Tech and Safety Requirements – there are changes from the prior year! Pay particular attention to specifics concerning brake pads and fluid, since Blackhawk Farms is very hard on the brake system!

Blackhawk Concession Stand serves breakfast from 9 a.m. until 10 a.m., lunch from 10 a.m. until 1:30 p.m. The Accessories Store has gas (leaded & unleaded Race only), air, and showers that are open all day.

General Event Schedule:

- 8:00 a.m. - Registration & Tech Open
- 9:00 a.m. - Mandatory Drivers' Meeting
- 4:30 p.m. - Last Car off Track

Contact Event Chairman:

Pete Hackenson (630) 655-4661
p.hackenson@comcast.net

Directions From Chicago: Take I-90 west to the Rockton Road exit (about 15 miles north of Rockford.) Go west (left turn) on Rockton Road, approximately 5.5 miles and through town of Rockton to Prairie Avenue. Go north (right turn) on Prairie Avenue, approximately 1.5 miles to the track, which will be on your left.

* Mobil station 2 blocks south of Rockton Rd. on Blackhawk Blvd.

First Driver

Year/Car Make/ Model/ Permanent Car Number _____

Phone _____

E-mail _____

(circle ALL applicable) Member Non-Member Guest of: _____

Run Group:

[Instr/Red] [A/Black] [B1/White] [B2/Yellow] [C/Green]

Prior Experience: _____

Second Driver (same car)

Phone _____

E-mail _____

(circle ALL applicable) Member Non-Member Guest of: _____

Run Group:

[Instr/Red] [A/Black] [B1/White] [B2/Yellow] [C/Green]

Prior Experience: _____

Pre-registered Entrance Fees received by May 10, 2004:

Member First Driver - \$170	\$ _____
Family Member-2nd Driver - \$100 *	\$ _____
Non-Member - \$170	\$ _____
Registration received after May 3rd, or On site registration add \$10	\$ _____
Total	\$ _____

* The \$100 fee only applies to 2nd family member who drives the same car as the first driver.

Make check payable to: PCA- Chicago Region

Mail to: Todd Conforti - Blackhawk Drivers' ED Registrar
553 West Carboy Road
Mount Prospect, IL 60056
(847) 382-9656 home (847) 952-0070 work
e-mail: tlcontrols@aol.com

For more information on Track Events, Schedules, Tech & Safety Requirements use the WEB at WWW.PCA-Chicago.org
For more Blackhawk information go to
WWW.namotorsports.com/Tracks/Blackhawk.html.



O'HARE

auto body

The finest in auto body repair from street to full race, aero kits to custom body design, and detail work to complete paint jobs. We have superior equipment and an expert team dedicated to customer service for the distinguished auto enthusiast.

**Celette Dedicated
Fixture Bench**

**Pro Spot Resistance
Spot Welding**

Full Lifetime Warranty

**Expert Insurance
Claim Processing**

**Onsite Towing and
Rental Service**

**Certified Automotive
Restoration Technicians**

I-Car Certified

Glasurit Authorized Refinisher



**O'Hare Auto Body Ltd.
1316 W. Irving Park Road
Bensenville, IL 60106
Ph: (630) 766-6668
Fx: (630) 766-6663**

Q & A

How To Avoid Speeding Tickets: Part IV

Dan Metz, Potpourri, July 02

In the Fourth Installment in *Driving Safely While Avoiding Speeding Tickets*, we'll see what steps you should take to defend yourself.

By now, you've been stopped, issued a citation, pled Not Guilty, asked for a Trial by Jury and issued subpoenas requesting evidence. The next step is up to the (probably Assistant) State's Attorney. The State's Attorney would like to avoid a Trial by Jury. (S)he knows that the cost of the Trial will be many times that of any fine received, even including court costs.

Typically, a few days before the Trial is scheduled to proceed, you will receive a telephone call from the State's Attorney, with an offer of plea bargaining. As you ponder this offer (which often takes the form of an "equipment violation" having a higher fine than the speeding citation but with the bonus of *no points on your driving record*), keep in mind that the *real cost* of a speeding citation and points on your record is *many times* the cost of the ticket in the form of increased insurance premiums. Thus, it may very well be worth your while to accept this offer, even if the up-front costs are greater than the citation amount.

Do *not* agree to any plea bargain that involves points against your driving license, however. If that is the best that is offered, you should plan to slug it out in open Court.

Your first line of defense is to discover any errors in the State's case. For example, is the date on the citation correct? Has the radar gun been properly calibrated? Can you verify the location? Were there any inconsistencies between what you're charged with and what the actual statutes say? This is why your

subpoenas are so important: they enable you to discover such inconsistencies in advance of the trial itself.

In some jurisdictions, the date on your ticket is the date on which you will be *arraigned*. On that date, when you go to Court you'll be advised of your rights and asked to enter a plea (of "Not Guilty," of course!). You can then almost always get a Continuance, because you are entitled to have time to prepare a proper defense. In other jurisdictions, the Arraignment and Trial occur on the *same day*. Be sure you understand which by phoning the State's Attorney's office ahead of time. Best policy is to be ready for anything.

When you plead "Not Guilty," be sure to resist any "helpful suggestions" by either the Judge or State's Attorney. Simply answer all such suggestions with "I want to

see the State's case before I decide to do anything.

"Should you take the stand? If you're cool under pressure and can stand cross-examination, it is a good idea. A Jury will be curious about you and your side of things. On the other hand, remember that you have to answer questions truthfully or you are guilty of perjury.

You get to examine the prospective Jurors (this is called *voir dire*), and you should ask each one if they understand that you are innocent unless the Prosecution proves each element of the charge beyond a reasonable doubt, if they would agree that radar can malfunction under certain circumstances, and that Police Officers can make mistakes.

Next month, we'll do the Trial itself, and fill in the blanks about what you can expect from it.

RW & LW
PERFORMANCE
PARTS-ACCESSORIES-TOOLS

Full line of performance parts, OEM parts, and tools for Porsche. Shop our growing online catalog. If your part isn't online yet, contact us for availability and pricing. We specialize in providing low prices for your entire project list - send a list for your quote.

RWPARTS.COM

PERFORMANCE FRICTION BRAKES

2615 Rutland Rd.,
Naperville, IL 60564
630-841-2959

Joe Rizza Porsche



THE FASTEST GROWING IN THE U.S.A.

IN STOCK / IN-BOUND PORSCHEs

- 2004 911 Cabrio - Tip Speed Yellow/Black!
- 2004 GT3s 2 To Choose!
- 2004 911 C4S - Tip Black/Black!
- 2004 C4S Cabrio - "6spd" Artic Silver/Black!
- 2004 C2 Cabrio - "Tip" Carmon Red/Savanna!
- 2004 C4S Coupe - "6spd" Guards Red/Black!
- 2004 C2 Coupe - "Aero" Midnight Blue/Graphite!
- 2004 C4S - 6spd Seal Grey/Black!
- 2004 911 Turbo - 6spd Artic Silver/Black!
- 2003 911 - 6spd Black/Black!
- 2003 Boxster - Tip Dark Teal/Graphite!
- 2003 Boxster "S" - 6spd Midnight Blue/Graphite!

CALL FOR UPDATED PRE-DRIVEN INVENTORY

- '03 Boxster Tiptronic - 8K Miles 2 To Choose!
- '03 Boxster 5spd - 6K Miles \$38,900
- '02 Targa 6spd - 2K Miles \$68,900
- '02 911 Cabrio - 6K Miles \$64,900
- '02 Targa 6spd - 10K Miles \$64,900
- '02 911 Coupe - 16K Miles \$58,900
- '01 911 Coupe 6spd - 9K Miles \$52,900
- '01 Boxster "S" - 19K Miles - Aerokit \$38,900
- '01 Boxster - 9K Miles \$31,900
- '00 911 C4 Coupe 6spd - 37K Miles \$45,900
- '00 Boxster 5spd - 14K Miles \$29,900
- '99 Boxster 5spd - 19K Miles \$26,900
- '97 911 C4S - 28K Miles \$51,900
- '97 Boxster 5spd - 57K Miles \$19,900
- '96 911 C2 Coupe - 21K Miles \$40,900
- '95 911 C4 Coupe 6spd - 53K Miles \$38,900
- '87 928 S4 Automatic - 56K Miles \$17,900

7th Annual Porsche Clinic

**SATURDAY, APRIL 24TH
8AM - 3PM**

- Free Service Inspection
- Complimentary Gifts
- Lunch For All Who Attend

Please RSVP With The Service Department

**For All
Porsche
Club
Members...**



JOE RIZZA

PORSCHE

ING PORSCHE DEALER



0% OFF!

ALL PARTS & LABOR!

EXCLUDES SCHEDULED MAINTENANCE

SPECIAL DISCOUNTED RATES ON ALL SCHEDULED MAINTENANCE!

A



159th Street & 80th Avenue
ORLAND PARK

708 403-0300

SHOWROOM HOURS: Daily 9-9:30 & Saturday 9-7:30



www.rizzacars.com

March Word Find Solution

AFTER
BEFORE
CAST
CHECKPOINT
CORRECTION FACTOR
CROSSROAD
DOES NOT EXIST
DRIVER
FREE ZONE
GENERAL INSTRUCTIONS

INTERSECTION
IN TIME
LEFT AT Y-T
MAIN ROAD RULE
MILEAGE
NAVIGATOR
ONTO
OUT MARKER
OUT TIME
PAUSE

RALLYMASTER
REDUNDANCY
RIGHT AT Y-T
ROUTE INSTRUCTIONS
SEAT OF PANTS
SIDE ROAD
SPECIAL INSTRUCTIONS
STRAIGHT AS POSSIBLE
SUPPLEMENTAL INSTRUCTIONS
TRANSIT ZONE

T	P	N	M	U	G	S	T	R	A	I	G	H	T	A	S	P	O	S	S	I	B	L	E	Q	O	C	M	M	T
R	Y	S	B	A	Y	N	C	L	N	N	B	C	K	C	R	G	K	J	A	M	E	K	E	V	R	E	M	X	
L	W	A	P	E	N	O	Z	T	I	S	N	A	R	T	F	Y	V	Z	J	A	D	K	P	I	T	Q	K	G	R
O	J	V	K	R	H	I	Y	U	W	A	Y	P	M	G	W	O	J	X	R	I	K	L	T	V	W	S	H	E	T
A	B	D	P	D	Z	T	I	C	Z	L	C	R	U	C	S	Z	O	W	A	L	L	B	O	T	X	Q	F	Q	Z
X	A	B	G	Z	U	C	M	F	W	G	F	Z	V	Q	A	F	S	M	Z	M	P	G	O	R	C	M	C	I	E
S	N	O	I	T	C	U	R	T	S	N	I	L	A	T	N	E	M	E	L	P	P	U	S	G	S	D	J	I	Q
A	S	A	S	T	C	R	K	I	C	Y	C	N	Y	P	V	F	N	K	O	B	A	T	O	A	X	B	N	Y	R
O	H	P	Y	T	G	T	I	G	L	W	A	W	E	I	Y	R	W	Q	V	E	T	S	O	L	Z	K	U	Z	E
W	V	V	Q	R	I	S	H	T	I	A	O	F	C	A	S	T	C	Q	Q	Y	U	O	M	D	G	Z	T	I	J
R	B	T	Q	N	S	N	F	T	N	M	F	T	R	G	V	C	N	W	V	P	M	G	P	J	T	K	F	C	Z
I	W	S	G	J	J	I	G	R	T	I	O	T	N	E	R	D	D	C	T	M	A	B	K	G	J	S	Z	M	Q
T	R	N	Y	N	J	L	D	B	E	F	O	R	E	O	E	R	X	U	G	I	X	U	A	E	E	I	N	E	O
Y	D	Z	G	R	X	A	M	E	A	F	L	P	S	R	I	Z	H	P	M	L	X	E	S	N	K	V	C	H	G
D	T	M	M	D	D	I	A	B	R	B	R	S	K	V	P	B	O	V	R	E	H	T	F	E	G	J	F	Q	M
A	A	L	T	X	A	C	C	F	C	O	R	R	E	C	T	I	O	N	F	A	C	T	O	R	F	W	O	H	K
S	Z	R	Y	C	N	E	J	H	O	O	A	R	R	L	E	L	I	P	E	G	K	Q	X	A	R	E	L	Y	Z
C	Y	W	P	Q	E	P	T	W	A	N	F	D	B	A	E	H	Y	N	I	E	U	U	M	L	W	V	G	W	Q
P	N	U	P	O	B	S	Y	D	J	I	R	K	L	F	C	F	C	N	T	I	Y	I	A	I	Z	D	V	E	U
P	W	O	H	O	S	R	D	T	T	H	D	O	E	S	N	O	T	E	X	I	S	T	I	N	K	V	Y	R	C
X	N	B	H	Q	E	Q	J	Y	E	M	I	T	T	U	O	E	Z	A	V	Y	M	P	N	S	P	N	H	R	S
X	W	A	A	D	A	Z	F	T	J	O	U	T	M	A	R	K	E	R	T	S	W	E	R	T	V	F	E	A	V
S	Q	E	C	J	T	J	R	A	N	E	U	P	O	S	G	D	D	Z	K	Y	J	E	O	R	K	D	Q	P	D
L	Z	F	F	O	O	D	Y	T	J	C	W	I	E	P	M	I	G	L	F	R	T	O	A	U	C	U	M	U	M
C	M	M	P	C	F	P	H	H	O	U	P	C	H	S	E	S	V	Q	T	K	D	N	D	C	H	Z	S	H	J
D	Z	B	W	P	P	V	N	G	Q	O	T	O	G	M	P	R	R	A	J	V	S	Q	R	T	Q	E	C	X	R
D	J	X	E	H	A	T	Z	I	F	I	Z	I	O	A	V	A	J	U	N	C	T	F	U	I	Y	B	J	A	M
L	T	I	R	K	N	Y	Y	R	O	R	E	T	S	A	M	E	Y	L	L	A	R	T	L	O	W	M	X	X	V
L	F	Z	X	P	T	L	C	N	R	E	D	U	N	D	A	N	C	Y	Q	L	Q	G	E	N	K	C	X	N	A
J	G	L	X	M	S	N	O	I	T	C	U	R	T	S	N	I	E	T	U	O	R	J	B	S	J	O	E	B	Y



Blackhawk NOVICE Drivers' Education

Wednesday, May 12th

PCA-CHICAGO

Here it is, the first track event of the year. As you know, Blackhawk is a great road course close to home in Rockton, Illinois. **This May 12th event is for Novice Drivers and Instructors only.** Since most Blackhawk events are sell-outs, pre-register as early as possible to assure a spot. Waiting lists will be used to fill any open spots. Cancellations & refunds will be honored until 9 p.m. on the Monday prior to the event.

Mandatory clothing for all drivers at this event includes: a Snell SA 1995 or 2000 Helmet, long sleeve cotton shirt, long pants, socks, all made of non-synthetic materials, and closed toe shoes.

Recommended but not mandatory are: driver's suit, driving gloves, driver shoes and a protective neck brace all made of Nomex or similar fire-resistant material, as well as a mounted fire extinguisher. Please check the date on your helmet now, as it will be inspected during the Tech Inspection at the track. **If you and your car do not pass Tech Inspection, you will not be able to drive.** You will be required to show a valid drivers license (no tickets accepted) along with a current and valid PCA Membership at registration.

You can save time at the track by bringing your car to a recognized Porsche Dealer or Porsche Specialty Shop for mechanical inspection and having them complete, sign and stamp the Chicago Region Tech Inspection Sheet. Review the NEW Updated Year 2004 Tech and Safety Requirements – there are changes from the prior year! Pay particular attention to specifics concerning brake pads and fluid, since Blackhawk Farms is very hard on the brake system!

Blackhawk Concession Stand serves breakfast from 9 a.m. until 10 a.m., lunch from 10 a.m. until 1:30 p.m. The Accessories Store has gas (leaded & unleaded Race only), air, and showers that are open all day.

General Event Schedule:

8:00 a.m. - Registration & Tech Open
9:00 a.m. - Mandatory Drivers' Meeting
4:30 p.m. - Last Car off Track

Contact Event Chairman:

Dan Gallagher (708) 784-0784
Bbabies@aol.com

Directions From Chicago: Take I-90 west to the Rockton Road exit (about 15 miles north of Rockford.) Go west (left turn) on Rockton Road, approximately 5.5 miles and through town of Rockton to Prairie Avenue. Go north (right turn) on Prairie Avenue, approximately 1.5 miles to the track, which will be on your left.

* Mobil station 2 blocks south of Rockton Rd. on Blackhawk Blvd.

First Driver

Year/Car Make/ Model/ Permanent Car Number

Phone

E-mail

(circle ALL applicable) Member Non-Member Guest of: _____

Run Group:

[Instr/Red] [A/Black] [B1/White] [B2/Yellow] [C/Green]

Prior Experience: _____

Second Driver (same car)

Phone

E-mail

(circle ALL applicable) Member Non-Member Guest of: _____

Run Group:

[Instr/Red] [A/Black] [B1/White] [B2/Yellow] [C/Green]

Prior Experience: _____

Pre-registered Entrance Fees received by May 10, 2004:

Instructor - \$30.00	\$ _____
Member First Driver - \$170	\$ _____
Family Member-2nd Driver - \$100 *	\$ _____
Non-Member - \$170	\$ _____
Registration received after May 10th, or	\$ _____
On site registration add \$10	
	Total \$ _____

* The \$100 fee only applies to 2nd family member who drives the same car as the first driver.

Make check payable to: PCA- Chicago Region

Mail to: Todd Conforti - Blackhawk Drivers' ED Registrar
553 West Carboy Road
Mount Prospect, IL 60056
(847) 382-9656 home (847) 952-0070 work
e-mail: tlcontrols@aol.com

For more information on Track Events, Schedules, Tech & Safety Requirements use the WEB at WWW.PCA-Chicago.org
For more Blackhawk information go to
WWW.namotorsports.com/Tracks/Blackhawk.html.

Chicago Region - Zone 13 Porsche Parts/Car Auction & Swap Meet



Have you ever heard the saying “**One man’s garbage is another man’s treasure**”? Well, have we got a load of both for you! On **Saturday, May 22nd** the Chicago Region, along with invited members from all Zone 13 Porsche Clubs, will be hosting our largest swap meet in Chicago to date. If you are a **Porsche Pack Rat** like us, and have quietly accumulated all the parts that have fallen (ah um) off your Porsches over the years, then this is the time to take action and clean house, garage, basement, trailer, or whatever. John Ruther of Northstar Motorsports will be our host for this year’s sale extravaganza. Located in Barrington, IL, John’s facility is able to accommodate all who wish to attend. Spaces will be offered both indoors and outdoors on a first come - first served basis. In addition, we will have licensed Auctioneer and Chicago Region Member Jim Drury available to whip all car buyers into frenzy. Watch future editions of the Chicago Scene for more info.

Entry: \$25.00 per Indoor Space (limited availability so reserve early!)
 \$20.00 per Outdoor Space
 All spaces include 1 eight-foot table and 2 chairs

\$35.00 per car for “For Sale” Car Corral - No buyer’s fee for auction.

Silent Auction on Selected Items

Date: Saturday, May 22nd 2004
Time: 9:00am - 4:00pm
 (Vendors may begin to set up at 7:30am)
Place: Northstar Motorsports
 28144 W. Industrial Ave., Suite 108
 Barrington, IL 60010



Food and drinks can be purchased on site from Kookers of Barrington, IL.

Event Contacts: Nick Brenkus (847) 426-9111 or Scott Lynn (630) 443-4380

Send check payable to Chicago Region PCA to: Nick Brenkus
 17 N 560 Hidden Hills Trail
 West Dundee, IL 60118

Reservation for Swap Meet Space for: _____

Name

phone

____ # of indoor spaces @ \$25.00
 ____ # of outdoor spaces @\$20.00
 ____ # of Cars For Sale @ \$35.00

_____ \$\$ Total

Auction & Swap Meet Schedule

Summary of the day's activities

7:30	Registration and vendor set up
8:00	Breakfast (by Kookers of Barrington)
9:00	Swap meet opens to buyers
10:00	Live Auction signup
10:15	Silent Auction signup
12:00	Lunch (by Kookers of Barrington)
1:00	Live Auction of Car/Parts
2:00	Silent Auction
3:00-4:00	Last minute wheeling and dealing

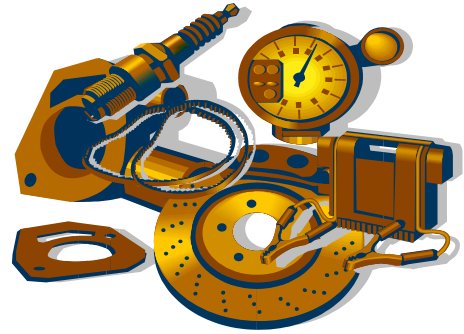

Guidelines for Auction Items

Live Auction Items: Porsche car or unique Porsche collectable items. (Value in excess of \$100.00).

Silent Auction: Items with values considered higher than \$25.00.

All members that purchase a table space may enter both the live and silent auction at no charge.
All others may enter up to three items for \$10.00.

All auctions items may have a reserve set prior to auction.

Directions to Northstar Motorsports, 28144 W. Industrial Ave., Suite 108, Barrington.

From the East:

Route 22 West to Kelsey Rd., South on Kelsey to Pepper Rd. (approx. 1/2 mile), East on Pepper Rd. to Industrial Ave., East on Industrial, 2nd building on left.

Route 14 (Northwest Highway) West to Pepper Rd. (approx. 3 miles West of Rt. 59), North on Pepper to Industrial Ave., East on Industrial, 2nd building on left.

I-90 West to Barrington Road Exit, Exit Barrington Road North, West on Rt. 14 (Northwest Highway) to Pepper Rd. (approx. 3 miles West of Rt. 59), North on Pepper Rd. to Industrial Ave., East on Industrial, 2nd building on left

From the North:

Rt. 59 South, to Rt. 14 (Northwest Highway) West to Pepper Rd. (approx. 3 miles West of Rt. 59), North on Pepper Rd. to Industrial Ave., East on Industrial, 2nd building on left.

From the West:

I-90 East to Route 59, Exit Rt. 59 North, to Rt. 14 (Northwest Highway) West to Pepper Rd. (approx. 3 miles West of Rt. 59), North on Pepper Rd. to Industrial Ave., East on Industrial, 2nd building on left.

From the South:

Rt. 59 North, to Rt. 14 (Northwest Highway) West to Pepper Rd. (approx. 3 miles West of Rt. 59), North on Pepper Rd. to Industrial Ave., East on Industrial, 2nd building on left.

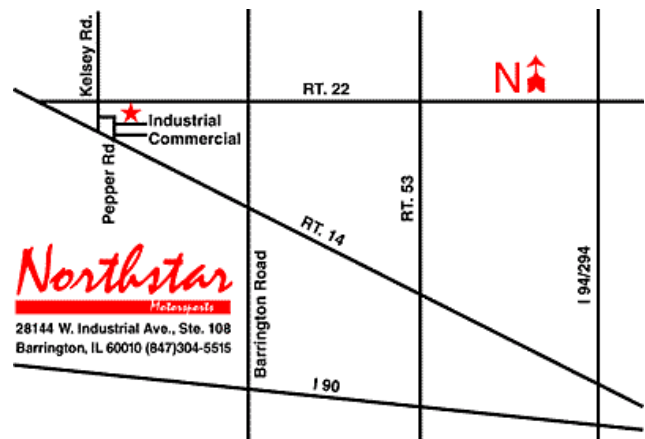

Please CHANGE your 2004 Membership Directory to show John Ruther's correct home telephone number as 847-304-1222; work telephone number is 847-304-5515.



Driver's Education Auto Physical Damage Insurance

"Don't run the risk of involving your regular insurer in the event of an 'oops.' Know that you are properly covered while on track in Driver's Education events. Put a Driver's Ed insurance policy from ACI on your equipment list."

John D. Heckman

Accredited Advisor in Insurance

Driver's Education instructor for PCA, BMWCCA, Viper Days and others

American Collectors has been providing specialty vehicle insurance to car enthusiasts since 1976. It would be our pleasure to assist you with a no-obligation rate quote.

1 (847) 253-2225

Dale Costello

www.planninghelp.com

We also provide coverage for Classic / Collectable Autos



AMERICAN COLLECTORS INSURANCE, INC.

Pride, Performance, Passion



Select Pre-Owned Sports Cars

2215 W. Belmont Avenue
Chicago, IL 60618
773.325.1690
midwestperformancecars.com

MIDWEST



PERFORMANCE CARS

Autocross I

May 23, 2004

Hawthorne Race Track (parking lot)
 3501 South Laramie
 Stickney/Cicero, IL

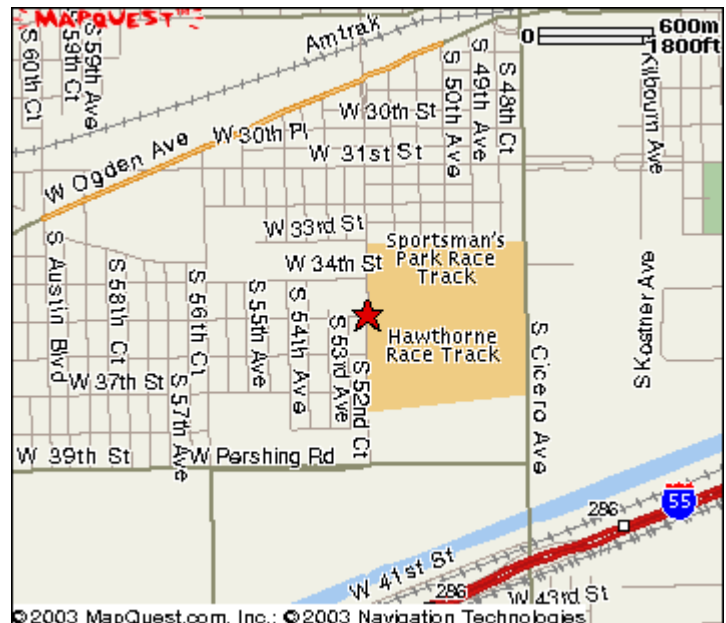

- 9:00 - 10:00 am Registration* and Tech
- 10:15 am Tech closed
- 10:15 am Driver's Meeting
- 10:30 am First car off
- 3:30 pm Trophy Presentation

Please pre-register

Driver #1	\$35.00 Member	\$40.00 Non-Member Guest - Member MUST be present
Driver #2	\$15.00 Family Member	\$40.00 Non-Member Guest - Member MUST be present
	\$35.00 Member sharing car with other Member	

GENERAL RULES: Required - Snell 1990 helmet, full-length pants, long-sleeved shirts, socks and full shoes. Member may bring one guest. Guest may drive member's Porsche or a two door sports car. Associate Member driving a non-Porsche is considered a Guest. Maximum two drivers per car. Member MUST be present with Guest. Only first car driven will trophy. Valid driver's license at Registration. *On-site registration, checks only, please.

Mail (with check) to: Jeff Girard 815.838.3000 dukiemaxgirard@aol.com
 17439 Woodbrook Lane
 Lockport, IL 60441-7416

Driver #1 _____

 Phone number

Car Model Chicago Region Permanent #
 Member Guest*

Driver #2 _____

 Phone number

Car Model Chicago Region Permanent #

* _____ Total enclosed _____

Guest of Member MUST be present Checks payable to PCA Chicago Region

Club Racing Scene

by Susan Shire, PCA Club Racing Program Coordinator and John Ruther, 2004 Chicago Region Chief Driving Instructor

2004 Club Racing Schedule

Dates	Event	Region	Region Contact
Apr 3/4	Road Atlanta	Peachstate	Ian Scott 770.623.0213 idsqa@bellsouth.net
Apr 23/24/25	Rennsport Reunion at Daytona	Non -PCA	http://www.gorace.com/
Apr 30/May 1/2	Laguna Seca Raceway	Zone 7	Masuo Robinson 408.399.5228 masuo@ix.netcom.com
May 1/2	Las Vegas Motor Speedway	InterMountain	Tim Martin 801.733.4439 martin@sisna.com
May 8/9	Mid Ohio Sports Car Course (Note: Date in Pano is incorrect)	Mid Ohio	Jeff West 740.745.2136 william.west@dla.mil
Jun 5/6	Mid America Motorplex	Great Plains	John Krecek 402.505.9911 krecek@cox.net
Jun 4/5/6	Barber Motorsports Park*	Alabama	Bill Mitchell 205.251.9263 eas930@bellsouth.net
Jun 11/12/13	Watkins Glen International*	Zone One	Botho von Bose 800.567.1566 BvonBose@lomtd.com
Jun 11/12/13	Portland Rose Cup	Oregon	Jay Culbertson 503.517.3338 Jay.Culbertson@TCMcorp.com
Jul 3/4	Gingerman Raceway*	SE Michigan	Jerry Door 248.661.4362 jdoor@pressmaster.com
Jul 9/10	Texas Motor Speedway	Maverick	Bryan Henderson 817.354.6045 BDHender@comcast.net
Jul 17/18	Putnam Park	OhioValley	Dave Schardt 937.299.0610 dschardt@wheel1.com
Jul 30/31/Aug 1	Mosport*	Upper Canada	Susan Davis 313.506.5659 SusanD@korotkin.com
Aug 7/8	Brainerd International*	Nord Stern	Roger Johnson 763.557.9578 Rsamerica93@comcast.net
Aug 21/22	Summit Point	Potomac	Dave Derecola 301.743.5948 clubrace@aol.com
Aug 28/29	BeaveRun MS Complex*	Allegheny	Linda Hamerly 724.443.2086 linda@apexperformance.net
Sep 4/5/6	Road America*	Chicago	Pete Hackenson 847.604.4795 roadamerica@pca-chicago.org
Sep 11/12	Pueblo Motorsports Park	Rocky Mtn	Jeff & Tricia Mitchell Jeff_Mitchell@peoplesoft.com
Sep 17/18	Lime Rock Park	Conn Valley	John Howard 845.534.3358 race_director@cyrpca.org
Sep 18/19	Putnam Park	Central Indiana	Jason Collins 317.858.1864 jcoll-1@rocketmail.com
Oct 1/2/3	Virginia International Raceway	First Settlers	Ramon Rodriguez 757.229.8123 RacingMD@aol.com
Oct 2/3	Hallett Motor Racing Circuit	Cimarron	Gary Bernard 918.254.1104 gary@bernarddesign.com
Oct 29/30/31	Heartland Park*	Kansas City	Sean Reardon 785.766.7585 sreardon@kcrpca.org
Nov 5/6/7	Carolina Motorsports Park*	Carolinas	Dick Lane 803.932.7988 dicklane@sc.rr.com
Nov 20/21	NP Raceway	Mardi Gras	Brad Bradford 504.835.7874 sandrahh@pipeline.com
Dec 4/5	Roebing Road	Florida Crown	Dave Rodenroth 904.251.9552 racer914@earthlink.net
	* Indicates an enduro event		



What Is PCA Club Racing?

PCA Club Racing is an organized wheel-to-wheel competition race series between drivers who hold PCA Club Racing licenses. Club Racing has classes for every type of Porsche. Eligibility, class definitions, and safety equipment requirements may be found in the 2004 Club Racing Rule Book at www.pca.org/pca/clubrace

Where Do I Find Information About PCA Club Racing?

Contact Susan Shire in the Club Racing Office at 847.272.7764 or at PCAClubRace@aol.com or consult the PCA Club Racing web page at www.pca.org/pca/clubrace

Who Do I Contact In The Chicago Region For A Certification Of Ability And Experience (required for all Rookie License Applicants)?

John Ruther is the Chicago Region's Chief Driving Instructor. John may be reached at chief_instructor@pca-chicago.org or at 847.304.5515



Chris Inglot's 1991 944 S2 at the 2004 PCA Sebring Club Race

Place In Class			Class	Year	Model	Race
3	Jeremy	Goldberger	C	1993	RS America	Sebring Enduro
9	Robert	Heniff	C	1993	911 RSA	Sebring Enduro
4	Nicki King	Rob King	D	1995	993	Sebring Enduro
2	Bob	Klaskin	E	1989	944 Turbo	Sebring Enduro
2	Chris	Inglot	F	1991	944S2	Sebring Enduro
14	Mike Faems	Jeff Phillips	F	1989	944 S2	Sebring Enduro
3	Claude	Reed	G	1976	911 Targa	Sebring Enduro
6	Gary	Knoblauch	GT4S	1976	911 RSR	Sebring Enduro
3	Ken	Lindgren	GTA	2001	GT3RS	Sebring Enduro
9	Scott	Sanda	GTC3	2002	996 Cup	Sebring Enduro
21	Al	Jorgensen	GTC3	2004	GT3 Cup	Sebring Enduro
9	Jeremy	Goldberger	C	1993	RS America	Sebring Sprint
3	Robert	King	D	1995	993	Sebring Sprint
5	Robert	Heniff	D	1993	911 RSA	Sebring Sprint
5	Bob	Klaskin	E	1989	944 Turbo	Sebring Sprint
2	Chris	Inglot	F	1991	944S2	Sebring Sprint
15	Mike	Faems	F	1989	944 S2	Sebring Sprint
2	Claude	Reed	G	1976	911 Targa	Sebring Sprint
1	Gary	Knoblauch	GT4S	1976	911 RSR	Sebring Sprint
6	Ken	Lindgren	GTA	2001	GT3RS	Sebring Sprint
11	Scott	Sanda	GTC3	2002	996 Cup	Sebring Sprint
25	Al	Jorgensen	GTC3	2004	GT3 Cup	Sebring Sprint



(top) Claude and Rachel Reed's 1976 911 Targa

(bottom) Jeremy Goldberger in his 1993 RS America



Some of our BEST at the 2004 PCA Sebring Club Race

photos by Jason Meredith



(top) Gary Knoblauch's new 1976 911 RS

(left) Rob and Nicki King's 1995 993

(bottom) Bob Klaskin in his 1989 944 Turbo





Road America Drivers' Education 2004

Friday, May 28 – Sunday, May 30, 2004

On behalf of the Chicago Region, we invite you to register for the first of two events that we will be hosting this year at historic Road America in Elkhart Lake, WI.

Road America consists of fourteen turns, three long straights, and four total miles of winding track cut through the Kettle Moraine area of southern Wisconsin in Elkhart Lake. Not only is it the longest road course in North America, but one of the most exciting and picturesque racetracks in the world.

Registration for this event is open to all Porsche sportscar drivers including new Drivers' Education participants. Pre-registration is required for this event, as on-site registrations will not be accepted. For drivers who have never been on a road course before, our high level of instruction will allow you to better learn the capabilities of your Porsche within a controlled environment. Novice drivers who wish to participate in this event should return the completed registration form with payment today as space is limited to 50 novices and this event is traditionally a sell out! We strongly recommend that all new Drivers' Education participants first attend the Autocross Driver's School on Sunday, April 25th as well as the Novice Driver's School at Blackhawk Farms Raceway on Wednesday, May 12th, in preparation for driving this challenging track.

Novice drivers will begin their weekend by attending a mandatory *Novice Orientation Meeting* on *Thursday evening, May 27th at 8:00 pm sharp* at Siebkens Resort located on Elkhart Lake. Friday, May 28th, will be devoted **EXCLUSIVELY** to new Drivers' Education participants and their instructors. Instruction includes participation in a classroom training session led by professionals from the Skip Barber Program, followed by controlled car handling exercises with the help of SCCA Instructors. All new Drivers ED participants will also be assigned a PCA Instructor who will work with them throughout the weekend to help improve his or her driving skills.

The format for Saturday and Sunday will include experienced drivers and will consist of four run groups as follows:

- Group 1** **Our most experienced drivers - usually, but not always, the fastest cars.**
- Groups 2 & 3** **Our next most experienced drivers - somewhat slower than Group 1.**
- Group 4** **New Drivers' ED participants and others still fairly new to Road America.**

Before you arrive at the track, it is your responsibility to thoroughly check your car and complete a 2004

Chicago Region Tech Sheet. (available in this issue of the Chicago Scene). Although you may perform this tech inspection yourself, we strongly recommend you consider using a mechanic familiar with what it takes to properly prepare a Porsche for use on the track. In either case, please pay close attention to the specifics detailed on the Tech Sheet, especially concerning brake fluid and brake pads.

For Groups 1 thru 3, a five point harness with race seat or a six point harness with stock or race seat is mandatory for the driver, and if you wish to have an instructor ride with you, the same type of harness/seat requirements must be installed on the passenger side. Novice Class only may run stock Porsche seats and three point belts. Mandatory clothing for this event includes a SNELL approved SA 1995 or newer helmet, long sleeve cotton shirt, long pants and socks - made of non-synthetic material, and closed toe shoes. Recommended, but not mandatory are driver's suits, driving gloves and shoes, and a protective neck brace all made of Nomex or similar fire-resistant materials, and a properly mounted fire extinguisher. As a reminder, please check the date on your helmet **NOW** as it will be checked at tech inspection. Remember that if you do not pass tech inspection, you will not be permitted to drive! For more information on safety equipment for the driver and vehicle please reference the Chicago Region 2004 Tech Sheet.

The event registrar will assign car numbers prior to the event and ALL cars must display those numbers on each side of the car and on the front hood. If you would like a permanently assigned Region Number, please contact Ed Leed (847.382.6911). Numbers must be at least 6 inches tall on the sides and 8 inches tall on the hood. Shoe polish is not acceptable! If the corner workers cannot read your car's numbers at speed, you will be black-flagged and not be permitted out again until the deficiency is corrected. Once you have received your number assignment from the registrar, we recommend that you find a local sign shop that can create inexpensive static cling numbers.

All cars that participate in this event must not exceed the maximum Road America noise restriction level of 108 decibels. Please ensure that your car is in compliance with this sound limit in advance. Monitoring equipment will be used throughout the weekend.

Approximately two weeks before the event, participants will receive a confirmation packet via email or US mail that will include a copy of the *Rules of Road America*. Please take the time to review them in detail before you arrive at the track. As these rules are set by Road America it is important that you and all of your guests are in full compliance.

Road America Drivers' Education 2004 Committee Members

Pete Hackenson	Event Chairman	847.604.4795	roadam.pca-chicago@comcast.com
Keith Clark	Event Co-Chairman	630.690.3381	ClarkFNFlying@aol.com
AJ Tiller	Volunteer Coordinator	708.957.8262	AJ2ManyCars@aol.com
Mary Anne Nowakowski	Event Registrar	847.929.1831	nowakowskim@permapipe.com
John Ruther	Chief Driving Instructor	847.304.5515	chief_instructor@pca-chicago.com
Toby Duckett	Tech Coordinator	630.248.7680	Toby@mc2fyi.com
Todd Conforti	Safety Coordinator	847.382.9653	TLControls@aol.com

In addition to the mandatory Novice Orientation Meeting on Thursday evening at Siebkens Resort, there will also be trackside *Mandatory Driver's Meetings* on Friday morning for Novices and Instructors, and on both Saturday and Sunday mornings for **ALL DRIVERS**. Each of these meetings will begin at 7:30 AM sharp. Any driver missing any of these meetings that address safety and policy issues for the weekend will not be allowed to drive. Regarding safety, we ask all participants to provide some personal medical information as part of the registration form. The Chicago Region believes in taking a proactive approach to your personal well-being and this information will be made available only to the track physicians in the remote possibility it is needed. All medical information will be destroyed after the event.

Space for this event is limited and we recommend that you pre-register early! Prior to April 1st we will accept pre-registrations from Chicago Region members **ONLY**. After that date, pre-registration will open to all Porsche sports car drivers on a first-come, first-serve basis. Notification (by e-mail or US-mail) of acceptance will be provided by the registrar. If you are planning to attend this event, this would also be a good time to make your room reservations as many of the hotels in and around Elkhart Lake will fill up quickly for the holiday weekend. A listing of places to stay is provided in this newsletter. Please note that we have a block of rooms reserved for the Chicago Region Porsche Club at various inns in the Elkhart Lake and Plymouth Wisconsin area. Room blocked inns are indicated on the "Places to Stay" sheet. You must mention that you are a Chicago Region PCA member.

On Thursday, May 27th, from 4:00 pm until 7:00 pm, Registration for New Drivers Education Participants and Instructors will be open at Siebkens Resort in Elkhart Lake. Registration for all other drivers will be at the Registration Building at Road America from 4:00 pm - 7:00 pm on Friday, May 28th and on Saturday, May 29th from 7:00 am - noon. All drivers must present a valid driver's license and a current PCA membership card at registration. The Tech Crew will also be on hand to scrutinize your car and helmet. If your car is not available for Tech on Thursday or Friday afternoon, it must pass inspection on Saturday morning following the driver's meeting. No cars will be allowed to run without a Tech Inspection sticker!

There will be 24-hour security at the track Friday through Sunday evening. Road America will allow participants to camp on the grounds for a fee of \$50 for motorhomes and \$35 for tents. Electrical hook-ups will also be available for \$20. These fees are payable directly to Road America. **Please note that the track gates will close promptly at 7:00 PM on Sunday, May 29, and everyone must vacate the property prior to that time.**

If you are looking for an easy way to get around the pits and track viewing areas, consider renting a golf cart. Golf cart rental reservations must be made by April 30th. Cart renters are responsible for any damage and a minimum age of 16 years is required to drive the carts.

The registration fee includes a **RADE. 2004** shirt. Please indicate your shirt size on the pre-registration form. Extra shirts, at \$20 each, may be pre-purchased if payment and size are included with the registration fee. A very limited supply of shirts will be available for purchase during the event.

If you would like additional information regarding this event, we have established a 24-hour Information Hotline at 847.604.4795. Please leave a message and the appropriate committee member will return your call. Committee members may also be reached at the phone numbers and e-mail addresses listed above.

If you are hesitant to put your car on the track but are curious about the event, join us at the track. A great way to learn about any Chicago Region event is to volunteer to help out. We are always in need of volunteers. At track events, helping out in registration, at tech, or on grid is a great way to make new friends and see lots of great cars. Either fill out and return the Volunteer Form or contact AJ Tiller.

Returning this year is low speed track touring after lunch on Saturday and, time permitting, on Sunday. This is your chance to take the family out in the family minivan, SUV, or Cayenne and show them the beauty of Road America! We will ask for a \$10 donation for this privilege, with all proceeds going to charity.

Join us over Memorial Day Weekend at Road America for one of the best track events of the season!

Pete Hackenson and Keith Clark
Road America Drivers' Education

DRIVER MEDICAL INFORMATION

For second driver, please photocopy this sheet, complete, and submit with event registration form



Name _____ Age _____ Birth Date _____

List any medication currently used (including eye drops) _____

Contact lenses? Y N Last tetanus shot date _____ Blood type _____

Allergies (including asthma, hay fever, medications or drugs) _____

List any current Medical Conditions _____

Describe any medical changes since your last physical _____

Physician's Name _____ Phone _____

NOTE: This information is kept confidential and is to be utilized only in the event of a medical emergency. This form will be destroyed after the event.

POLICIES: This registration form must be signed. Your signature below signifies acceptance of these policies.

- The PCA Chicago Region reserves the right to deny registration for or admittance to this event or request the removal from this event of any person as it sees fit.
- Incomplete Registration forms will not be accepted and will be returned with no registration place held. Late fees will apply.
- The Chicago Region's policy regarding fees incurred and damage caused at the track is that the party or parties responsible will be required to reimburse Road America for any fees or physical damage caused to the track or its facilities, including (but not limited to) the clean up and removal of any spilled oil, coolant, brake fluid, discarded tires, or late exit. These are not covered in your registration fee.
- I agree to indemnify and hold harmless the organizers of this event and their agents with respect to the condition and preparation of my car or any subsequent failure or damage to my car or its occupants as a result of such failures. I acknowledge that at all times I remain solely responsible for the safety and road worthiness of my car.
- I give permission to any hospital, institution or physician to furnish any information regarding my condition.

Signature _____ Date _____ In Case of Emergency Notify:
 Name _____ Phone/cell phone/pager _____
 Relationship _____ At track? Y N At local hotel? (name) _____

RADE 2004 FEE SCHEDULE

EARLY REGISTRATION

LATE REGISTRATION

Fee includes shirt

Postmarked by 4/27/04

Postmarked after 4/27/04

First Driver

___ Novice	Friday, Saturday & Sunday	\$ 400.00	\$ 430.00
___ Instructor	Friday, Saturday & Sunday	\$ 325.00	\$ 355.00
___ Other First Driver	Saturday & Sunday	\$ 325.00	\$ 355.00

Second Driver (family or affiliated PCA member only)

___ Novice	Friday, Saturday & Sunday	\$ 215.00	\$ 245.00
___ Other Second Driver	Saturday & Sunday	\$ 180.00	\$ 210.00

Second Driver (non-family/non-affiliated PCA member, non-PCA member)

___ Novice	Friday, Saturday & Sunday	\$ 400.00	\$ 430.00
___ Other Second Driver	Saturday & Sunday	\$ 325.00	\$ 354.00

NO REFUNDS FOR CANCELLATIONS AFTER MAY 13, 2004
A \$25.00 PROCESSING FEE WILL BE DEDUCTED FROM ALL REFUNDS.
 (CANCELLATIONS MUST be in writing)

Driver(s) Fees \$ _____

Extra shirt(s S M L XL XXL XXXL # _____ @ \$ 20.00 EACH \$ _____

Golf Cart Rental : 3 day rental of 2 seat cart # _____ @ \$ 225.00 EACH \$ _____

Golf Cart Rental: 2 day rental of 2 seat cart # _____ @ \$ 150.00 EACH \$ _____

Make checks payable to PCA Chicago Region **TOTAL enclosed** \$ _____

Mail this two page registration form and check (payable to PCA Chicago Region) to:

Mary Anne Nowakowski, RADE 2004 Registrar
527 South Rammer Avenue
Arlington Heights, IL 60004

PLACES TO STAY WHILE VISITING ROAD AMERICA

UPDATED FOR 2004

52 Stafford – An Irish Guest House
Plymouth, WI – 920.893.0552

The American Club
Kohler, WI – 800.344.2838

AmericInn Motel - Plymouth
Plymouth, WI – 920.892.2669
***Mention Chicago Porsche Club
for Block Reservation Rates***

AmericInn Motel/Suites
Sheboygan, WI – 920.208.8130

Baymont Hotel, Plymouth, WI.
920-893-6781 (NEW)
***Mention Chicago Porsche Club
for Block Reservation Rates***

Baymont Inns
Sheboygan, WI – 920.457.2321

Best Value Parkway Motel
Sheboygan, WI – 800.341.8000

Blue Harbor Resort
Sheboygan, WI.
866-701-2583 (NEW)
***Mention Chicago Porsche Club
for Block Reservation Rates***

Breeze Inn to the Chalet Motel
Mequon, WI – 414.241.4510

Brownstone Bed & Breakfast
Sheboygan, WI – 920.451.0644

Comfort Inn
Sheboygan, WI – 800.228.5150

Grand Hotel
Sheboygan – 920.458.1400

Harbor Winds Hotel
Sheboygan, WI – 920.452.9000

Hillwind Farm B & B
Plymouth, WI – 877.892.2199

Holiday Inn Express
Sheboygan, WI – 920.451.8700

Imperial Motel
Sheboygan, WI – 920.458.3578

Inn on Woodlake
Sheboygan, WI – 800.919.3600

Krupp Farm Homestead B&B
New Holstein, WI – 414.782.5421

Lakeland College
Howards Grove, WI – 920.565.1248

The Osthoff
Elkhart Lake, WI – 800.876.3399
***Mention Chicago Porsche Club
for Block Reservation Rates***

Pinehurst Inn
Sheboygan Falls, WI – 920.467.4314

Plymouth Inn
Plymouth, WI – 920.893.5623

Ramada Inn Downtown
Sheboygan, WI – 800.909.8770

Riverview Spa Suites
Sheboygan, WI – 920.451.9576

Rochester Inn
Sheboygan Falls, WI – 920.467.3123

Safe Harbor Inn
Fond du Lac, WI – 920.923.0223

Saukville Super 8 Motel
Saukville, WI – 414.284.9399

Select Inn Fountain Park
Sheboygan, WI – 800.909.8770

Sheboygan Super 8 Motel
Sheboygan, WI – 920.458.8080

Siebkens Resort
Elkhart Lake, WI – 920.876.2600
***Mention Chicago Porsche Club
for Block Reservation Rates***

Victorian Village
Elkhart Lake, WI – 920.876.3323
***Mention Chicago Porsche Club
for Block Reservation Rates***

Windy Mare
Kiel, WI – 920.894.2284

Wisconsin Aire Motel
Random Lake, WI – 920.994.4501

Yankee Hill Inn B & B
Plymouth, WI – 920.892.2222

Campgrounds

Cedar View Camper Rentals
Kiel, WI – 920.894.7884

Hoef's Resort Campground
Cascade, WI – 920.626.2221

Plymouth Rock Camping Resort
Plymouth, WI – 920.892.4252

Mark & Dean's Camper Rental
Kiel, WI – 800.894.7181

Westward Ho Camp Resort
Glenbeulah, WI – 920.526.3407

Elkhart Lake Information & Booking available private Houses

Elkhart Lake Tourism Commission and the Elkhart Lake Area Chamber of Commerce

41 E. Rhine St.,
Elkhart Lake, WI 53020
920 876-2922
Toll Free - 1 877-ELKHART
elcoc@excel.net

Porsche Club of America - Chicago Region Social Event

For the entire family and invite your friends!



and the Kane County Cougars Versus West Michigan White Caps (Detroit Tigers)

MEMBER APPROVED EVENT

Saturday, June 5, 2004

Game time 6:00 PM

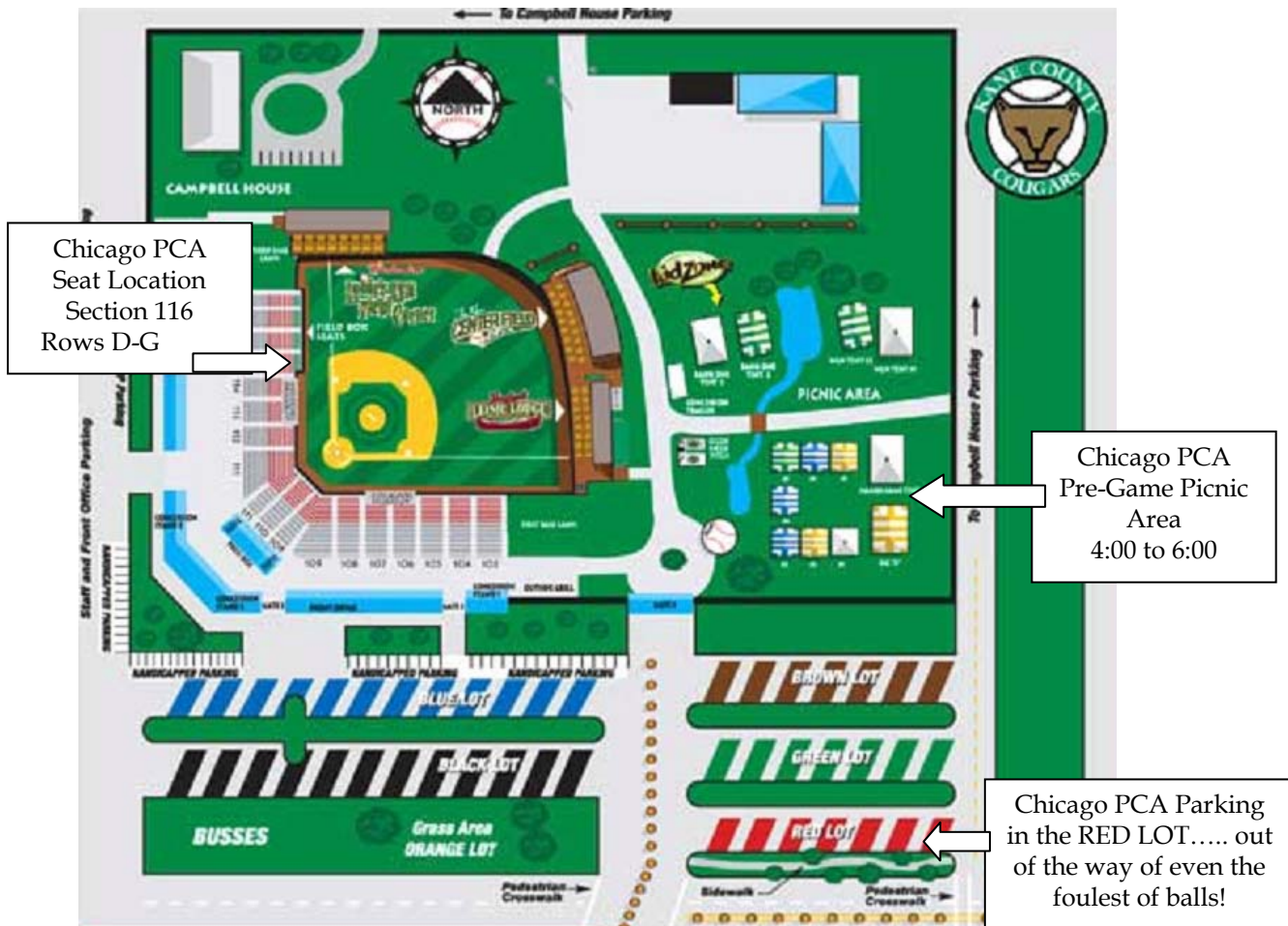

- Great up close box seat.
- Pre game food starting at 4:00pm.
- Soda included for the entire game.
- Fantastic post game fire works display.
- Kids of all ages from 1 to 101 get to run the bases after the game!

Special Porsche / paved preferred parking for only \$2.00 per car.

SPACE IS LIMITED. RESERVE YOUR SEATS TODAY!

ONLY \$25.00 per PERSON

Chuck and Melissa LaMantia (630.510.7418) or Keith and Karen Clark (630.690.3381)
Contact info for SOCIAL available in the Scene or www.pca-chicago.org under CONTACTS.

Technical Scene

How Often Should I Change My Oil?

by Dan Metz, Potpourri, May 2003

Car enthusiasts have been asking this question since the first car was built! How do you know when you oil is “worn out” and should be replaced? And what “wears out” oil anyway?

Mostly, oil *doesn't* wear out. It does, however, become *contaminated* with products of combustion that manage to make their way past the piston rings of the engine. These include unburned gasoline, water vapor, partially combusted gasoline and contaminants that get past the engine air cleaner, through the intake system and then past the rings. All of this stuff combines to dilute the oil, introduce particles into it and prevent its lubricity from reducing engine friction and carrying away heat.

Ever notice how quickly oil gets dirty? Seemingly only a few miles after an oil change, the stuff appears

almost black again! That's because modern oils contain emulsifiers and detergents that clean the interior of an engine. To the extent that those additives are doing their job, the oil gets dirty — fast! That's what it is supposed to do, so don't be alarmed. Also, have you ever checked your oil, found it full-up, then taken an extended drive at high speed, only to find when you re-checked the oil only a few hours later it was down two quarts?

What's likely is that the oil had a lot of contaminants in it that were heated to their vaporization point during the drive and then eventually outgassed either through the exhaust or crankcase ventilation systems. Not to worry - your baby isn't using a quart/100 miles yet!

Obviously, then, how often to change oil depends not just on miles accumulated but also on *severity* of driving. Lots of stop and go driving is the hardest service of all. Contaminants are continually introduced (worse with a cold

engine not running properly for the first several seconds after you light it off) and they don't get vaporized. Best is a lot of high speed driving, as detailed above. Regardless, it's probably good practice to change oil once or twice a year almost no matter how few miles you drive.

There are services that will analyze oil to determine its contamination and condition, and some modern cars even attempt to estimate severity so as to provide the driver with warning when a “sufficient” amount of use has taken place (BMW's come to mind here). But unless you operate a fleet of trucks, analysis isn't worth the money. Better to just be conservative. One set of gaskets for an engine overhaul (not to mention parts and labor!) costs more than several oil changes, even for air-cooled Porsches that take 12 quarts.

Pretty cheap insurance, wouldn't you say?

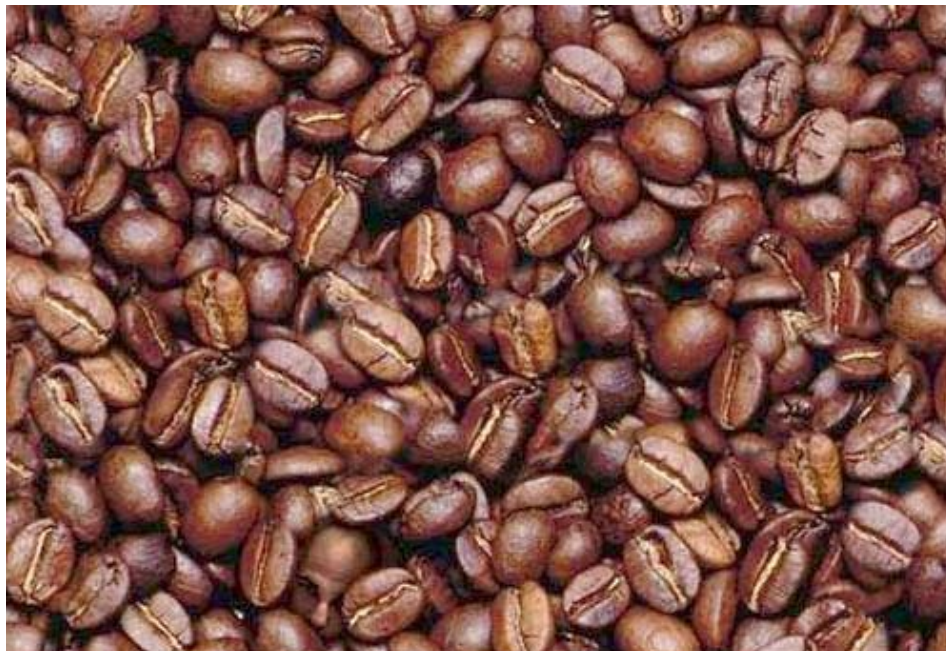

Find the man ... Trust me, he's there.

DO WE OR DON'T WE PAUSE CEMETERY RALLYE SUNDAY, JUNE 6, 2004



Registration Opens	10:30 a.m.	Meet at SUNRISE RESTAURANT
Driver's Meeting	11:00 a.m.	9 South 593 Rt. 47
First Car Off	11:31 a.m.	Sugar Grove, IL, 60544
Rallye Car Fee	\$20.00	630-466-5837

LOCATION: SUNRISE RESTAURANT is located at the northeast corner of junction Rte. 47 and Jericho Road, south of the downtown village of Sugar Grove. There is a Citco Station right next door for last minute fill up.

This rallye will be over the roads of southwest Kane County, Kendall and LaSalle Counties, which are all new to Chicago Region rallyists. The end point will be at Chicago West Restaurant in Sugar Grove at the junction of Rte. 47 and Main Street. Rallyists will enjoy the open roads of these counties where it seems the housing construction has not found them yet.

To get to the start point, take I88 west from Aurora and take the exit for Rtes. 56, 47, 30 Sugar Grove and follow the exit road to exit for Rte. 47 South. Sunrise Restaurant is south on Rte. 47 approximately 2 miles on the left just before Jericho Road.

Questions can be directed to the Rallyemaster, Ken Pesavento at 630-469-1546 or email at Kenneth_a_Pesavento@ml.com.

Mail Registration to Ken and Nikki Pesavento, 2 S 430 Canterbury Court, Glen Ellyn, IL, 60137.

DRIVER: _____ Phone # _____

Member ___ Applicant ___ Guest of _____

NAVIGATOR: _____ Phone # _____

Member ___ Applicant ___ Guest of _____

Car Model _____ Color _____ SOP _____ Touring _____ Novice _____

Rallye Car Fee: \$20.00 Please make checks payable to **PCA/Chicago Region**.

Permanent Car Numbers

by Ed Leed

As you prepare for the upcoming autocross and drivers education season you may decide to get a permanent number for your Porsche. Although the RADE, Blackhawk or Gingerman registrar may have given you a number last year, it is simply a temporary one for that specific event, not your permanent number. Another member may already own the number you are using and will likely be rather disappointed to see his number on your car at a future event. So you will need a permanent number of your own.

Shoe polish numbers are no longer acceptable because they are virtually unreadable by corner workers, so you have the choice of vinyl adhesive numbers, static cling numbers, magnetic numbers or painted numbers.

Painted numbers seem to have a rather serious commitment attached to them so that means magnetic, vinyl adhesive or static cling numbers may be the answer for you.

Static cling numbers have a habit of blowing off at speeds that are really

fun, so that leaves magnetic or vinyl adhesive numbers.

Magnetic numbers are convenient but can cause microscopic scratches and occasionally may blow off. It's a good idea to tape your magnetic numbers so they do not vibrate and cause scratches or blow off.

Vinyl adhesive numbers won't blow off and can be removed after an event but can become expensive mistakes if you tear them when you take them off.

Numbers made from contact paper are cheap alternatives, by the way.

The list will tell you which numbers are available.

Many unused numbers have been released this year, including many two digit numbers.

If you previously have been issued a number and see it on this list, contact me immediately if you want to keep it. If I do not hear from you by April 15th, it will be reassigned to the first person requesting it.

If your favorite number is not on the list, it's taken.

Be aware that I get number requests on a daily basis this time of year. Although a number appears on the list does not mean it will still be available by the time this list is printed. Some two digit numbers are now available and to earn a two-digit number you must be a regular entrant, worker or event chairman. To keep your number from year to year, you must use it at least twice over a two-year period.

Please email me your list of three to five choices in preference order. You will need a number for each person who will drive the car at an event. Remember to include the year and model Porsche that the number will be used for.

Numbers are assigned on a first come, first served basis.

Email your car number request, Porsche year and model to me at Leedlast@hotmail.com or fax them to 847-382-3562.



R.A. Adams
ENTERPRISES, INC.

- TRAILERS • HITCHES •
- TRUCK EQUIPMENT •
- Full Service / Electrical
- Custom Paint / Graphics
- Full Line of Accessories

2600 W. RTE. 120, MCHENRY, IL
(3/4 MILE EAST OF FOX RIVER)

(815) 385-2600
www.raadams.com

OPEN: MON-FRI 7:00 - 5:30
SATURDAY 7:00 - 1:00

• OVER 400 TRAILERS IN STOCK •
• FINANCING & NATIONWIDE DELIVERY AVAILABLE •
• FAMILY OWNED & OPERATED FOR OVER 45 YEARS! •



MPH
TECHNOLOGIES, INC

Small Business Computer Network Installation, Repairs, Security

www.mphtechnologies.com
michael@mphtechnologies.com
708.415.0769

Michael Hill
Network Integrator

The Midship Report: SWM (D) Seeks SWF (N)

Article and pictures by John Miller [Boxster_S@veryspeedy.net]

I've lost my navigator. I don't mean I've misplaced her ... it's just a more polite way of saying my girlfriend dumped me. Those of you that know me can't blame her. There were warning signs. The sort of things that you might blind yourself to. The sort of things that you try to overlook. But the deal-breaker was there: she doesn't like car travel.

I thought perhaps zipping around the country in a convertible Porsche might be a strong persuader ... it would work on me! In just the summer months last season I rolled up nearly 12,000 miles of road travel. She takes planes like they are cross-town buses. In case you missed last month's rant, let me recap: I HATE winter. It is the ANTI-Porsche season to me. Her favorite sport is snow skiing. My favorite winter activity is leaving. Not like in 'raking' leaves, but leaving as in leaving town - going somewhere warm and getting a rental car to drive around.

While categorizing oneself is hardly useful, I'd have to say I'm no box of candy. On the other hand being a car guy - a Convertible car guy ... a Convertible Porsche car guy doesn't exactly make me a Jerry Springer either. And I've never lied to Congress, traded stock on inside information or de-stabilized a

foreign government (ahhh, probably not, but don't hold me to that last one). And there is that seal grey Boxster in the garage ... so my statement ... ok, call it a (pathetic?) plea at the top of this column stands: Driver seeks Navigator for the PCA Rallyes ... or any Rallyes.

I went solo to a couple of rallyes last year in hopes of finding a navigator. Not a great plan, and so I worked the rallyes which turned out to be an excellent tutorial for actually running in rallyes - that much I can recommend. I started this year started off with the PCA Tulip Rallye. Many thanks to Dan Gallagher for putting on this event. I teamed up with Karl (the human GPS) Urban. Ahhhh, that is, Karl graciously allowed me to drive around the country side while he told me exactly where to stop, start, and turn. If the day job fizzles out, maybe I've got a fall back in driving a cab.

One lingering question: WHERE THE HECK WERE YOU? It turned out to be a picture perfect day. Clear, sunny (ok, a bit cold, but what do you expect for February in Chicago?). And you didn't even have to drive your Porsche. Did I mention that it was FREE? Geez, you really blew it passing up that one. Make it up - by going to the

Photo Rallye. Get a big marker and circle April 18. I'll be there ... I'm looking for a co-driver/Navigator.

Drop Top Desperadoes

I smirk when I see these people. The minute the sun shines long enough to get the temps into 50's and give the sensation of warmth, the convertible people are out running around with the top down (and no doubt, the heater on). I especially like it when the motorcycle guys (and girls?) are out riding on days like that - so desperate to enjoy something resembling tolerable weather ... Nature is only setting a trap for these people. Snow and sleet and other 's' words are out there waiting to happen.

And yet, there I was last Sunday doing the same thing. The occasion was the PCA Concours School. A fine sunny 60+ degree day (wasn't it only 30 days ago that the temp was -5?) for a drive to a local Porsche dealership and I seized the chance to put the top down on the Boxster. And to my relief, it did not rain or snow once during the day. The rest of the week was a different story.

Getting back to the Concours School (and Chili cook-off). Attendance seemed quite good. And it should be. These are your club events and you truly are cheating yourself not to attend. Even if you're not overly interested in participating in a particular type of event, you're always welcome to come out and watch. Or better still, help out. It's not actual work - there's very little labor involved and you get a front row seat to the action without having to actually use your own Porsche ... although isn't that the point of having it?

The Road Calls. I Answer.

I mentioned last month about the schedule conflict of the Hershey Swap meet and Rennsport Reunion coming up in April. This WAS a



Our Rallye vehicle - hint: it's the lesser aerodynamic of the two.



April WHAT?

And being that this is the April issue, I was going to drop in a bit of 'April Fools' - the car in the photo above does belong to me, and is a genuine Carrera GT. And the place selling it was having trouble getting rid of it, so I took it off their hands ... for ten dollars (US). Had I been less distracted (by other car stuff) I was going to manipulate the photo and 'place it' next to the Boxster in my garage. Now I have a full year to do that ... and no doubt, I still won't get to it until the very last minute.

April Fools ... \$10

dilemma that is no more. The participants and featured cars of Rennsport don't seem to approach the level of cars that were at the first Rennsport. I also posted a message to the (online) Boxster Board. Hands-down, nine out of ten Boxster-respondents voted for the

Hershey event. So, at the end of April, Hershey, PA is where you'll find me ... and several hundred other Porches. And enough parts to assemble your very own right on the spot. It's worth the drive and d encourage it.

Next Month: No idea - but in less than 6 hours (as I type this), I'm off to Montana for a 'motorsports' getaway. I should probably pack something.



Fischer Motors, Inc.

SPECIALISTS IN COMPETITION PERFORMANCE SERVICE

- High Performance Engine Work
- Hunter Wheel Alignment
- Race Suspension Tuning & Weight Balancing
- Transmission & Brake Conversions

Besides all sport related upgrades, we are a repair facility for German cars.

PORSCHE MERCEDES BENZ BMW VOLKSWAGEN AUDI

908 S. Northwest Highway (Rte. 14)
Between Lake Cook Roads & Dundee Road
Barrington, Illinois 60010
(847) 304-8822 - 8823

Weekdays 8 AM - 5 PM

Saturday 8 AM - 1 PM



Blackhawk Drivers' Education

FRIDAY *Yes, FRIDAY*, June 11th

Here it is, the first FRIDAY event at Blackhawk. As you know, Blackhawk is a great road course close to home in Rockton, Illinois. **This is our FIRST FRIDAY event - for Experienced & Novice Blackhawk drivers.** Since most Blackhawk events are sell-outs, pre-register as early as possible to assure a spot. Waiting lists will be used to fill any open spots. Cancellations & refunds will be honored until 9 p.m. on the Monday prior to the event.

Mandatory clothing for all drivers at this event includes: a Snell SA 1995 or 2000 Helmet, long sleeve cotton shirt, long pants, socks, all made of non-synthetic materials, and closed toe shoes. Recommended but not mandatory are: driver's suit, driving gloves, driver shoes and a protective neck brace all made of Nomex or similar fire-resistant material, as well as a mounted fire extinguisher. Please check the date on your helmet now, as it will be inspected during the Tech Inspection at the track. **If you and your car do not pass Tech Inspection, you will not be able to drive.** You will be required to show a valid drivers license (no tickets accepted) along with a valid PCA Membership at registration.

You can save time at the track by bringing your car to a recognized Porsche Dealer or Porsche Specialty Shop for mechanical inspection and having them complete, sign and stamp the Chicago Region Tech Inspection Sheet. Review the NEW Updated Year 2004 Tech and Safety Requirements – there are changes from the prior year! Pay particular attention to specifics concerning brake pads and fluid, since Blackhawk Farms is very hard on the brake system!

Blackhawk Concession Stand serves breakfast from 9 a.m. until 10 a.m., lunch from 10 a.m. until 1:30 p.m. The Accessories Store has gas (leaded & unleaded Race only), air, and showers that are open all day.

General Event Schedule:

- 8:00 a.m. - Registration & Tech Open
- 9:00 a.m. - Mandatory Drivers' Meeting
- 4:30 p.m. - Last Car off Track

Contact Event Chairman:

Dan Gallagher (708) 784-0784
Bbabies@aol.com

Directions From Chicago: Take I-90 west to the Rockton Road exit (about 15 miles north of Rockford.) Go west (left turn) on Rockton Road, approximately 5.5 miles and through town of Rockton to Prairie Avenue. Go north (right turn) on Prairie Avenue, approximately 1.5 miles to the track, which will be on your left.

* Mobil station 2 blocks south of Rockton Rd. on Blackhawk Blvd.

First Driver

Year/Car Make/ Model/ Permanent Car Number

Phone

E-mail

(circle ALL applicable) Member Non-Member Guest of: _____

Run Group:

[Instr/Red] [A/Black] [B1/White] [B2/Yellow] [C/Green]

Prior Experience: _____

Second Driver (same car)

Phone

E-mail

(circle ALL applicable) Member Non-Member Guest of: _____

Run Group:

[Instr/Red] [A/Black] [B1/White] [B2/Yellow] [C/Green]

Prior Experience: _____

Pre-registered Entrance Fees received by June 9th, 2004:

Member First Driver - \$160	\$ _____
Family Member-2nd Driver - \$80 *	\$ _____
Non-Member - \$170	\$ _____
Registration received after June 9, or On site registration add \$10	\$ _____
Total	\$ _____

* The \$80 fee only applies to 2nd family member who drives the same car as the first driver. A non-member = \$160

Make check payable to: PCA- Chicago Region

Mail to: Todd Conforti - Blackhawk Drivers' ED Registrar
553 West Carboy Road
Mount Prospect, IL 60056
(847) 382-9656 home (847) 952-0070 work
e-mail: tlcontrols@aol.com

For more information on Track Events, Schedules, Tech & Safety Requirements use the WEB at WWW.PCA-Chicago.org
For more Blackhawk information go to
WWW.namotorsports.com/Tracks/Blackhawk.html.

Tech Quiz

by Mary Anne Nowakowski

Test your knowledge on the following Porsche related questions.

Have Fun!

- 1) What Porsche model was the first one to be marketed with rear tires of larger size than those in front?
 - a) 356
 - b) 911
 - c) 944
 - d) 550/1500RS
- 2) The official driving school of Porsche Cars North America is called?
 - a) The Porsche Cup
 - b) The Driver's Edge
 - c) The Porsche Driving Experience
 - d) Porsche Driving Improvement Program
- 3) PCA's Club Racing program celebrated what anniversary in 2002?
 - a) 10th
 - b) 15th
 - c) 5th
 - d) 1st
- 4) Taking advantage of the shorter overall length of the 4-cylinder engine in the 914/4, the Porsche engineers mounted the engine as far as possible from the fire wall between the engine bay and cockpit, for what reason?
 - a) For safety
 - b) For environmental reasons
 - c) To reduce noise transmitted into the interior
 - d) For future racing considerations
- 5) When initially introduced in 1989, the first production models of the Type 964 (911) were designated as the?
 - a) Carrera 4
 - b) Carrera 2
 - c) Carrera
 - d) Carrera 6
- 6) Which of these Type 964 variants was not available in 1994?
 - a) RS America
 - b) American Roadster
 - c) Turbo
 - d) Speedster
- 7) Towing capacity of 8 cylinder Cayenne models is?
 - a) 6500 pounds
 - b) 15000 pounds
 - c) 7700 pound
 - d) 10000 pounds
- 8) PCM system in the Cayenne controls the?
 - a) Security system
 - b) Engine management system
 - c) Communication system
 - d) Passenger comfort system
- 9) The Porsche GT2 has a center opening at the front edge of the hood that brings air to a heat exchanger and exhausts over the luggage compartment to provide:
 - a) Extra cooling
 - b) Better aerodynamics
 - c) Ventilation for the brakes
 - d) Downforce
- 10) The brake discs on the Type 993 were the first to offer this performance enhancing feature on all road cars?
 - a) ABS
 - b) Powder-coated "Porsche" script
 - c) Mono-block piston calipers
 - d) Cross-drilled rotors front and rear

Answer: 1)d 2)c 3)a 4)c 5)a 6)b 7)c 8)c 9)d 10)d

Want Track Time?

Autobahn Country Club is pleased to announce...

Sold Out

FACT: 40 Founding Members are signed.

Phase 1 Sold Out

FACT: 19 Team unit lots are reserved.

FACT: 50 Country Club Members are signed.

Time is running out. Membership is limited. Pre-construction pricing on Country Club memberships will be limited to 100. After that the initiation fee will be increased.

Your membership entitles you to:

- Unlimited track use
- Limited guest privileges
- Use of the Clubhouse and amenities.

Clubhouse construction will begin after the track becomes operational.

To receive a membership package please call 630 375 7852

www.autobahncountryclub.net



**Scheduled Opening
Mid-Year 2004**



Drive Fast. Be Safe.



In the early **1920's** a group of Shriners from Chicago's Medinah Temple had dream to create a country retreat. Their goal was to build the best country club in North America with a 54-hole golf complex and a variety of other recreational activities. They selected several parcels of land in an area then known as Meacham, in northern DuPage County, which was once owned by the Meacham, Lawrence and Rosenwinkel families.

Tom Bendelow, a world-renowned golf course architect from Scotland, was retained to design the golf courses. In **September of 1925**, the Shriners enjoyed their first round of golf at Medinah. The original Bendelow layout only lasted for three years. A major redesign took place in the early **1930's**.

While the golf courses were being constructed, Richard G. Schmid was hired to plan and design the clubhouse. Schmid had a flair for blending the classic lines of Byzantine, Oriental, Louis XIV, and Italian architecture characteristic of many Masonic structures. His design gave Medinah's clubhouse the taste, style, and elegance still evident today.

Schmid's plans were carefully executed with Schmidt Brothers Construction Company as general contractor. The Schmidt Brothers (Otto, August, and Ernest) were Shriners and charter members of Medinah. The rotunda and murals were the work of another club member, Gustav A. Brand, a German-born artist. Shriners were familiar with Brand's work on the Chicago Medinah Temple and other historic sites.

Winners at Medinah

Since the Medinah Open was played here in 1930, it has been the site of twelve major golf championships. Included among these tournaments were the 1999 PGA Championship, three U. S. Opens, one U.S. Senior Open, and three Western Opens.

There have been many famous past winners at Medinah. **Soon there will be more because ...**



CONCOURS ONE

will be held at

MEDINAH COUNTRY CLUB

on

JUNE 13th

Full details in the May Chicago Scene

Mike and April Milhouse, Co-chairs - 708.92.9623

PHOTO COURTESY OF MEDINAH COUNTRY CLUB

Vehicle Dynamics Workshop

by John Ruther

photos by Steve Rashbaum and Susan Shire

When you dare to do something a little different you usually don't know how well it will turn out. Well, that was certainly the case for the Vehicle Dynamics Workshop. For the past 5 years, Greg Turek and I have been putting on a spring workshop. These originally started out as Instructors Workshops and in the last two years they migrated to sessions designed for racers or those who drive their cars on the track.

This year, we truly had a gift drop into our hands! Susan Shire received a letter from a new Chicago Region member who has been a long-time PCA member in the Lincoln Trails Region, offering to make a series of technical articles he had written available for publication in "The Scene". Well, Susan sent me a copy of his letter and given his credentials Greg and I soon arranged a field trip to Champaign-Urbana for a meeting with Professor Dan Metz.

Dr. Metz has been a Professor of General Engineering at the U of I for 30 years. In addition, during that time he has consulted in the areas of automobile and motorcycle vehicle dynamics and aerodynamics and in accident reconstruction. His clients have included USAC, CART, IRL, FIA, NHRA, the Indianapolis

Motor Speedway, Penske Racing, Team Green Racing, Ferrari, Porsche and many others. During our meeting we were able to convince Dan to be our speaker at a Vehicle Dynamics Workshop for our region and we spent the better part of the day setting the outline for this workshop.

As I said at the outset, we had no clue this event would be so popular and so well received! We had 70

people in attendance for what was a very educational and informative day. That's the good news. The bad news is that we had to turn away approximately 30 people who responded after the event was already sold-out. I guess there are two things we can take from this: first, don't wait to send in your registration, do it as soon as it is announced in "The Scene"; and second, we will try to hold the next one of these spring workshops in a



Greg Turek (left) and John Ruther (right), Event Co-chairs, with Dan Metz



(above) New Chicago Region member Matt Hartsfeld

(right) Some of the 70 participants

room that can handle more people. In any event, those that attended certainly had an opportunity to learn a lot about why their car handles the way it does and if they want to change it – what to do. The morning session was all about Vehicle Dynamics including adjustments of tire pressures, anti-roll bars, springs, shocks etc. Even though this sounds like it might be fairly dry, Dan has enough experience teaching these topics that he's able to make it fun, plus he intersperses the material with lots of great personal experiences and

tidbits he has learned from some of the pro-teams he has worked with.

I'd like to thank Marla Turek who handled all of the food preparations for the day. We had coffee, fruit and pastries for breakfast and a great lunch of lasagna, Italian beef sandwiches, and salad.

After this filling lunch, I'm sure glad we didn't have anyone nodding-off during the afternoon session. This session was all about Data Acquisition: what it does, and doesn't do. There were also

sections showing examples of the traces a system makes and how to "read" them. Some of the examples were actual data from Michael Schumacher and Rubens Barrichello's Ferraris. Much of this info was truly eye opening. And then we had plenty of time for a Q & A session.

I would like to thank Dan Metz for spending the day with our region. I know we are all far better off having had the opportunity of meeting him and hearing some of his insight into what makes our Porsches handle the way they do.



(above) Ted Vaughn (left) and VP Chris Inglot



(above) Director and photographer Steve Rashbaum (left) and Nick Brenkus

Thanks Marla, Greg and John for a day well spent!

(below) Vehicle Dynamics guru, Dan Metz

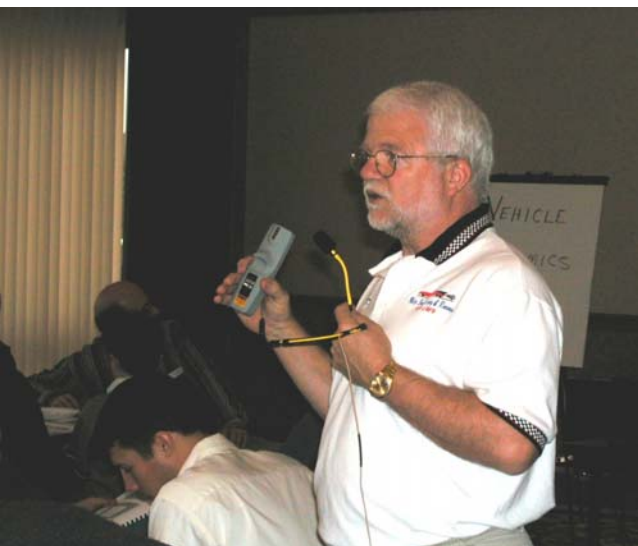

(below) Director Todd Conforti (left) and Jim Hopp





Porsche Cayenne

**The Midwest's Largest Volume Porsche Dealer
Including The Largest Selection of New & Pre-Owned Vehicles.
The Exchange Porsche, where complete satisfaction has been
our commitment to our customers for 27 years!**

RAISE YOUR EXPECTATIONS
THE ♦ EXCHANGE

A Division of Somersky Enterprises Inc.



PORSCHE

**2300 Skokie Valley Rd. • Highland Park • (847) 266-7000 • www.4porsche.com
Monday-Thursday 9a-8p Friday 9a-6p Saturday 9a-5p**



Autocross II

June 27, 2004

PCA CHICAGO REGION

9:00 - 10:00 am	Registration* and Tech
10:15 am	Tech closed
10:15 am	Driver's Meeting
10:30 am	First car off
3:30 pm	Trophy Presentation

Directions to Rockford Speedway:

- From the West: Hwy 20 (bypass) East to Meridian Rd. North 8 miles to Latham Rd. East 8.1 miles to Rockford Speedway.
- From the South: I-39 North to Hwy 20 (bypass)/I-90 West (Madison). Then follow "From the East."
- From the East: I-90 West/North to Riverside Blvd (Exit 66). West 1 mile to Perryville Rd. North 5 miles to Hwy 173. West 1/2 mile to Rockford Speedway.
- From the North: I-90 South to Rockton Rd. West 1 mile to Hwy 251 South. South 6.6 miles to Hwy 173. East 1 mile to Rockford Speedway.

Driver #1	\$35.00 Member	\$40.00 Non-Member Guest - Member MUST be present
Driver #2	\$15.00 Family Member	\$40.00 Non-Member Guest - Member MUST be present
	\$35.00 Member sharing car with other Member	

GENERAL RULES: Required - Snell 1990 helmet, full-length pants, long-sleeved shirts, socks and full shoes. Member may bring one guest. Guest may drive member's Porsche or a two door sports car. Associate Member driving a non-Porsche is considered a Guest. Maximum two drivers per car. Member MUST be present with Guest. Only first car driven will trophy. Valid driver's license at Registration. *On-site registration, checks only, please.

Mail (with check) to: Fred Howard 815.389.1966
 12534 Thistle Ridge Court
 Roscoe, IL 61073

Driver #1 _____ Member Guest*

Phone number _____

Car Model Chicago Region Permanent #

Member Guest*

Driver #2 _____ Phone number _____

Car Model Chicago Region Permanent #

* _____ Total enclosed _____

Guest of Member MUST be present Checks payable to PCA Chicago Region

PCA Chicago Region 2004 Tech Inspection Sheet

NAME: _____ DRIVER CLASS: _____ RUN GROUP: _____

MODEL/YEAR: _____ CAR COLOR: _____ ENG. DISP.: _____ CAR #: _____

Driver Classes: Green (prior C) is slowest, progressing to Yellow (prior B2), White (prior B1), Black (prior A) most experienced and faster. Red may be used as an additional identification for Instructors.

- | Pass | Fail | !!! TO BE INSPECTED BY ENTRANT PRIOR TO EVENT !!! | |
|-------|-------|--|--|
| _____ | _____ | 1. | HELMET, SNELL SA 95 or later required for all Track Events including Blackhawk, Road America, and GingerMan. (Snell SA sticker must be attached inside) |
| _____ | _____ | 1A. | HELMET, SNELL SA or M 90 or later required for all Autocross events Helmet Requirements!
(Snell SA or M sticker must be attached inside). |
| _____ | _____ | 2. | APPAREL - Full-length pants, long sleeved cotton shirts, cotton socks and full coverage shoes are mandatory. Highly recommended, but not mandatory are drivers' suits, driving gloves and shoes all made of Nomex or similar fire-resistant materials. Arm restraints required for All Open Cars. |
| _____ | _____ | 3. | SEAT BELTS - Original factory installed belts for Novice, Green and Yellow.
Required for all other Classes (and all Yellow/White Classes at Road America); <u>Stock Seat = 6-point, "H" Harnesses without Harness Bar & no "H" with Bar or Race Seat = 5/6-Point.</u> All securely anchored, Metal-to-metal, with large diameter washers on both sides of floor mounting holes. Tunnel side belt mounting only on factory seats. Harness and Seats must be equipped the "same" for Driver and Passenger side (Instructor). |
| _____ | _____ | 4. | FIRE EXTINGUISHER - Recommended but not required. Securely anchored metal-to-metal in reach of driver. BC or ABC rated and fully charged. AFFF or Halon recommended. |
| _____ | _____ | 5. | ROLL PROTECTION - Roll Bar, Cage or Extender using "broomstick rule" Required for all A Class. The same Roll Protection is highly recommended although not required for other Classes. Any open car (no roof) must run A Class rules. Cabs must have roof in up position and sunroofs must be closed. |
| _____ | _____ | 6. | PEDALS - Free return and in good operating condition. Firm brake pedal. |
| _____ | _____ | 7. | LOOSE OBJECTS - Remove all loose items from trunk and interior, including glove compartment, door pockets, console, mats, etc. Glove box locked. Spare secured or removed (spare adds to structure to certain Porsches). |
| _____ | _____ | 8. | AIR BAG EQUIPPED CARS - No Obstructions in front of Air Bag (s). |
| _____ | _____ | 9. | WINDSHIELD - No major cracks and functional wipers with good blades. |
| _____ | _____ | 10. | MIRRORS - At least one side (two highly recommended) and one securely mounted rear view mirror. |
| _____ | _____ | 11. | GAS CAP - Gasket intact and cap tightened. |
| _____ | _____ | 12. | RUST - No rust or damage to suspension or chassis parts that affect the integrity of the chassis or brakes. |
| _____ | _____ | 13. | FRONT SUSPENSION - No excessive looseness in steering or suspension. Lower trailing arm to radius tight; Axle and shock bolt tight. Ball joints in good condition. Tie rods secure. Axle boots and oil seals in good condition. Warning: 944/968 MUST Check Ball Joint & Control Arms for cracks and binding caused by excessive lowering, larger sway bars and track usage. |
| _____ | _____ | 14. | REAR SUSPENSION - No excessive looseness. Check half shaft bolts and shock bolts. 914's check fuel pump and lines. No positive camber on any car. |
| _____ | _____ | 15. | WHEEL BEARINGS - Correct adjustment, check for play and proper lubrication, no damaged or burnt bearings. |
| _____ | _____ | 16. | BRAKES - Sufficient brake linings or pads. No rubbing, cuts or abrasions in brake lines. Check rotor condition. Brake pad thickness must be checked periodically for 2mm minimum thickness throughout the high-speed events. Make sure you start with ample brake pad material and/or bring an extra set of pads. It is recommended you start with fresh Competition pads properly bedded in. |
| _____ | _____ | 17. | WHEELS - No cracks. No bends. All lug nuts must have 94 - 96 lbs. torque. Valve stem must have airtight cap. Hubcaps and Center Caps must be removed. |
| _____ | _____ | 18. | TIRES - In Good condition. No cracks or bulges. ZR or better required (HR for Autocross only). Minimum tread depth of 3/32" on contact patch area (race tires or shaved performance tires must have as least 1/16" tread wear marker depth and No Cord Showing). Seek an experienced driver with like car/tires for hot/cold tire pressure. |
| _____ | _____ | 18. | BRAKE FLUID - Level up, must show in reservoir. All cars must have their brake systems flushed with DOT 4 specification or better brake fluid 90 days or less preceding the high-speed event. If another high-speed event is run less than 90 days prior to this event, then the fluid must be flushed again before running. |
| _____ | _____ | 20. | BATTERY (IES) - Securely fastened and in good condition. No acid leaks or corrosion. Check fuel lines under battery trays on 914's. The Positive (+) Terminal on All batteries must be covered by cap or tape. |
| _____ | _____ | 21. | ENGINE - Check for odd sounds and satisfactory exhaust (remember 108db limit at Road America) |
| _____ | _____ | 22. | DRIVE BELTS - Tight and in good condition. |
| _____ | _____ | 23. | LEAKS - No exhaust leaks and leaks of any fluid - oil, gas, brake, or coolant. |
| _____ | _____ | 24. | THROTTLE RETURN - Freely operating and good springs. Check both throttle return springs on CIS cars. |
| _____ | _____ | 25. | BRAKE LIGHTS - All bulbs on both sides and center brake light (if so equipped) must be functional. |

In consideration of my participation in this event, I have checked the above items and certify that they meet or exceed the requirements. I agree to indemnify and hold harmless the organizers of the event, or their agents, with respect to responsibility for the condition and preparation of my car, or any subsequent mechanical failures or resulting damage to my car or its occupants as a result of any such failures. I acknowledge that at all times, I remain solely responsible for the safety and roadworthiness of my car. I hereby certify that I have no physical or mental problems, which could jeopardize any others or myself if I participate in this event.

ALL OF THE ITEMS ON THIS TECH SHEET HAVE BEEN TESTED AND SERVICED AS DESCRIBED. THE TECH INSPECTOR'S SIGNATURE BELOW DOES NOT IMPLY COMPLIANCE WITH THE ABOVE AND IS ONLY AS WITNESS TO THE DRIVER'S SIGNATURE, WHICH WARRANTS COMPLIANCE.

DRIVER'S SIGNATURE: _____ DATE: _____

WITNESS TO DRIVER'S SIGNATURE (Inspector): _____ SERVICE STAMP _____ DATE: _____

Oversteer

From the Internet

Conversions Made Easy

For those who thought the hardest part of Physics 101 was the constant conversion from MKS or CGS units to English units, here are some useful English system conversions.

- * Ratio of an igloo's circumference to its diameter: Eskimo Pi
- * 2000 pounds of Chinese Soup: Won ton
- * 1 millionth of a mouthwash: 1 microscope
- * Time between slipping on a peel and smacking the pavement: 1 banana second
- * Weight an evangelist carries with God: 1 billigram
- * Time it takes to sail 220 yards at 1 nautical mile per hour: Knot-furlong
- * 365.25 days of drinking low-calorie beer because it's less filling: 1 lite year
- * Half of a large intestine: 1 semicolon
- * 1,000,000 aches: 1 megahurtz
- * Basic unit of laryngitis: 1 hoarsepower
- * Shortest distance between two jokes: A straight line (Think about it)
- * 453.6 graham crackers: 1 pound cake
- * 1 million microphones: 1 megaphone
- * 2 million bicycles: 2 megacycles

- * 365.25 days: 1 unicycle
- * 2000 mockingbirds: two kilo mocking birds (work on it...)
- * 10 cards: 1 decacards
- * 1 kilogram of falling figs: 1 Fig Newton
- * 1000 grams of wet socks: 1 literhosen
- * 1 millionth of a fish: 1 microfiche
- * 1 trillion pins: 1 terrapin
- * 10 rations: 1 decoration
- * 100 rations: 1 C-ration
- * 2 monograms: 1 diagram
- * 8 nickels: 2 paradigms
- * 2.4 statute miles of intravenous surgical tubing at Yale University Hospital: 1 I.V. League

For those of us who have been infected by some bug or other lately, here's some PAYBACK!

The Top 9 Kitchen Fixes for Computer Glitches

9. Bugs go well with a nice Shiraz or marinated in a vintage tequila. It may not fix the blasted computer, but after a few bottles, you won't care and they'll certainly not be bothering you anymore!
8. If you receive a kernel.dll error, place affected kernel in corn oil

and cook until all popping sounds have stopped.

7. Toss chips with spaghetti-wires, sauté until logic fails.
6. Show the computer canned SPAM. Explain this is what happened to a pig with a glitch. The computer should straighten right up.
5. Some problems are a result of the computer overheating. Keep a few frosted memory chips and cards in the freezer for those warm days.
4. Stuff in the oven and bake at 450 degree for 30 minutes. For higher altitudes, reduce free memory by 500 MB and allow ten extra minutes.

3. Preheat oven to 350 degrees. Place computer on a lined jelly roll pan. Bake about 20 minutes, or until the DVD-ROM drawer pops open and the computer waves a tiny little white hot pad, indicating it's now willing to comply. Remove from the oven, being careful not to burn yourself on the molten plastic. Cool to room temperature. Call customer support for shipping instructions.

2. Crack open case with one sharp blow and flip the memory from one half to the other, allowing the RAM to fall into your mixing bowl while keeping the ROM in the shell.

... and the #1 Kitchen Fix for Computer Glitches ...

1. Cook at 11111010 degrees for 101101 minutes, or until a very golden brown.

FOREST AWARDS & ENGRAVING

336 E. IRVING PARK RD. • WOOD DALE IL 60191

WWW.FORESTAWARDS.COM

SUPPLYING THE CHICAGO REGION PORSCHE CLUB
WITH TROPHIES & AWARDS FOR OVER 10 YEARS
ALONG WITH AWARD WINNING CUSTOMER SERVICE

CONTACT NICK BRENKUS (PCA MEMBER SINCE 1978)

FOR ALL YOUR CLUB & CORPORATE EVENT AWARDS

847-426-9199

The Mart

PCA members are welcome to place ads of a non-commercial nature at no charge in **The Mart**. The non-member, non-refundable fee for this service is \$15.00 for three months, and checks should be made payable to **PCA Chicago Region**. Ad material must be received by the 1st of the month for publication in the next month's issue, is subject to editing, and will run for three months. To be run again, after the initial three month period, ads must be resubmitted. Please limit ads to 75 words or less. Please see page 1 for submission information.

The Mart/Chicago Scene
Susan Shire
1897 Mission Hills Lane
Northbrook, IL 60062

Phone: 847.272.7764
Fax: 847.272.7785
e-mail: ChiScene@aol.com

For Sale



PORSCHEs

1976 Porsche Turbo Carrera (930) Black/Tan; very nice/clean; no accidents/maintained with open checkbook; \$22K+ invested in re-conditioning/mechanical upgrades/too many to mention; all records available. Asking \$20,500. John Olson, Omaha, NE, (w) 402-330-1010, (h) 402-392-2781 (AMJ)

1982 924 Track Car - upgraded brakes to 944 4-wheel disc/ Audi trans. Call Andy @ 309-370-3204

1987 911 Carrera Coupe Guards Red/black; 55K mi; sunroof; F & R adj sway bars; Bilstein coil-overs; turbo tie rods; strut brace; Boxster front calipers; F & R cross-drilled rotors; front brake cooling ducts; SS

brake lines; original 16" Fuchs w/ Guards Red spokes; DAS Sport roll bar; Auto authority mass flow induction; catalyst bypass; AC; Pioneer AM/FM/CD; bra & cover; new turbo clutch and top-end job @ 52k (due to valve guides); documentation of all service. \$29,500/OBO. Bill 217-872-6929 wframe67@hotmail.com (AMJ)



1988 911 Targa Casis Red/maroon Leather; exc cond; 83,xxx mi; 2nd owner; purchased July '99 w/75,xxx miles; always garaged; non-smoker; only driven in nice weather; pampered; 16" Fuchs w/like new Pirelli P7000 Sports- 225 front/245 rear; new Optima battery conversion; recent brakes; new alternator; axle boots; K&N filter; engine is dry; will include car cover/bra; stands out from others at \$23,000!! Keith Jahn keith.w.jahn@saint-gobain.com (773)338-0735 pics available (MAM)

1988 911 Cabriolet Black/maroon; 49,750 miles; concours ready; Weidman polished OEM rims/Yoko AVS tires like new; all new Auto Authority chip/K&N air filter; Boge shocks; sway bar bushings & rear linkages; Blaupunkt CD stereo/speakers; 12-way drivers seat/8-way passenger seat; Momo steering wheel; bra; factory window seals/horizontal & vertical; A/C recently serviced; rear window is clear; top exc cond; leather soft/scratch free; car needs nothing! \$38,000.00 invested/\$32,000/OBO, Dave Leger, 630-669-1979, drddl1@covad.net [AMJ]

1989 911 Coupe Black/cashmere; 127,000 mi; WPOAB0914KS120160; Factory tail/front spoiler/power

windows/sunroof; reliable everyday driver; exc cond inside/out; maintained by Midwest Eurosport; never tracked; engine needs work; photos available via email. \$8,500. 312-252-1401 (AMJ)

1997 911 Turbo Arena Red/gray leather; Carbon Fiber Package/incl steering wheel/alum dials; 23K mi; premium sound w/CD; heated seats w/crest; 6 speed; B&B exhaust; 18" 996 Factory turbo wheels; exc cond, \$80,000 630.865.4357 Tony (AMJ)

1990 911 Wide body C4 Black on black; very rare; totally redone top to bottom - looks like new; many new parts; looks fabulous; 2,200 mi on rebuilt motor; new 18: wheels/tires \$39,000 invested - asking \$25,000; will sell fast. JR, 708.257.8098. (MAM)

1999 996/911 Coupe Dark blue; 6 speed; 22,000 miles; clean/fast; never raced/rallied; minimal frou-frou; No Smoke(In or out); Options - M030/M436/P72/P77/B-K harness bar with belts; Priced to Sell at \$46,525; Includes **FREE** Winter Snow Machine: 1996 Jeep, good runner; with spares. B. Janecek janecechmate@aol.com (MAM)

2000 Boxster Triple Black 15,000 mi; 18" Wheels; Sport Package/Interior; Traction control; manual; in-dash CD; WPOCAZ981YU622202; exc cond. \$32,5000 Greg Karr, 630-513-1681, gmkarr431@aol.com (MAM)

2002 Boxster S Artic Silver/Black; 18,000 mi; Raised in the south/ garage kept; heated seats; sport pkg; PSM; New job/company car leaves little time for fun; \$42,000. 910-988-3936 (jjaneski@aloka.com) (AMJ)

TIRES/PARTS/MISC

944 Turbo S rims with tires One set, chromed with painted center caps on Dunlap Sport 9000 225/50ZR16,

245/45ZR16; \$3,000 new from Wheel Enhancement/as new condition, \$2,000. Tom, 847.909.8460, tkowalski@mwenv.com [FMA]
Wheel (1) 8.5 x 16 OEM Slot Disk (Manhole Cover) rim in good condition. \$60 Tom, 847.909.8460, tkowalski@mwenv.com [FMA]

BBS Wheels with tires very good cond w/Bridgestone (f) 205/55/ZR16, (r) (245/45/2R16; full polish; center caps. Make an offer. John (w) 847.630.2037, (h) 847.541.3616. (AMJ)

Parts Complete interior from 1986 951; all black/full leather in almost perf cond/no crack/as original; front seats (driver's electric sport/passenger manual); dash w/gauges; console; rear seats; door panels/windows & hardware; sun roof w/ actuator & trim. Need anything? Tim (h) 847.223.1221, (w) 847.548.1080, trw@pwpinc.com (FMA)

Parts Rocker deco trim w/end caps, rubber inserts, plugs and mounting hardware. Also rear Porsche center

reflector with mounting panel - fit either 1978-89 Porsche 911 or 1974-1975 Carrera. If interested call Chuck Marsicek at (630) 682-9326 or (708) 502-5537 (MAM)

1977 - 924 rolling chassis. Spare engines, trans, brakes, shocks, springs, interior parts, trim, seats and other assorted parts; MANY, MANY sets of 4-bolt 14" + 15" rims and 5-bolt 15" "Cookie Cutter" rims; bolt in cage; front and rear strut bar. Make an offer for some or all. Call Andy @ 309-370-3204 (AMJ)

OTHER

1987 BMW 325iC Convertible, 2.5l straight 6; red w/black leather interior, exc cond; new black soft top; major Bilstein/Koni suspension upgrades professionally installed by Midwest Eurosport; BBS RS rims; new clutch/starter/rotors/etc; high end Sony stereo/CD changer; stored winters; classic BMW style; 198K mi. Too many cars! Asking \$4500 to good

home. Michael 312.943.8369 (AMJ)
Wheels & tires BMW 1993 3 Series 18 spoke wheels 7x5 w/Yokohama 205/60/15 tires & center caps. BMW 1992 5 Series 20 spoke wheels w/ Goodyear 205/60/15 tires & center caps. Mercedes Benz old-style alloys w/caps & 205/70/14 Michelin tires. Wheel & tire packages \$200 each or all three for \$550. Brian Stein 630.469.5979 (MAM)

For Rent

For Rent: Galena/Eagle Ridge Getaway 4 BR Home 4 1/2 BA, 2 FP, 3 TV (1 plasma) w/DVDs; 3 golf courses, bucolic countryside. Chicago PCA member - for details, 1-800-892-2269, (unit #610) (MAM)

Wanted

2004 January and 2004 February Chicago Scene issues in good condition; Susan 847.272.7764



Aungahh!

Now I know that we're all busy ... what with jobs (boo), families, and all of those other things that take up our precious time. *Come on.* As an added incentive, if you're at an event and someone is taking pictures, you just might end up with your picture or one of *your baby* in the Chicago Scene. I don't know about you, but I'd like to see some different faces and cars on these pages.

Thank you to all that have let me know how much you like what we're doing with the Chicago Scene. It is for me, in case you haven't guessed, a true labor of love. I am lucky to have so much help (check out the number of people listed on page 1 who contributed to this issue) as well as the unsolicited offers to write articles and take pictures. And then there are those of you who have not refused to write articles and take pictures when begged. Please know that I, as well as the rest of the membership, appreciate your contributions.

Speaking of labors, there have been and are planned, some really fine events for all of you by some of our members. It is disappointing to have spent the hours of work required to put on events and only have a few of our 1300 plus members show up.

On the subject of doing different things with our precious time, how about a round of applause for busy members (recent Region President) Susan Brenkus and Pat Yanahan, who found the time and, more importantly, the inclination and dedication to compete in the annual Chicago Athletic Association Mini-Triathlon. The event requires contestants to swim 1/2 mile, bike 10 miles, and run 3 miles ... I get tired just keyboarding it! Both Susan and Pat won first place in their age divisions. Susan's husband, Nick, has just perfected and sent an entry to the Pillsbury Bake-Off. Elsewhere in this issue you will see what else Pat has been up to.

Now, are you really too busy to get out to an event where you can enjoy your car and the other Club members? There's got to be *one*

event, of all those advertised in this issue, that can get you involved. In this issue alone there are announcements for 13 events ... and that's just for April, May and June!.

For those of you that missed the Vehicle Dynamics Workshop, you missed a truly wonderful day. Dan Metz, as John Ruther will tell you elsewhere in this issue, is a most informative and entertaining speaker. His stories were terrific and even I understood much of the technical stuff. We owe Greg and Marla Turek and John Ruther an "Attaboy/girl" for their efforts to make that tech session possible ... another labor of love?

I have received several pictures for consideration as future Chicago Scene covers. Thank you. The best pictures for covers are those in Portrait Orientation and high digital resolution. Please include your name as well car and picture locale information.

Finally, this is *your* Club. If you have an idea for an event, let someone know ... Jim Jacisin ... a Board Member ... me. One of the reasons that the Board Members have a page with their pictures is so that, hopefully, you'll feel comfortable approaching and talking to them ... after you've looked at their 'mugs' month after month. If you want to be more involved, speak up ... believe me, we've got fun stuff for you to do!

So, register for Parade, find an event or two that looks interesting, and get your car out of storage. The birds are returning, the bulbs are popping through the mulch ... Spring is here!

There's lots to do. We'll see you at an event soon!

SUSAN



Congratulations to Susan Brenkus and Pat Yanahan

photo submitted by Pat Yanahan

Aungahh (a-uun-gaaa), n. [Skip Barber Racing School]. 1 The sound of the motor of a car as the clutch is depressed, the brakes applied, and the throttle "blipped" to effect a heel and toe downshift. 2 Editors' column.

Why Would You Ever Consider A Luxurious PreOwned Vehicle From
Napleton Porsche in Westmont?

The Answer Is Quite Simple...



***It's All About
Selection.***

***The Midwest's Largest Exclusive Porsche Dealer
Finest Selection Of New And Preowned Porsches In The Midwest!***



NAPLETON
PORSCHE

201 E. Ogden Ave. • Westmont, IL • 630-725-0911 • www.ednapleton-porsche.com

Enjoy the races, visit us in Chicago!

BELLA BACINO'S

Ristorante & Pizzeria

featuring ANDRETTI WINES



- CREATIVE ITALIAN CUISINE
- FRESH SEAFOOD SPECIALS
- HOMEMADE BREADS & DESSERTS
- WINNER: AOL PIZZA POLL
- OUTDOOR CAFE SEATING
- RELAXED ATMOSPHERE
- FRIENDLY PEOPLE

WINE SPECTATOR AWARD OF EXCELLENCE

36 S. LaGrange Rd., LaGrange, IL. *** 75 E. Wacker Dr., Chicago

CHICAGO SCENE

838 Lee Street
DesPlaines IL 60018-0545