

THE OFFICIAL PUBLICATION OF THE PORSCHE CLUB OF AMERICA - CHICAGO REGION

Chicago Scene

JUNE 2004



PHOTO RALLYE

GINGERMAN DE REGISTRATION FORM

AUTOCROSS SCHOOL

TRAC 2004 REGISTRATION INFORMATION

50 YEARS OF PORSCHE ... THEN AND NOW

Chicago Scene



Departments

- 28 Address Change Form
- 72 Aungahh!
- 23 The Bulletin Board
- 2 2004 Calendar / Three Months At A Glance
- 11 Charity Scene
- 8 Club Racing Scene
- 67 Chicago Region 2004 Tech Inspection Form
- 30 The Goodie Store
- 70 Index of Advertisers
- 4 It's Why You Bought The Car
- 69 The Mart
- 18 Membership News
- 3 Officers, Directors & Coordinators
- 68 Oversteer
- 47 Q & A
- 25 Q-tip Corner
- 14 Rallye Scene
- 52 Technical Scene
- 43 Tech Quiz

June 2004 Features

- 21 2004 DE Events
- 32 Autocross In A BMWX-3
- 26 The Autocross School
- 38 50 Years Of Porsche ... Then & Now
- 55 The Midship Report: Spring Tuneup
- 49 Places To Stay While Visiting GingerMan Raceway
- 63 Places To Stay While Visiting Road America
- 15 Time For The Real Thing
- 60 TRAC 2004 Event Information

Event Announcements

- 29 Autocross II - Jun 27th - Rockford Speedway
- 31 Autocross III - Jul 18th - MGA Proving Grounds
- 59 Autocross IV - Aug 22nd - Lake Geneva Raceway
- 22 Blackhawk DE - Jun 11th
- 33 Blackhawk DE - Jul 23rd
- 54 Blackhawk DE - Aug 18th
- 24 Concours I - Jun 13th - Medinah Country Club
- 35 Concours II - Jul 25th - Potter's Picnic
- 45 Concours III - Aug 1st - Cuneo Classic
- 64 Concours IV at TRAC 2004 - Sep 4th
- 48 GingerMan DE - Aug 7th - 8th
- 41 Golf Outing and Dinner - Jul 31st
- 7 Kane County Cougars Baseball Game - Jun 5th
- 35 Potter's Picnic - Jul 25th
- 13 Rallye II - Jun 6th - Do We or Don't We ... ?
- 51 Rallye III - Aug 15th - Drive Around ...
- 61 TRAC 2004 DE - Sep 3 - 6
- 65 TRAC 2004 Club Race - Sep 3 - 6



With the storm on the horizon, Tom and Phyllis Harwood's 1979 911 SC

photo by Jim Jacisin

Contributing to this issue: Jim Jacisin, Russ Pesko, Dan Metz, Steve Rashbaum, Mike Rende, Ed and Debby Leed, Gene Bussian, Van Larson, Steve Grosekemper, Van Miller, Nadine Haupt, Chris Inglot, Jim Drury, John Mueller, Mary Anne Nowakowski, John Ruther, John Miller

The **Chicago Scene** (ISSN 10564195) (USPS 0006-381) is the monthly publication of the Porsche Club of America (PCA) - Chicago Region, printed at PressTech, 959 Lee Street, Des Plaines, IL 60016-6545. Periodic Rate Postage paid at Des Plaines, IL USPS Subscription is provided to members of the PCA - Chicago Region. PCA dues are \$42.00 annually, of which \$12.00 is for the subscription. Subscription rate for non-Chicago Region members is \$24.00 per year. Permission to reprint any material published herein is granted, provided full credit given to **Chicago Scene** and the author. PCA - Chicago Region is not responsible for any services or products advertised herein. Statements appearing in the **Chicago Scene** are those of author and do not constitute an opinion of the PCA - Chicago Region or its Board of Directors.

All copy material must be received by the 1st of the month for publication in the next month's issue and will be published on a space available basis. The editor reserve the right to edit all materials submitted for publication.

Articles are preferred in MSWord. Do not send articles in pdf format. All digital photos should be taken at the maximum resolution the camera allows (minimum 300 dpi). File format may be tiff or jpeg.

Commercial Advertising Rates (per issue/billed quarterly)
Business card: \$75.00 One-quarter page: \$175.00
Half-page: \$250.00 Full page: \$450.00
Cover: not currently available

Susan Shire
Editor/Advertising Manager
ChiScene@aol.com
847.272.7764
Fax 847.272.7785
1897 Mission Hills Lane
Northbrook, IL 60062-5760

Send address changes to:
Postmaster
Bob Soske
PressTech
959 Lee Street
Des Plaines, IL 60016-6545
e-mail: Leedlast@hotmail.com

THREE MONTHS AT A GLANCE

2004 Calendar (as of 3/15/04)

Italics = info in this issue CAPS = change

Sun	Mon	Tue	Wed	Thu	Fri	Sat
	June 2004				4 BOARD MEETING	5 KANE COUNTY COUGARS GAME
6 RALLYE II					11 BLACKHAWK DE	
13 CONCOURS I						
20						
27 AUTOCROSS II						
July 2004						
				1	2 SEM GingerMan DE & Club	3
4  Gingerman Club Race			7 PORSHE PARADE in Fort Worth, TX	8	9 BOARD MEETING	10
11						
18 AUTOCROSS III					23 BLACKHAWK DE	24
25 POTTER'S PICNIC/ CONCOURS II						31 GOLF OUTING
1 CONCOURS III - CUNEO CLASSIC						7 GINGERMAN DE
8 GINGERMAN DE					13 BOARD MEETING	14
15 RALLYE IV			18 BLACKHAWK DE			
22 AUTOCROSS IV						
29				Aug 2004		

Jun

- 5 Kane County Cougars Game
- 6 Rallye II
- 11 Blackhawk DE
- 13 Concours I
- 27 Autocross II - Rockford Speedway

Jul

- 4-10 Porsche Parade
- 18 Autocross III - MGA
- 23 Blackhawk DE
- 25 Potter's Picnic/Concours II
- 31 Golf Outing

Aug

- 1 Cuneo Concours III
- 7-8 GingerMan DE
- 15 Rallye III
- 18 Blackhawk DE
- 22 Autocross IV - Lake Geneva

Sep

- 3-6 TRAC 2004 DE & Club Race
- 4 TRAC 2004 Concours IV
- 5 TRAC 2004 Dinner & Party
- 12 Rallye IV
- 15 Blackhawk DE
- 19 Autocross V - Maywood Park
- 26 Concours V & Charity Event

Oct

- 2-3 Blawkhawk Octoberfest DE
- 16-17 Rallye V
- 23 Concours Judge's School
- 24 Weber Grill Social/Bears Game

Nov

- 6-7 Driving Tour in MI
- 14 Tech Session

Dec

- 11 Dinner Dance

2004 CHICAGO REGION OFFICERS AND BOARD OF DIRECTORS



President
Jim Jacisin
630.279.4835 (h)
630.665.3491 (f)
james@design-dept.com



Vice President
Chris Inglot
847.559.1126 (h)
773.286.4811 (f)
CInglot@aol.com



Secretary
Ed Barnicle
630.323.2963 (w)
630.323.5334 (f)
ebarnicle@dolphincartage.com



Treasurer
Jack Stephensen
708.492.0160 (v)
847.541.6171 (f)
jstephensen@aol.com



Past President
Keith Clark
630.690.3381 (h)
630.690.3394 (f)
ClarkFNFlying@aol.com



Director
Todd Conforti
847.952.0070 (w)
847.952.1261 (f)
tlcontrols@aol.com



Director
Pete Hackenson
630.655.1629 (h)
630.655.4841 (f)
P.Hackenson@comcast.net



Director
Mary Anne Nowakowski
847.929.1831 (w)
847.470.1204 (f)
nowakowskim@permapipe.com



Director
Ken Pesavento
630.469.1546 (v)
Kenneth_a_Pesavento@ml.com



Director
Steve Rashbaum
847.272.7731 (h)
847.272.7785 (f)
SRashbaum@Invitrogen.com

2004 COORDINATORS

Autocross - Jeff Girard

815.838.3000
dukiemaxgirard@aol.com

Autocross Tech/Registration - Mike Hill

708.415.0769
michael@mphproductions.com

Charity - Jim Drury

708.354.8121
JamesDrury@ameritech.net

Chicago Scene - Susan Shire

847.272.7764
ChiScene@aol.com

Chief Driving Instructor - John Ruther

847.304.5515
chief_instructor@pca-chicago.org

Concours - Van Larson

630.377.4686
Valyr9090@aol.com

Concours - A J Tiller

312.735.8771
aj2manycars@aol.com

Database - Ed & Debby Leed

847.382.6911
leedlast@hotmail.com

Blackhawk DE - Dan Gallagher

708.784.0784
bbabies@aol.com

Blackhawk DE - Pete Hackenson

630.655.1629
P.Hackenson@comcast.net

Gingerman DE - Jeff Girard

815.838.3000
dukiemaxgirard@aol.com

RADE 2004 - Pete Hackenson

630.655.1629
P.Hackenson@comcast.net

RADE 2004 - Keith Clark

630.690.3381
ClarkFNFlying@aol.com

DE Tech - Toby Duckett

630.248.7680
toby@mc2fyi.com

DE/TRAC Reservations - Nick Brenkus

847.426.9111
nsbrenkus@prodigy.net

Goody Store - Chuck LaMantia

630.510.7418
claman1022@msn.com

Goodie Store - Keith Clark

630.690.3381
ClarkFNFlying@aol.com

Historian - John O'Keefe

708.531.9116
jdok911@aol.com

Insurance - Keith Clark

630.690.3381
ClarkFNFlying@aol.com

Membership - Van Miller

847.949.0972
Quik550@aol.com

Novice Driving Instructor - Ed Leed

847.382.6911
leedlast@hotmail.com

Photography - Steve Rashbaum

847.272.7731
porsche575@comcast.net

Property - Ed Leed

847.382.6911
leedlast@hotmail.com

Rallye - Tom & Phyllis Harwood

847.742.6804
TRH911sc@aol.com

Rallye - Ken Pesavento

630.469.1546
Kenneth_a_Pesavento@ml.com

Safety - Todd Conforti

847.952.0070
tlcontrols@aol.com

Social - Chuck & Melissa LaMantia

630.510.7418
claman1022@msn.com

Timing & Scoring - Chuck Bittman

708.352.9505
cbittman@bellebotanicals.com

Timing & Scoring - George Schaefer III

708.562.5908
Georgetheiii@bureauhq.com

TRAC 2004 - Pete Hackenson

630.655.1629
P.Hackenson@comcast.net

TRAC 2004 - Keith Clark

630.690.3381
ClarkFNFlying@aol.com

TRAC 2004 Race Tech - Todd Conforti

847.952.0070
tlcontrols@aol.com

Webmaster - Greg Gulik

312.642.5377
webmaster@pca-chicago.org

Zone 13 PCA Rep - Butch Raiha

217.877.6874
raiha@aol.com

No phone calls or faxes after 9:00 pm, please

It's Why You Bought The Car

by Jim Jacisin, President

Blame It On A Corvair

Remember your first childhood automotive memory? Mine is in an air-cooled 6-cylinder rear engine car. It was red. It was a time before my sister was born, an era known as BC (*before Cindy*) followed by AC (*after Cindy*). During the AC period, my father moved us into the turbo charged version. Both were Chevrolet Corvairs.

The point is, very few of us are born into these cars. Somewhere along the line we made the choice to make these tools a part of our lives. While growing up I saw the 911's. A friend's father even had one that I saw every day on my way to grade school. It was a '73 tangerine Targa. Cool car! ... at the time, I never thought I'd own one. I always considered my young self a Ferrari guy. Front engine, long hood, short deck.

So what led me down the Porsche path? ... Indy Car racing at Elkhart Lake. One of the support races featured the Porsche 951's aka 944 Turbos. It was love at first sight.



Jim Jacisin at the Autocross School where it threatened to rain, but never really did.

photo by Chris Inglot

Off to the dealer I went to take delivery of a brand new 944, which led me to fall in love again with a 944S2 Cabrio that Patty and I still own.

Is there a point here? ... stay with me.

No matter how fast or capable or even financially successful these cars were, bringing one to a typical PCA event was met with, "Thanks for coming, why don't you park in the back ... way back". That's where I met Past President Keith Clark, Autocross Chair Jeff Girard, Rallyist Extraordinaires Chuck Bittman and Lee Lichtenstein, Concours Guru Rich Laurie, Uber Racers Nick & Susan Brenkus with Greg and Marla Turek, Mr. Road America Chris Inglot, and Drivers- Rallyists- Photographers-Editors Steve Rashbaum and Susan Shire. All drivers of cars with the engines on the wrong ends and water, not air, pumping through its veins. A lot of good friends driving cars that most purists simply didn't like.

Which leads me (finally) to this very long, drawn out point ... where are the Cayennes?

I know that they are out there. And, more than a fair share are owned by our own new and old members alike. They are as welcome and as capable as any other vehicle that wears the Porsche crest. Here's the deal. Concours and Rallye season is here. Bring the Cayenne and the event is on us. We won't even make you park in the back. In a year or two, maybe you'll be writing this column.

Looking forward ...

June. We wait all year for June. Can you believe that with this issue we are half way around our annual lap of the sun? I wish June could go on forever. The long daylight hours are here. Half way home and it's

finally Concours season. Our first Concours this year is at a brand new venue, Medinah Country Club, along with a brand new Event Chair, our tennis pro and former 951 driver, Mike Milhouse. You will find a class for everyone in Concours, from a simple 'give the car a bath' to detailing the underside. At worst what you will walk away with is a clean car. The most important part is that you are there.

As of this writing, the jury is still out on if my Boxster was out of foul ball range at the Kane County Cougars game. If you see our Goodie Store Chair, Chuck Lamantia, at Medinah, you know the answer. And with a midweek Blackhawk just days before, you know he was quite busy cleaning.

The next day brings us the 'Do We or Don't We Stop Cemetery' Rallye. I might be early, I might be late, but trust me, I'm not stopping. I don't even want to know how Ken and Nikki Pesavento dreamed up this one.

And finally we finish June with Autocross 2 at the 'highbanks' of Rockford Speedway. Give Fred Howard an envelope with your registration. This promises to be another quick, fun and safe autocross.

Looking back ...

May was busy. Very busy. We started with Blackhawks One and Two, Experienced and Novice Driver days, which feature our talented driving instructor group who give up large parts of their day to pass on their insights and passion. Thanks Pete Hackenson. Thanks Dan Gallagher, who has been doing this even before I was even eyeing that '73 tangerine targa.

Send a note to Nick Brenkus and John Ruther, and Auctioneer James Drury for hosting our swap meet

and car parts/stuff auction. Finally we all have some breathing room.

Autocross One was next. It was at the same site as the Autocross School. Give Jeff Girard (& Max) a pat on the back for not only being the Autocross Coordinator, but for chairing the region's first for-points autocross. And thanks to all the autocrossers for resetting (and resetting again) the cones after I knocked so many of them down.

And yes, Road America (RADE) on Memorial Day. Congratulations to Keith Clark and Pete Hackenson for again chairing this event. It is

nearly impossible to thank and congratulate everyone it takes to put this together. From Tech to Registration, great job everyone. Thank you. I cannot wait for Labor Day, and neither should you.

Some personal stuff ...

We bid farewell to our Chicago Region Photographer, Russ Pesko, who leaves for greener (?) pastures in Boston. Being the photographer is like being the new guy on Star Trek. If you're looking for a job, take this one. First Paul Silver, now Russ. Steve Rashbaum will take command. Hold on to your resume.

Congratulations to club members (and former Scene Editors several times) David & Heather O'Brien for another addition with the arrival of Baby Emily. Perhaps David will need a Cayenne. Congratulations (again) to happy grandparents Ed and Gayle Barnicle on the arrival of Ryan Edward Barnicle.

And finally, tell my Mom happy birthday (June 1). She really liked that Corvair.

The days are long, the sun is warm. It's time ... get out there.



R & W
PERFORMANCE
PARTS-ACCESSORIES-TOOLS

Full line of performance parts, OEM parts, and tools for Porsche. Shop our growing online catalog. If your part isn't online yet, contact us for availability and pricing. We specialize in providing low prices for your entire project list - send a list for your quote.

RWPARTS.COM

ITALY 2615 Rutland Rd.,
Naperville, IL 60564
630-841-2959

PERFORMANCE FRICTION BRAKES

R.A. Adams
ENTERPRISES, INC.

- TRAILERS • HITCHES •
- TRUCK EQUIPMENT •
- Full Service / Electrical
- Custom Paint / Graphics
- Full Line of Accessories

2600 W. RTE. 120, MCHENRY, IL
(34 MILE EAST OF FOX RIVER)

(815) 385-2600
www.raadams.com

OPEN: MON-FRI 7:00 - 5:30
SATURDAY 7:00 - 1:00

- OVER 400 TRAILERS IN STOCK •
- FINANCING & NATIONWIDE DELIVERY AVAILABLE •
- FAMILY OWNED & OPERATED FOR OVER 45 YEARS •

DESI VINCZEN
BOB VINCZEN

Body Works of Barrington
SPECIALIZING IN MERCEDES, PORSCHE AND B.M.W.
ALL IMPORTED SPORTS CARS

126 N. COOK STREET PH 847.381.9144
BARRINGTON, ILLINOIS 60010 FAX 847.381.9163

EUROSPORT *Racing*



996 & Boxster Servicing & Performance Upgrades

WE SPECIALIZE IN SERVICING ALL OF YOUR PORSCHE STREET, TRACK & RACE CARS.

Mid-Ohio Novice Racer of the Event - John Mueller



BOSCH MOTEC Systems Hoosier Tires JRZ Shocks Fikse Wheels Recaro Seats



- Street, Autocross & Race Car Prep
- Engine Development & Dyno Testing
- Performance Modifications & Tuning
- Alignment & Corner Balancing
- Custom Exhaust & Tuning
- Transport & Support for Driver's Ed & Club Racing Events
- MOTEC Fuel Injection & Data Logging

**PORSCHE :SERVICE
:PARTS
:ROAD RACING**

**BOSCH :ELECTRICAL
:BRAKES / ABS
:FUEL SYSTEMS**

WWW.MIDWESTEUROSPORT.COM

**104 W. IRVING PARK RD. BENSENVILLE, IL 60106
PHONE: 630-595-5577 FAX: 630-595-8096**

Porsche Club of America - Chicago Region Social Event

For the entire family and invite your friends!



and the Kane County Cougars Versus West Michigan White Caps (Detroit Tigers)

POSCHE CLUB OF AMERICA

Saturday, June 5, 2004

Game time 6:00 PM

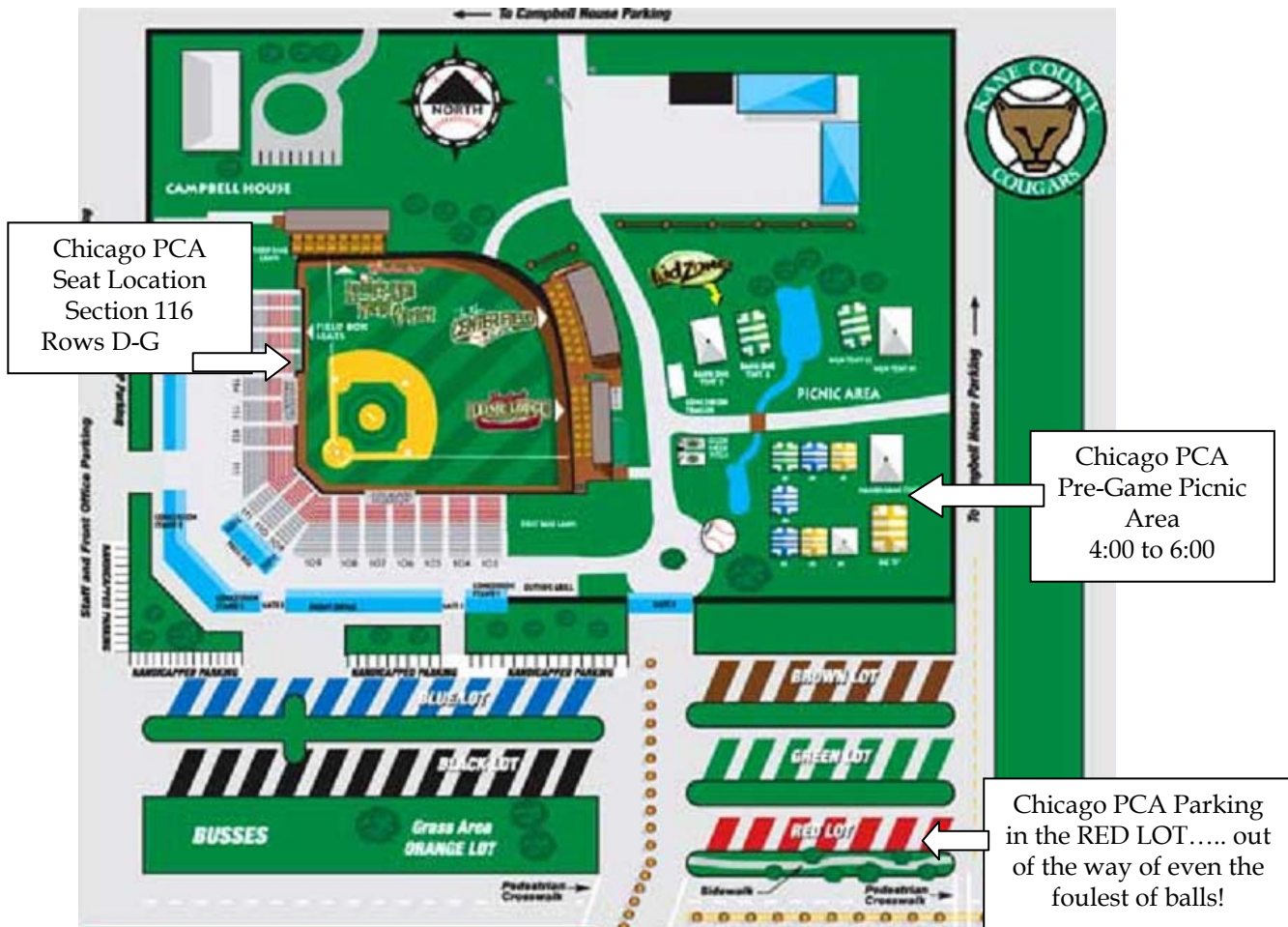

- Great up close box seat.
- Pre game food starting at 4:00pm.
- Soda included for the entire game.
- Fantastic post game fire works display.
- Kids of all ages from 1 to 101 get to run the bases after the game!

Special Porsche / paved preferred parking for only \$2.00 per car.

SPACE IS LIMITED. RESERVE YOUR SEATS TODAY!

ONLY \$25.00 per PERSON

Chuck and Melissa LaMantia (630.510.7418) or Keith and Karen Clark (630.690.3381)
Contact info for SOCIAL available in the Scene or www.pca-chicago.org under CONTACTS.

Club Racing Scene

PCA Club Racing - Too Many People to Thank

by John Mueller

I have just completed my first two PCA Club Races and I find myself with too many people to thank. First and foremost must be my wife, Pat, who gave me the green light to go racing and the five hundred-dollar gift certificate to Eurosport that she won at the dinner dance.

Some Club Racers advised me to do my first race at a low-speed track like GingerMan in order to get used to the driving in competition at a slower pace. However, I could start racing much sooner if I went to Road Atlanta in April. Thanks to Keith Clark for chiding me into doing my first race at Road Atlanta. Thanks also to Susan Shire who explained the step by step procedures of applying and obtaining a PCA Club Racing license. John Ruther, our Chief Driving Instructor, had confidence in me and said I would have no trouble adapting to and being competitive in club racing with my tens years of track experience at nine different tracks. Thank you, John, for your show of confidence in me and your unhesitating recommendation.

With my car prepared and my paperwork in hand I traveled to Atlanta to face the challenge of Club Racing. The help I got from the Chicago Region members didn't end when I left Chicago. Chris Ingot, our Region's Vice President, agreed to be my mentor for the race in Atlanta. Chris was also racing in Atlanta. I took to racing like a duck to water. I was comfortable from the first practice and began passing people right away. When asked how I found competitive driving after I came in from my first practice run, my reply was simply "Give me more!" I loved it.

By the ending of the weekend I was regularly making passes at turn ten and was able to made passes at turns twelve and one and in the esses. Chris made sure I touched all the procedural bases and coached me in my approach to racing. Thank you Chris for all your help and advice. One of your the best pieces of advice was to bring a snack along to the Rookie Orientation meeting on Friday night.

At the meeting, the Club Racing National Stewards, Vicki Earnshaw and Bryan Henderson, gave a clear explanation of the PCA Club Racing Rules. They also provided two insightful views into Porsche Club Racing. The start of the race was emphasized and three practiced starts were run on Saturday. I was concerned because the start line at Road Atlanta is just after a high-speed downhill turn. Bryan helpfully pointed out that although 48 cars would take the green flag there, they would be going at half speed. Indeed, I felt comfortable during the practice starts. The race starts are easier than driving on the Dan Ryan expressway where there are more lanes of traffic, more cars going faster and passing more erratically. Thanks to the Stewards.

I must also thank the whole crew at Midwest Eurosport for preparing the car and for trackside support. Eurosport was supporting 12 cars at the Road Atlanta Club Race. Thanks to my fellow racers from the Chicago region for their camaraderie, help and advice. Four of us were in the same class, F, and five of us were in the same race group, 3.

For the race I started 4th and finished 34th. I didn't make a good start but during the race I was able to pass some drivers who qualified ahead of me. With one of them I traded position three times and ended up

ahead. I was also able to get ahead of a driver who had a particular gift for making his car wider in the turns.

Speaking of competitors I thank fellow competitor Mike Courtney from the Nord Stern Region for the good advice he gave me after a practice run on how to get through turn seven. My thanks also goes to the Club Race Sponsors many of whom give more than financial support to PCA Racing by providing products, services and advice, which are a phone call away, a click away and in some cases at trackside. Many of them share the racers' enthusiasm for the sport.

My second race was at Mid-Ohio where I started 30th. The three drivers immediately ahead of me on the grid were within one second of my qualifying time. I felt I had a good chance to pass them during the race. I got by the first two drivers and began dueling with the third driver, Chip Henderson. Chip and I passed each other five times. I ended up ahead of Chip at the end of the race in 23rd place. It was a wonderful experience when Chip pulled up beside me on the cool-down lap to give me a thumbs-up, which I enthusiastically returned. At the end of the day I received the Novice Driver Award, which is sponsored by Trailex Trailers.

Thanks to the Peachstate Region and the Mid-Ohio Region for well ran and fun events. The Regions' volunteers did a fine on the grid getting us into our proper places. And as always, I give a special thanks to the corner workers who watch after our safety.

*As of 5-15-04 there are
143 Licensed Chicago
Region PCA Club Racers*

Congratulations Chicago Region PCA Club Racers ...

Place In Class			Class	Model	Race
1	GARY R	BOSS	GT4R	80 911	Laguna Seca Sprint
1	MIKE	ORIGER	C	96 993 RS	Las Vegas Sprint
6	MARTIN	BOUR	D	S 95 993 C4	Mid Ohio Sprint
9	BRENT	JOHNSON	D	S 97 993 CS	Mid Ohio Sprint
7	SCOTT	JOHNSON	D	S 84 930	Mid Ohio Sprint
2	ROBERT	KING	D	S 95 911	Mid Ohio Sprint
7	JEFF	PHILLIPS	E	S 89 944 T	Mid Ohio Sprint
3	KEITH	CLARK	F	S 88 944 TURBO	Mid Ohio Sprint
11	DOUGLAS	CROSSMAN	F	P 79 911 SC	Mid Ohio Sprint
10	CHRIS	INGLOT	F	S 91 944 S2	Mid Ohio Sprint
13	JOHN	MUELLER	F	S 93 968	Mid Ohio Sprint
3	GLENN	SAPA	GT3R	72 911	Mid Ohio Sprint
2	RICHARD	FISCHER	GT3S	82 911	Mid Ohio Sprint
2	GARY	BOSS	GT4R	80 911	Mid Ohio Sprint
1	JOHN	BONNETT	GT4S	72 911	Mid Ohio Sprint
5	MIKE	CORRAO	GT4S	75 914	Mid Ohio Sprint
3	GARY	KNOBLAUCH	GT4S	76 911	Mid Ohio Sprint
2	GEORGE	MUELLER	GT4S	74 911	Mid Ohio Sprint
3	KURT	HIPKE	GT5S	70 911S	Mid Ohio Sprint
1	BOHDAN	KROCZEK	GTP2	76 911	Mid Ohio Sprint
1	MIKE	ORIGER	B	S 93 RSA	Road Atlanta Sprint
7	BOB	HENIFF	C	1993 911RSA	Road Atlanta Sprint
6	BOB	KLASKIN	E	1989 944T	Road Atlanta Sprint
5	KEITH	CLARK	F	1988 951	Road Atlanta Sprint
26	MIKE	FAEMS	F	1989 944 S2	Road Atlanta Sprint
10	CHRISTOPHER	INGLOT	F	1991 944 S2	Road Atlanta Sprint
18	JOHN R	MUELLER	F	1993 968	Road Atlanta Sprint
4	CLAUDE	REED	G	1976 911	Road Atlanta Sprint
3	BART	CROSBY	GT3S	1987 911	Road Atlanta Sprint
4	GLEN	SAPA	GT3S	1972 911	Road Atlanta Sprint
2	GARY R	BOSS	GT4R	1980 911	Road Atlanta Sprint
1	JOHN	BONNETT	GT4S	1972 911	Road Atlanta Sprint
3	GARY L	KNOBLAUCH	GT4S	1976 911 RSR	Road Atlanta Sprint
16	ALLEN	JORGENSEN	GTC3	2004 GT3 CUP	Road Atlanta Sprint





Porsche Cayenne

The Midwest's Largest Volume Porsche Dealer
Including The Largest Selection of New & Pre-Owned Vehicles.
The Exchange Porsche, where complete satisfaction has been
our commitment to our customers for 27 years!

RAISE YOUR EXPECTATIONS
THE EXCHANGE
A Division of Somersky Enterprises Inc.



PORSCHE

2300 Skokie Valley Rd. • Highland Park • (847) 266-7000 • www.4porsche.com
Monday-Thursday 9a-8p Friday 9a-6p Saturday 9a-5p

Charity Scene

by James Drury, 2004 Charity Coordinator

Charity Report for May 2004

A few weeks ago I had the great privilege of presenting a check to The Exchange Club of Naperville for \$3,500 on behalf of the PCA Chicago Region.

When I heard about The Exchange Club I asked "who/what is The Exchange Club?" What I found amazed me and I want to share some of the facts with you. The Exchange Club is a national service organization for men and women who want to serve their community, develop leadership skills, and enjoy new friendships. The Exchange Club of Naperville was founded in 1987 and established Project H.E.L.P. as an Exchange Club Center for the Prevention of Child Abuse. Focused on stopping child abuse before it happens, Project H.E.L.P. supports parent education through the Parent Mentor Program. This program, administered by NCO Youth and Family Services and supported by the Exchange Club of Naperville, provides parent support and education through parent mentoring and offers opportunities for parenting classes as well as individual and family counseling.

Over the years the Club now gives out scholarships to graduating seniors, and helps support 50 other children oriented charities in the area. The Exchange Club has given over \$3,000,000 in direct cash support of their goals as defined by their mission statement. There are no paid staffers in the club and everyone volunteers their time.

Their big fundraisers are the Ribfest in Naperville and the Naperville Grand Prix. McDonald's Corporation is supporting the Ribfest this year. The Club has invited the Porsche Club to have another concours at the Grand Prix again this year, at no charge to the Chicago Region.



(left to right) Mark Rice, President of the Naperville Exchange Club, James Drury, and Greg Shipley, the Chairman of the Naperville Grand Prix

photo submitted by James Drury)

I want everyone to know that the Viper Club of Chicago is going to be racing at the Grand Prix this year. They have challenged us on the track. Now we all know that most Porsche have the engine in the rear, just like a go-cart and Vipers do not.

Therefore we should win. I am asking you to come on out for the concours, race the go-cart, and have a good time at the Naperville Grand Prix. Keep the last Sunday in September open on your calendar.

914 Limited



Maintenance, repair, restoration,
track preparation, new and used parts
exclusively for your 914
Brad Mayeur, PCA since 1974
Peoria, IL. 309-694-1797
veldiadv@midwest.net fax:309-698-2203
Pickup and delivery available

The
NEWEST
PORSCHE[®]

DEALER

in the
Chicago Area
is the **Oldest**
Name in
Luxury

**Loeber
Motors**



PORSCHE

Porsche Club of
America Members
Receive

15% OFF

Scheduled Maintenance or Repairs



Serving the Northshore & Chicago for Over 68 Years

Loeber  **Motors**

Loeber Motors
Service Department
847-675-1000

7101 N. Lincoln Avenue, Lincolnwood, IL
www.loebermotors.com
847-675-1000

Now Open
Monday thru Friday 7:30am-6pm
Call for an appointment

DO WE OR DON'T WE PAUSE CEMETERY RALLYE SUNDAY, JUNE 6, 2004



Registration Opens	10:30 a.m.	Meet at SUNRISE RESTAURANT
Driver's Meeting	11:00 a.m.	9 South 593 Rt. 47
First Car Off	11:31 a.m.	Sugar Grove, IL, 60544
Rallye Car Fee	\$20.00	630-466-5837

LOCATION: SUNRISE RESTAURANT is located at the northeast corner of junction Rte. 47 and Jericho Road, south of the downtown village of Sugar Grove. There is a Citco Station right next door for last minute fill up.

This rallye will be over the roads of southwest Kane County, Kendall and LaSalle Counties, which are all new to Chicago Region rallyists. The end point will be at Chicago West Restaurant in Sugar Grove at the junction of Rte. 47 and Main Street. Rallyists will enjoy the open roads of these counties where it seems the housing construction has not found them yet.

To get to the start point, take I88 west from Aurora and take the exit for Rtes. 56, 47, 30 Sugar Grove and follow the exit road to exit for Rte. 47 South. Sunrise Restaurant is south on Rte. 47 approximately 2 miles on the left just before Jericho Road.

Questions can be directed to the Rallyemaster, Ken Pesavento, 630-469-1546 or Kenneth_a_Pesavento@ml.com or Tom and Phyllis Harwood, 847-742-6804 or trh911sc@aol.com

Mail Registration to Ken and Nikki Pesavento, 2 S 430 Canterbury Court, Glen Ellyn, IL, 60137.

DRIVER: _____ Phone # _____

Member____ Applicant____ Guest of _____

NAVIGATOR: _____ Phone # _____

Member____ Applicant____ Guest of _____

Car Model _____ Color _____ SOP _____ Touring _____ Novice _____

Rallye Car Fee: \$20.00 Please make checks payable to **PCA/Chicago Region.**

Rallye Scene

To All Rallye Enthusiasts and Others Regarding the June 6th Rallye

Our luck has not been so good with this rallye and we now have found out that the end point has to be changed because the restaurant is closed until June 11th. Therefore, because some of you may be coming with two cars and wanting to leave one at the end point, we want to let you know the new place.

We will be ending the rallye at the

LINCOLN INN
1345 S. Batavia Ave
Batavia, Illinois

630-879-7147.

This is on Rt. 31, 2.80 miles north of I88 at North Aurora.

Non-rallyists are welcome to join us for the post-rallye party. Please give Ken, Phyllis, or Tom a "heads up".

We look forward to seeing you at the rallye on June 6th

For further information about Rallyes contact:

Tom or Phyllis Harwood,
847-742-6804
trh911sc@aol.com

Ken Pesavento,
630.469.1546
kenneth_a_pessavento@ml.com

2004 Rallye Schedule
Mark your calendars!

Jun 6 Rallye II*

Aug 15 Rallye III*

Sep 12 Rallye IV

Oct 16 - 17 - Rallye V

*Event Announcements in this issue of the Chicago Scene
Need a Rallye Partner? Call Tom, Phyllis, or Ken and they'll see what they can do for you.



Fischer Motors, Inc.

SPECIALISTS IN COMPETITION PERFORMANCE SERVICE

- High Performance Engine Work
- Hunter Wheel Alignment
- Race Suspension Tuning & Weight Balancing
- Transmission & Brake Conversions

Besides all sport related upgrades, we are a repair facility for German cars.

PORSCHE MERCEDES BENZ BMW VOLKSWAGEN AUDI

908 S. Northwest Highway (Rte. 14)
Between Lake Cook Roads & Dundee Road
Barrington, Illinois 60010
(847) 304-8822 - 8823

Weekdays 8 AM - 5 PM

Saturday 8 AM - 1 PM

Time For The Real Thing

by Nadine Haupt

Fresh out of school with a practice rallye under our belt, my navigator, Jim, and I set our sights on finding the Santa Fe Speedway in the first Rallye of the 2004 season. The Photo Rallye designed by Rallyemasters Dan Gallagher and Ed Barnicle was a fantastic event! Coupled with near perfect weather, every one of the 28 cars that started finished.

We started the morning off at Buck's Pit Stop in Hodgkins. Registration went smoothly as we made dinner choices and received our car number - #4. Donuts and coffee were next as we perused the Special Instructions for the rallye. At 10:30 am, Dan kicked off the event with the humorous and informational driver's meeting around the bar. The Special Instructions all had to do with the observation of various signs - horse riders crossing, a "teeter-totter", and the Santa Fe Speedway, to mention a few - and each had a specific instruction such as a change in CAST or a pause. We'd have to keep our eyes out for those!

After some highlighting and note taking, we were off at precisely 11:04 am. The odometer check went without a hitch bringing us to the parking lot of The Chalet to begin our first rallye. Fortunately, there were no ONTO instructions to follow for this rallye. The photos certainly helped to double-check ourselves throughout the day when things got tricky.

The first leg was fairly straightforward until we came upon an intersection with a checkpoint sign across the street. The Route Instruction was to turn right on German Church Road, so that's exactly what we did. Lucky for us, we made the right call. The checkpoint sign was a trick to throw you off course and make you enter the checkpoint in the wrong direction. Whew! We got through, but the Rallyemasters did catch one team.

The second leg also left from The Chalet and took us along some great stretches of road along Maple Lake and eventually brought us to the Little Red Schoolhouse. It was fun to come across other rallyers along the way - some going the right way, some going the wrong way. It didn't matter - we waved and soldiered on. Upon arrival at the Schoolhouse, we had a Special

Instruction to kiss Peggy, but she was no where to be found. Guess that Special Instruction wasn't meant to be executed!

The next leg had another trick. The instruction at one point told us to decrease our CAST by 100% for 2 minutes, then increase CAST by 100% for two minutes, then change CAST to 34. We must have read



Ken Pesavento reviews all of the Instructions - General, Supplemental, and Route - before the Driver's Meeting at Bucks.

photo by Steve Rashbaum



Checkpoint 2 - a lovely way to spend a Sunday afternoon!

photo by Russ Pesko

The Real Thing ...

that over 10 times to make sure we understood it correctly. When we approached the Bridgestone building, we pulled to the side and paused for 4 minutes. It was a little hard to sit there and watch our fellow competitors drive right by us and wave, but we were fairly certain that decreasing CAST by 100% really meant stopping. Maybe they were stopped on the other side of

the building, we thought. Soon we were back on our way and surprised to see that no one else was stopped on the other side of the building. I have to say, that made me a little nervous. Eventually we made it to the midpoint at Stonecutters in Lemont and confirmed that our 4 minute pause was right on the money. Yippee!

After a quick snack and soda, we were off again. This leg was a little

more complicated with numbered AND lettered route instructions. I think this is also the section where the infamous “teeter-totter” sign showed up from the Special Instructions. We were lucky to see that one around a small bend in the road and pull off for a short pause. As we continued through the instructions, we had to remember to execute “each instruction on its own”. That threw us into having to decide which of the lettered instructions was the correct one to take. We caught on to this trick, but we figured out that the yellow Boxster didn't. As we were traveling down the road, our friends in the yellow Boxster raced down the road in the opposite direction and did a quick turn around. Just a little further down and around the bend was the next checkpoint. If you missed the correct route instruction, you came to the checkpoint in the wrong direction. At least we were still on course.

The final leg is where Dan and Ed got us good. Again we enjoyed some beautiful tree-lined roads through the area. We still had not found the Santa Fe Speedway sign, so that was a bit concerning. Then came the “Little Cemetery”. The route instruction was to pause for one minute at the “Little Cemetery”. So, that's exactly what we did – incorrectly. There was a little cemetery off to the left side of the road. I even recall seeing a small green sign pointing to the left that said something about a cemetery. So, we stopped. WRONG. The funny part was that we were discussing the wrong reason why we should or shouldn't stop. We were convinced that it had something to do with the instruction being a lettered one rather than a numbered one. But, of course, the General Instructions state that all landmarks must be designated by a sign. There was no sign saying “Little Cemetery”. Bummer. Needless to say, we were late to the final stop.



Steve and Lee Ropach 'on the road and on course'!

photo by Russ Pesko



Bruce Janecek's rally car.

photo by Steve Rashbaum

We made it back to Buck's and completed our very first official rallye. Our goal was first to finish and then to score as best as we could. Considering it was our rookie run, we felt good about our performance. The first goal was accomplished. Slowly the remaining competitors came back to Buck's as we completed our scoring sheet and had a few beers. Everyone was a buzz about the day! And yes, everyone made it back - eventually.

As dinner started to arrive - which was fabulous! - Dan walked us through the instructions and pointed out the errors in our ways. Which then brought us to - where the heck was the Santa Fe Speedway sign? Lucky for all of us, we hadn't missed it. The sign doesn't exist anymore! Dan began his colorful reading of the results starting with 28th place. We sat anxiously awaiting our final results. Soon, the trophies were beginning to be awarded at 15th place. Cool. You mean we get trophies, too?

Now Dan was up to 10th place. We looked at each other in disbelief. I seriously thought that Dan must have misplaced our scoring sheet. Then, at the beginning of championship point awards, we were announced in 6th place. WOW! What a way to start the season!

Thanks to the rallye school and practice, we were right there at the end of the competition. Now ... to remember the General Instructions about those landmarks for the next time. Yes, we are hooked. It was a terrific day! Porsches, good weather, great people, a few beverages, and funny stories - there's no better way to spend a Sunday afternoon. We can't wait for the next one on June 6.

The ladies of "Lucky 13" - Driver Kirsten Knott and Navigator Maureen Hutton

photo by Russ Pesko

Spring has Sprung Rallye
April 18, 2004

Place	Car #	Driver	Navigator	Car	Color	Score
1	2	Tom Verachert	Don Felch	911	Gold	603
2	14	Tom Harwood	Phylis Harwood	911	Silver	616
3	12	Ron Micek	Martha Kuffel	930	Black	630
4	3	Lee Lichtenstein	Chuck Bittman	968	Blue	739
5	1	Steve Rashbaum	Susan Shire	Boxster	Black	830
6	4	Nadine Haupt	Jim Haupt	911	Black	1062
7	25	Art Kardatzke	Janet Kardatzke	Boxster	Silver	1066
8	24	Jim Jacisin	Cindy Jacisin	Boxster	Blue	1105
9	10	Mark Gadbois	Vicka Gadbois	Boxster	Blue	1126
10	6	Bruce Janecek	Mel Wostoupal	996	Purple	1136
11	11	Don Conly	Don Mancini	911	White	1196
12	15	Steve Olson	Sharon Gregor	911	Red	1280
13	9	Joe Ornelas	Del Ornelas	Boxster	Gray	1301
14	21	Ken Pesavento	Nikki Pesavento	911	Black	1302
15	26	Anita Haas	Jessica Hornick	911	Red	1430
16	17	AJ Tiller	Van Larson	944S2	Blue	1522
17	28	Dan Bacin	Linda Bacin	Mini	Gray	1529
18	19	Ray Musich	Nancy Musich	Caddy	Black	1578
19	23	Fred Jacobson	Marilee Jacobson			1712
20	22	Mark Markese	Sue Markese	944	Red	1719
21	13	Kirstin Knott	Maureen Hutton	Boxster	Silver	1731
22	18	Steve Roach	Lee Roach	996	Blue	1758
23	27	Shirley Bayliff	Samantha Bayliff	Boxster	Red	1850
24	5	Michael Musich	Laura Fleddeman	Boxster	Yellow	1889
25	16	Geo. Schaefer III	Rob Novak	Ford	Black	1924
26	7	Pondo	Debbie	Corvette	Red	2100
27	8	Peter Faehnrich	Peter Brychel	Jeep	Blue	2337
28	20	Andy Winterbottom	Susan Winterbottom			2500
	Rallyemaster	Dan Gallagher	Peggy Gallagher			
		Ed Barnicle				
	Pre-Run	Jack Stephensen	Karen Brown			
	Corner					
	Workers	Bob Cook	Shirley Cook			
		Pat Yanahan	Bonnie Yanahan			



Membership News

by Van Miller, 2004 Membership Coordinator and Debby and Ed Leed, Membership Database

May 2004 New Members

Bob Bernardi Geneva, IL 2003 911 Targa	Edward Hattersley Linda Hattersley Oak Park, IL 1986 911 Coupe	Scott Murray Nora Murray Lake Forest, IL 2002 911 Cab	Thomas Smid Marny McCaughan Riverside, IL 1982 911SC Targa
Mannie Birk Binda Birk Naperville, IL 2000 Boxster S	Vik Havalad Suresh Havalad Chicago, IL 2003 Carrera 2 Coupe	Faris Nijim Chicago, IL 2003 Carrera Coupe	Wayne Sottile Jacquie Sottile Bartlett, IL 2002 Boxster
Juan Jose' Bonilla Srah O'Neill Bonilla Winfield, IL 1997 993 Cab	David Horowitz Marci Horowitz Chicago, IL 2002 911 Coupe	Nalin M. Patel Champaign, IL 2003 911 Cab	Todd Stockton Flossmoor, IL 2000 996 Cab
Litt Clark Winnetka, IL 1997 C2S	David Kassner Barbara Kassner Glenview, IL 1999 Carrera 4	Max Plzak Wilmette, IL 1988 911 Turbo Cab	Robert Sutton Tea Sutton Chicago, IL 1998 Boxster
Bill Daugherty Lisa Daugherty Berkeley, IL 1988 911 Cab	Mark Kilgore Patricia Kilgore Arlington Heights, IL 1991 911 C2	Brad Peterson Amy Peterson Elmhurst, IL 2003 911 Cab	Gregg Tipple Janice Tipple Deforest, WI 2001 911 Turbo
James Faircloth Heather Faircloth Chicago, IL 2003 Boxster S	Richard Kohn Joan Kohn Chicago, IL 2003 911 C4S Coupe	Alfredo Rangel Missy Rangel Sterling, IL 1973 911 Targa	Jason Vasilakos Kara Scheirer Round Lake, IL 1986 944 Turbo
Stacy Ferguson Batavia, IL 1990 911 C4 Cab	Dan Johnson Katsy Johnson Wilmette, IL 1991 911 Coupe	Rob Rhoades Burr Ridge, IL 2003 Boxster	Jeff Wagner Suzanne Wagner Rockford, IL 2003 911 Turbo
Richard Fisher Gina Fisher Northfield, IL 2004 GT3	Larry Lubell Ilene Lubell Chicago, IL 1991 Carrera Cab	Slawek Ruszel Chicago, IL 1996 993 Turbo	Jeremy Weiss Jennifer Weiss Lake Zurich, IL 1986 944 Turbo
Todd Fisher Downers Grove, IL 1967 911 Targa	Larry Mascia Pat Mascia Gurnee, IL 1999 Boxster	Jack Sheridan Carol Sheridan Winnetka, IL 1998 Boxster	Tom Williford Carol Monaghan Algonquin, IL 2000 Boxster S
Gary Graves Naperville, IL 2001 942 Cab	Sharon Mehalek Daniel Mehalek Orland Park, IL 1989 C4 Coupe	Parvez Shirazi Cameron Shirazi Oak Park, IL 2004 911 Cab	Patrick Womack Burr Ridge, IL 2002 C4S
Ben Greazel Ronee Greazel Chicago, IL 2002 Boxster S	Sherrri Morissette Chicago, IL 2003 Boxster	Susan Sills Daniel Sills St Charles, IL 2004 Cayenne	Zee Zajda Samantha Zajda Deerfield, IL 1987 928 S4
Richard Greenberg Chicago, IL 2004 911 Turbo		Allen Skillicorn Hoffman Estates, IL 1997 993 Coupe	

Welcome!

June Anniversaries

Robert D. Gummow	Virginia Gummow	1959	Stacey Zann Scott	Matthew E. Scott	1994
Thomas B. Funk	Kristin Funk	1965	Jeff Neistein	Heather Neistein	1994
Ronald R. Tanton	Russell Tanton	1968	Ronald D. Bean		1994
Robert M. Casey		1975	John R. Mueller	Patricia Foltz	1994
Owen C. Johnson Jr.	Gaile Johnson	1975	Robert VonHalle	Robin W. VonHalle	1994
Lee R. Kass	Susan J. Kass	1975	Scott E. Lynn	Sharon Lynn	1995
Richard L. Gonzales MD	Patricia Gonzales	1977	Richard O'Brien	Betty O'Brien	1995
Peter Brink	Connie Brink	1980	James M. Beck	Pam Beck	1995
Walter Danes	Marie Danes	1980	Armando Almazan	Maria C. Almazan	1995
James P. Dorfman	Michael Dorfman	1980	Robert M. Johnston	Lisa Johnston	1996
Douglas Phinney	Erin Phinney	1982	Rizaldy P. Billedo	Maribel O. Billedo	1996
Robert Nelson	Barbara H. Nelson	1983	Robert W. Morrison		1996
James A. Becker	Gail Becker	1983	Lee S. Brownstein		1996
Dennis J. Raucci	Jackie Raucci	1983	Bryan S. Larson	Robin J. Larson	1996
James B. Cady	Rhonda Cady	1984	Jack Gaggini	Maria Gaggini	1997
Keith H. Orum	Cherie Orum	1984	Mark McBain		1997
Richard L. Wellek	Jeffrey A. Wellek	1986	Scott Adleman	Maria Adleman	1997
Sol Snyderman	Beth Snyderman	1986	Arnold Klein	Marci Klein	1997
Robert T. Soske	Edward Soske	1986	Lawrence S. Ross MD	Marcia S. Ross	1997
Steve Rashbaum	Susan Shire	1987	Jason M. Brown	Mary Beth Brown	1997
Susan Shire		1987	Andreas J. Fischer	Erica Fischer	1998
Gregory J. Turek	Marla S. Turek	1987	Dr. James Beard	Florentina Ramniceanu	1998
Scott D. Sheffer	Graham Sheffer	1988	Shahriar Dadkhah MD	Mohammed Dadkhah	1998
Bjorn Forsell	Birgitta Forsell	1988	James R. Matta	Timothy Matta	1998
Norbert Becker MD	Suzanne Becker	1990	Kenneth J. Collen		1998
Stephen T. Elrick	Sandra K. Elrick	1990	Walter H. Page	Caryn Krewer	1998
Bruce A. Clay	Louise Clay	1991	Thomas J. Ryan	Isabelle Ryan	1999
Paul R. McClure	Robert McClure	1991	Jerry W. McNeil	Joyce McNeil	1999
Brian Murphy		1991	Loren S. Schechter MD	Howard Schechter	1999
Douglas Crossman II	Dr. Amy Hall	1992	Donald R. Conley Jr.	Suzanne Conley	1999
Jeffry K. Boston	Anne F. Boston	1992	Cindy Jacisin		1999
Stephen R. Olson	Sharon Gregor	1992	James M. Torres	Lisa Hoffeller	1999
Steven A. Wagner	Celeste Mattern Wagner	1992	Barry Dittus	Terry Dittus	1999
Daniel A. Burkhardt	Ellen Burkhardt	1992	John Crichton	Erik Crichton	1999
Bohdan J. Kroczek	Krystyna S. Kroczek	1993	Charles L. Montagna	Tammy B. Montagna	1999
Dr. Bruce Farkas	Debby Farkas	1993	Stephen Wiseman	Heidi Wiseman	1999
Denise Evans	Terry Crase	1993	Richard Indyke	Cynthia Indyke	1999
Peter B. Hackenson	Brandon Hackenson	1994	Stephen L. Schlader	Lynise Schlader	1999

Anniversaries ...

Thomas J. Simmons	Kelly Simmons	2000	Patrick P. Yanahan Jr.	Michelle Yanahan	2002
Darryl Hughes	Devin Hughes	2000	Chuck LaMantia	Melissa LaMantia	2002
Donald T. Elliott	Sonja Elliott	2000	Craig J. Chambers	Debbie Chambers	2002
John M. Heffron	Judy Heffron	2000	Keith C. Wagner	Seth Wagner	2002
William S. Schilling	Vicki Schilling	2000	Dan Ward	Connie Ward	2002
Marian Young	Brady Young	2000	William A. Terbell		2002
Robert P. Weber	William P. Weber	2000	Mark S. Soucy	Tracey Soucy	2003
Scott A. Massey	Lori Sutter	2000	Robert J. Berman		2003
John G. Kall MD		2000	Howard Horn	Judith Horn	2003
Dennis Fiedler	Rick Gunderson	2000	Jeffrey R. Parnell	Michelle Parnell	2003
Charles F. Hunnicutt	Judy Hunnicutt	2000	Rudolf J. Schick	Marion Weedermann	2003
Carl Gergits	Cheryl McCabe	2000	Glenn P. Watamanik	Lisa Larsen	2003
Tom Foley	Jan Foley	2000	Dale L. Sprosty		2003
David J. Youngblut	Mary Youngblut	2000	Dean Papanik	Peter Papanik	2003
James S. Hauert	Kim Hauert	2000	Greg P. Martin		2003
Scott E. Denmark		2001	George Rademacher		2003
Fred E. Schulz	Carol M. Schulz	2001	JR Scassellati		2003
Randal G. Loomis	Nancy Loomis	2001	Joseph Salamunovich		2003
Dan D. Cubric		2001	Torrance M. Fiorovante	Kris Fiorovante	2003
Stephen Kroah	Don Chaney	2001	Joseph Limas	Christine Limas	2003
Michael Semersky	Roxanne Semersky	2001	Karen R. Morse		2003
Catherine M. Campbell		2001	William D. Parise	Kathryn L. Parise	2003
Donald M. Petkus		2001	Carlos M. Segura	Sun Segura	2003
Kenneth J. Krajniak	Christopher T. Dundon	2001	Fred R. Jacobson	Eric Jacobson	2003
Michael Flaska		2001	Frank Spinarski		2003
Patricia M. Davis	Michael W. Davis	2001			
Susan L. Borchering	James W. Borchering	2001			
Ron Lapporte	Ginny Lapporte	2001			
Carol Koenig	Joe Koenig	2001			
William E. Malone	Robin Malone	2002			
Steven E. Dowdy	Sarah Dowdy	2002			
Robert Francisco	Nancy Francisco	2002			
Douglas A. Cunningham	Tina Cunningham	2002			
Michael J. Head	Barbara A. Head	2002			
Carlton D. Walstad		2002			
John J. Neis	Michael J. Birch	2002			
Keith E. Onchuck		2002			
Gregory C. Lewis	Sharon Lewis	2002			

MANNY'S
PERFORMANCE, INC

16651 VINCENNES AVE. • SOUTH HOLLAND, IL 60473

Servicing, modifying, racing and restoring
Porsche cars since 1964

708-333-6606

By appointment only
WE DO IT RIGHT - THE FIRST TIME!



PCA CHICAGO REGION 2004 DRIVERS' EDUCATION EVENTS

Drivers' Education is a medium to high speed (top speeds can be from 90-130 mph) event on a closed course (race track). Multiple cars are on the track simultaneously with tightly controlled passing rules. No racing is tolerated. This is not a timed event, and there is no competition. Both classroom and in-car instruction, utilizing approved PCA Instructors, are an integral part of these events. Skills practiced include choosing the optimal path around a road course, controlling a vehicle at its cornering limits, slowing a vehicle, and utilizing controlled situations to improve understanding of vehicle dynamics. Please check the latest issue of "Chicago Scene" for event locations and starting times.

CHICAGO REGION DRIVERS' EDUCATION VENUES

Blackhawk Farms Raceway: 1.8 mile road course with 7 turns, located in South Beloit, IL

Gingerman Raceway: 1.88 mile road course with 11 turns, located in South Haven, MI

Road America: 4 mile road course with 14 turns, located in Elkhart Lake, WI

DRIVERS' EDUCATION 2004 EVENT SCHEDULE

- | | |
|---|--|
| ✓ Friday, June 11 | Blackhawk Drivers' ED |
| ✓ Friday, July 23 | Blackhawk Drivers' ED |
| ✓ Saturday, August 7 & Sunday, August 8 | Gingerman Raceway Drivers' ED |
| ✓ Wednesday, August 18 | Blackhawk Drivers' ED |
| ✓ Friday, Sept. 3 thru Monday, Sept. 6 | Road America Drivers' ED Labor Day Weekend |
| ✓ Wednesday, September 15 | Blackhawk Drivers' ED |
| ✓ Saturday, October 2 & Sunday, October 3 | Blackhawk Octoberfest Drivers' ED |

DRIVERS' EDUCATION EQUIPMENT REQUIREMENTS

REQUIRED:

- ✓ 1995, or later, SNELL SA approved helmet. (No M rated Motorcycle Helmets)
- ✓ Full length pants, long-sleeved shirt, and socks of non-synthetic materials
- ✓ Full shoes. No bare feet, sandals, open toed or thick-soled shoes
- ✓ Original factory installed belts for Novice, C & B2 run groups
- ✓ 6 point harness system with stock seat (H strap without harness bar) - or - race seat and 5 or 6 point harness system for all other classes and Class B at Road America
- ✓ Harness and seats must be similarly equipped for driver and instructor side
- ✓ Refer to 2004 Tech Inspection Sheet for additional information and requirements

RECOMMENDED:

- ✓ Competition brake pads and fluid
- ✓ Driving suits, driving shoes, neck collar, and gloves made of fire resistant materials
- ✓ Fire extinguisher

RECOMMENDED FOR MORE ADVANCED DRIVERS/FASTER CARS:

- ✓ Roll bar or roll cage
- ✓ DOT approved race tires (e.g. Hoosier or G Force)



Blackhawk Drivers' Education

FRIDAY *Yes, FRIDAY*, June 11th

Here it is, the first FRIDAY event at Blackhawk. As you know, Blackhawk is a great road course close to home in Rockton, Illinois. **This is our FIRST FRIDAY event - for Experienced & Novice Blackhawk drivers.** Since most Blackhawk events are sell-outs, pre-register as early as possible to assure a spot. Waiting lists will be used to fill any open spots. Cancellations & refunds will be honored until 9 p.m. on the Monday prior to the event.

Mandatory clothing for all drivers at this event includes: a Snell SA 1995 or 2000 Helmet, long sleeve cotton shirt, long pants, socks, all made of non-synthetic materials, and closed toe shoes. Recommended but not mandatory are: driver's suit, driving gloves, driver shoes and a protective neck brace all made of Nomex or similar fire-resistant material, as well as a mounted fire extinguisher. Please check the date on your helmet now, as it will be inspected during the Tech Inspection at the track. **If you and your car do not pass Tech Inspection, you will not be able to drive.** You will be required to show a valid drivers license (no tickets accepted) along with a valid PCA Membership at registration.

You can save time at the track by bringing your car to a recognized Porsche Dealer or Porsche Specialty Shop for mechanical inspection and having them complete, sign and stamp the Chicago Region Tech Inspection Sheet. Review the NEW Updated Year 2004 Tech and Safety Requirements – there are changes from the prior year! Pay particular attention to specifics concerning brake pads and fluid, since Blackhawk Farms is very hard on the brake system!

Blackhawk Concession Stand serves breakfast from 9 a.m. until 10 a.m., lunch from 10 a.m. until 1:30 p.m. The Accessories Store has gas (leaded & unleaded Race only), air, and showers that are open all day.

General Event Schedule:

- 8:00 a.m. - Registration & Tech Open
- 9:00 a.m. - Mandatory Drivers' Meeting
- 4:30 p.m. - Last Car off Track

Directions From Chicago: Take I-90 west to the Rockton Road exit (about 15 miles north of Rockford.) Go west (left turn) on Rockton Road, approximately 5.5 miles and through town of Rockton to Prairie Avenue. Go north (right turn) on Prairie Avenue, approximately 1.5 miles to the track, which will be on your left.

* Mobil station 2 blocks south of Rockton Rd. on Blackhawk Blvd.

First Driver

Year/Car Make/ Model/ Permanent Car Number _____

Phone _____

E-mail
(circle ALL applicable) Member Non-Member Guest of: _____

Run Group:
[Instr/Red] [A/Black] [B1/White] [B2/Yellow] [C/Green]

Prior Experience: _____

Second Driver (same car)

Phone _____

E-mail
(circle ALL applicable) Member Non-Member Guest of: _____

Run Group:
[Instr/Red] [A/Black] [B1/White] [B2/Yellow] [C/Green]

Prior Experience: _____

Pre-registered Entrance Fees received by June 9th, 2004:

Member First Driver - \$160	\$ _____
Family Member-2nd Driver - \$80 *	\$ _____
Non-Member - \$170	\$ _____
Registration received after June 9, or On site registration add \$10	\$ _____
Total	\$ _____

* The \$80 fee only applies to 2nd family member who drives the same car as the first driver. A non-member = \$160

Make check payable to: PCA- Chicago Region

Mail to: Todd Conforti - Blackhawk Drivers' ED Registrar
553 West Carboy Road
Mount Prospect, IL 60056
(847) 382-9653 home (847) 952-0070 work
e-mail: tlcontrols@aol.com

For more information on Track Events, Schedules, Tech & Safety Requirements use the WEB at WWW.PCA-Chicago.org
For more Blackhawk information go to WWW.namotorsports.com/Tracks/Blackhawk.html.

The Bulletin Board

Notes, e-mails, and info from other Regions, National, various websites, and the rest of the universe ...

PCNA Porsche Supercup Dinner and Race Tickets

Porsche Cars North America and the Central Indiana Region of the Porsche Club of America are pleased to announce the Third Annual Porsche Supercup Dinner to be held on Saturday, June 19th in conjunction with festivities surrounding the U S Grand Prix Formula One race.

This year's Supercup Dinner will be hosted at the Walker Racing facility in Indianapolis and feature a variety of current and vintage Porsche's including the 1989 Porsche Indy Car that was piloted by Teo Fabi under the direction of Derrick Walker. The dinner will feature a special "keynote" speaker and several Porsche Supercup drivers talking about their experiences with Porsche and the Supercup program. Again this year, the United States Grand Prix festival committee, in conjunction with CIR PCA, will hold the Porsche Grand Car Cruise through downtown Indianapolis. The Supercup Dinner will follow the Car Cruise enabling dinner attendees to participate in both the cruise and dinner.

Seating is limited therefore early registration is encouraged. The \$55.00 registration fee per attendee includes access to the Walker Racing facilities, a selection of beer and wine, dinner and desert. Registration information: www.cirpca.org.

Porsche Cars North America has made special arrangements with the track for PCA members. The "best in the house" seats are located in section H (1st turn coming off the oval). Race tickets are \$105. Please contact 1 800-822-INDY and ask for Carole. Please specify that you are a PCA member, have your PCA membership number available, and want to sit in the Porsche Cars North America block.

Milwaukee Region To Renovate Porsche Park

The Milwaukee Region is renovating Porsche Park at Road America. Currently the park is little more than a field with a fallen fence and a small sign. Plans include replacing the fence and some of the plantings, and returning Porsche Park to a location where Porsche owners will want to gather at Road America.

For information regarding the Renovation Program, please contact Dan Matre, Porsche Park Renovation Chair at dmatre@sbcglobal.net.

The Grand Reopening and Rededication Ceremony is July 17, 2004 during the BRIC weekend.

Other Gingerman DEs

6/12-13 Michiana PCA, contact Don Dosmann, MichianaPCA@aol.com

7/14-15 Rally Sport PCA, contact Christian Maloof at 734.424.0818

The Art Of The National Sports Car Exhibition

The Snite Museum of Art at the University of Notre Dame, will exhibit five sports cars from the private collection of Thomas Mittler from June 13th to August 29th. The automobiles on display will be: 1951 Cunningham C-2R, 1956 Jaguar D-type, 1959 Deutsch-Bonnet La Mans Prototype, 1959 Porsche RSK Spyder, and 1954 Ferrari 500 Mondial.

These automobiles will be exhibited in an art museum to underscore their exceptional design; that is, the fact that they can be appreciated as functional sculpture. The exhibit will vividly demonstrate how sports cars of the 1950s reflect the style and the culture of the nations that produced them.

The exhibit will be free and open to the public. For further information, please call Museum Information at 574.631.5466 or on-line at www.nd.edu/~sniteart



- All German vehicles welcome!
- Free admission to the Museum & Pioneer Airport for all occupants of German cars!
- Free souvenir dash plaque for the first 200 participants!
- Rides available in a variety of vintage airplanes (cost \$30-\$60)
- There will be a gathering of classic German airplanes!

Gates open 8:30 a.m. on Saturday September 11, 2004. German Cars are requested to arrive before 10:00 a.m. The day ends at 4:00 p.m. Food is available -or bring your own. No judging.

**For more information visit:
www.airventuremuseum.org**

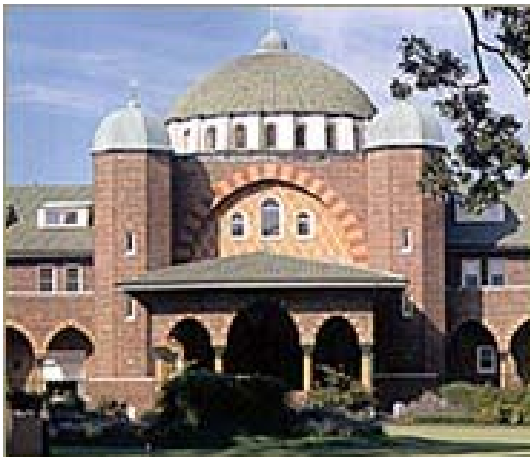

Concours One

11:00 am - 3:00 pm

Social

Lunch 11:30 am - 1:30 pm

Medinah Country Club

6 N 001 Medinah Road, Medinah, IL
(1/2 mile north of Lake St on Medinah Road)

June 13, 2004

"Let's do lunch and Porsches at 'the Club' on the 13th"

10:00 am	Concours participants may arrive & do final prep
11:00 am	Everyone else may arrive ... Family, friends, and non-participating members are encouraged to attend!
11:30 am - 1:30 pm	Lunch and CASH BAR
Noon	Judging begins
2:00 pm	Trophy presentation

Medinah Dress Code

NO Jeans, Denim or Tee Shirts

Dockers or equivalent Collared or Button Polo shirts

Concours Fee*

Pre-registered	\$25.00
On-site registration	\$30.00

Lunch

Pre-registered	\$20.00 per person
On-site cost	\$25.00 per person

- Class A: Exterior, Interior, Trunk, Engine & Undercarriage
- Class B: Exterior, Interior, Trunk, & Engine
- Class C: Exterior, Interior, & Trunk,
- Class D: Exterior & Interior
- Class E: Exhibition Style of Exterior & Interior - Visual Inspection Only
- Novice: For fun and 1st time participants only - Judged to Class C Standards

Concours Questions?

Van Larson
630.377.4886
Valyr9090@aol.com
A J Tiller
312.735.8771
aj2manycars@aol.com

R.S.V.P. with registration form and check to: Mike and April Milhouse (708.922.9623)
2514 Spruce Road
Checks payable to PCA Chicago Region Homewood, IL 60430

Concours Entrant _____ phone _____ e-mail _____

PORSCHE Model _____ Body Style _____ Year _____

Class (circle) A B C D E Novice

**Concours registration includes one (1) lunch. Extra pre-registered lunches available at \$20.00 each*

	Concours fee	\$ _____
Concours Entrant Lunch	<u>1</u>	\$ <u>N/C</u>
Additional Lunches @ \$20.00 each	_____	\$ _____
Totals Lunches ordered	_____	Enclosed \$ _____

Q-tip Corner

The 5 Ps

by Van Larson

Polish,
Preserve,
Protect (your)
Porsche's Paint

Now that all of your paint chips have magically disappeared as a result of the Yanahan method duly applied to your Porsche, it is time to move on – the next logical stage is the polishing, preserving and protection of your P car's paint. Do not be confused by equating "polishing" with waxing/protecting. Your paint should be "polished" first, then protected by wax or other "preservatives" which will not rectify a poorly prepared paint surface.

It is suggested that your paint be "stripped" of previous coatings by a good car wash using "Dawn" or other dishwashing liquid. Use a good, dedicated car wash solution thereafter for a second wash. You might consider, depending on the condition of your paint, to do a "clay-bar" regimen - just be sure to use a LIBERAL application of the appropriate wetting solution and frequently "turn" the clay to expose uncontaminated surfaces while you work. Use front to back motions and try to do only one panel at a time, keeping the surface well

lubricated. You don't have to apply much "downforce" on the clay and when the bar starts to slide smoothly over the paint surface, move on to the next section.

Again, first timers might want to try this technique on your prized Yugo before befriending the Porsche

Now, dig out last month's Scene "Q-TIP" article and review the "Blue Magic" two step road to the ultimate shine, if your paint still looks weary and in need of some perking up. Remember, you want to remove as little of the old paint surface as possible – less is more!

Should you consider a machine polisher as part of this process? Good question. Many "swear" by them and excellent results can be achieved with proper use. As usual, practice makes perfect. Speaking for myself, my favorite upper body/torso/arm exercise comes from a "hand job" - how better to explore the sensuous curves, nooks and crannies of Dr. Porsche's creations?!

Speaking of Porsche paint and polishing machines, I came across an interesting web-site article at: <http://edit.store.yahoo.com/lib/hawgwash/GermanCarProducts.html>. The article by Terry Freiberg of Classic Motoring Accessories sheds

some insight on Porsche's painting protocols and why some "waxes" seem to produce not so happy results. This article also details some new European based machines and other polishing/waxing/protection products which I have not previously been exposed to.

Now would also be a good time to check out the CONCOURS forum of our Chicago PCA website that conveniently "lists" some recommended products used by local gurus. Please let me make a "plug" for our local SCENE advertisers who can usually supply these products along with many other P-car related essentials, although some specific items may only be available by mail order or on-line from the manufacturers' website.

Remember that our own Bruce Janeczek recently contributed a SCENE ditty listing some of his favorite P-car related websites which can be consulted for product information/purchasing - now we know where to get those removable magnetic flames and louvers that many have lusted over! I'll add some of my own sites shortly.

Next month we will finish off the finish as this saga drones on – stay tuned.



Century 21
Advisors, Inc.

1816 S. Arlington Heights Rd.
Arlington Heights, Illinois 60005
Office (847) 952-0909
Fax (847) 952-0961
Cellular (312) 404-9965
E-Mail newhome4u@comcast.net
Website www.advisorsrealty.com

Each Office is Independently Owned And Operated



Peter Sygieda
REALTOR®





MPH
TECHNOLOGIES, INC

Small Business Computer Network Installation, Repairs, Security

www.mphtechnologies.com
Michael Hill michael@mphtechnologies.com
Network Integrator 708.415.0769

The Autocross School

photos by Chris Inglot

Event Recap From The Co-chair by Ed Leed

The weather was great for the first autocross oriented event of the 2004 season ... in spite of the damp forecast. From the grins on everyone's faces, a great time was the result.

Sixty two novice drivers attended this all day event which was chaired again by myself, Ed Russ and Christy Russ. Included were three young PCA Junior Participant Program drivers which is focused on 16 to 18 year old sons and daughters of PCA members: Jason Chambers, Alexandra Dabek and Karl Nielson. We also had two second generation PCAers attend their first autocross school: Ruann Tiller and Alex White.

Following my ninety-minute class, everyone hit the huge Maywood Park parking lot for the skid pad, braking practice and slalom exercises which was very well organized by Ed and Christy Russ. This year's lunch offering of boxed

lunches allowed exercises to proceed at an even pace. At about 3:00, everyone had their first opportunity to drive a complete autocross course which really had everyone pumped. We definitely have some very talented new autocrossers among our novice drivers.

A huge Thanks! goes out to a big group of Chicago Region volunteers who help with the autocross school knowing that they will not get a chance to drive. All they do is work all day for the benefit of the students who gain the knowledge of these volunteers' many years of experience.

This year, our volunteers, in addition to event chairs, were Patty Jacisin, Jim Jacisin and Debby Leed who registered everyone with amazing efficiency; Toby Duckett, Mike Hill and Pete Hackenson who inspected every car with careful scrutiny; and instructors Ed Barnicle, Nick Brenkus, Keith Clark, Mo Dadkhah, Bob Danko, Peter Faehnrich, Chris Inglot,



Event co-chair and classroom instructor Ed Leed

Bruce Janecek, Bill Kidder, Chuck LaMantia, Scott Lynn, Russ Pesko, George Schaefer, Steve Wagner (pictured below) Bob Soske, and AJ Tiller. If I have overlooked anyone, please let me know so that you receive the recognition you deserve in next month's Scene.





day was an old 745 BMW that, well, had seen better years but the guy had wheel spin down to a science. Too bad the tires will need replacement. A newer BMW 325 did a good job for a young man. A young lady driving a 924 was perfecting the brake stop run and her dad was jumping up and down when she got it right. Isn't it great? We welcome the youute! (my cousin Vinny)

Another Year, Another AX School

by Mike Rende

Control, control, control! So why did you buy a Porsche? What do you like to do with it? Do you drive it, look at it or keep it in the garage. Doesn't matter. We all love them and with a Porsche all these things are possible.

For those who wish to drive our cars we have again had our yearly Autocross school to pump up our skill set. Ed Leed taught the class and Christy Russ and her Dad Ed ran the parking lot. Many officers attended to assist. Jim Jacisin, forever smiling, was helping the brake zone and Chris Ingot took pictures, just like the old days.

I can still remember my first AX school at the Joliet Speedway parking lot. My introduction to G forces for sure. Now, after a few years driving autocross, a couple of good days with a 1st place trophy, and a bunch of hot, worn out, dragged out days losing to everyone, I can honestly say "IT'S STILL A BLAST to drive my Porsche. Of course I drive anything I can get a shot at because it's what really helps me understand the differences and the similarities in cars. Thus the skill set goes up. Isn't that why we have the car? And isn't that why we want to learn more?"

Not limited to just Porsches, our school welcomes the likes of Audi, BMW, Mercedes Benz, Mazda and more. The prize tire smoker of the

Then there were some of the prettiest Porsches that I have seen this year: newer 996 Turbos, 993 Carerras and Targas, 914-6 and a couple of classic 911 and 912 types. Every year I get to see a new group of people, help them learn their cars dynamics. WHAT A BLAST! Sometimes we have a real good time watching the young as well as the old, school kids and doctors alike learning new motor skills.

Our day on the tarmac was as usual, not sunny but at least we had no rain and no blowing sand. Ever try driving slalom with sand on the pavement? We did once and it was a real challenge. Good-bye fender.

Here are some things we learn by doing. Driving around the parked cars and lining up in two lines for the start line. Switching drivers when there are two drivers registered in the same car ... there is always a two-driver lane at AXs. How to wait. (This is the time for attitude adjustment and course review).. How to look at the slalom and figure out whether to go to the



AX School ...

left or right of the first cone ... happens at every AX. There is always a better line. How to modulate the gas during the slalom and the curves to achieve optimum push or drift. (Remember over/under steer?) How to push the pedal in parts of an inch rather than full on or full off. And the brake pedal needs kindness too. You should know which class your car is in. Pack a plastic cover for all your stuff when you empty the car. Bring a cooler, chair and umbrella too. Oh, sunscreen is required ... especially on the nose. And the guy with the little paper patch on his nose-well talk to him at AX-he will probably be one of the fastest cars there. His name is Tony. Tell him I said HI!

Well fellow drivers I'm off for now. Time to check the brakes, fluids, tires, helmet and all that. I hear there's an AX soon. Too bad P2 is a bust. Guess I need a Turbo.



CHANGE OF ADDRESS

Name(s)

Old Address

NEW ADDRESS

Home Phone

Fax

Work Phone

e-mail

Mail, fax or e-mail to: Debbie Leed, 37 Lakeview Drive, Barrington, IL 60010-1949 / Fax 847.382.3562 (8:00 am - 8:00 pm only) / Leedlast@hotmail.com



Autocross II

June 27, 2004

PCA CHICAGO REGION

9:00 - 10:00 am	Registration* and Tech
10:15 am	Tech closed
10:15 am	Driver's Meeting
10:30 am	First car off
3:30 pm	Trophy Presentation

Directions to Rockford Speedway:

- From the West: Hwy 20 (bypass) East to Meridian Rd. North 8 miles to Latham Rd. East 8.1 miles to Rockford Speedway.
- From the South: I-39 North to Hwy 20 (bypass)/I-90 West (Madison). Then follow "From the East."
- From the East: I-90 West/North to Riverside Blvd (Exit 66). West 1 mile to Perryville Rd. North 5 miles to Hwy 173. West 1/2 mile to Rockford Speedway.
- From the North: I-90 South to Rockton Rd. West 1 mile to Hwy 251 South. South 6.6 miles to Hwy 173. East 1 mile to Rockford Speedway.

Driver #1	\$35.00 Member	\$40.00 Non-Member Guest - Member MUST be present
Driver #2	\$15.00 Family Member	\$40.00 Non-Member Guest - Member MUST be present
	\$35.00 Member sharing car with other Member	

GENERAL RULES: Required - Snell 1990 helmet, full-length pants, long-sleeved shirts, socks and full shoes. Member may bring one guest. Guest may drive member's Porsche or a two door sports car. Associate Member driving a non-Porsche is considered a Guest. Maximum two drivers per car. Member MUST be present with Guest. Only first car driven will trophy. Valid driver's license at Registration. *On-site registration, checks only, please.

Mail (with check) to: Fred Howard 815.389.1966
 12534 Thistle Ridge Court
 Roscoe, IL 61073

Driver #1 _____ Member Guest**
 _____ Phone number

Car Model Chicago Region Permanent # Member Guest**
 Driver #2 _____

_____ Phone number
 Car Model Chicago Region Permanent #

** _____ Total enclosed _____

Guest of Member MUST be present Checks payable to PCA Chicago Region

Chicago Region Goodie Store

The Goodie Store has made a successful debut into the 2004 Chicago Region PCA season. Sales have been brisk at the General Membership Meeting, Chili Cook-off / Concours School and the recently held Autocross School. Sales were especially brisk at the Autocross School and would have been better if the event coordinators did not interrupt business for the drivers meeting prior to the start of the final session!

The best of plans still did not hold as we were not able to set up at Medinah Country Club (understandably) nor at Dave and Busters (not really understandable) in support of the Rallye School.

We will keep our eye on the event calendar and make sure to attend autocross and rallye events.

The initial inventory items are still available but supplies are running low. The original order totaled 99 items of which 70 have been sold. In total, the Chicago Region logo can be seen on over 100 items sold this season.

Available at this time are the following items:

Long sleeve button down denim shirts	\$30.00
Long sleeve button down white shirts	\$35.00
Fleece jacket - Half Zip - Black	\$33.00
Fleece jacket - Full Zip - Gray	\$35.00
Waterproof rain gear (Jacket and pants)	\$87.00

All sizes are still available as the best sellers of the denim shirts and black fleece have been reordered.

All of the above items (with the exception of the rain pants) have the Chicago Region Logo on the front. In addition, with the exception of the rain gear, a large or small Club Racing logo may be added on the back. The small Club Racing logo adds \$8.00 and the large Club Racing logo adds \$20.00.

The goal of the goodie store is to break even. The only exception may be the rain gear! Given the unusually high number of wet track days last season, special excise taxes may be added while the rain is falling. So, purchase early!!

Watch for new items and if you would like any of the current items but cannot make it to an event, please send an e-mail and we can take care of the order.

We will definitely be at Road America and other future events. Plan ahead and bring that extra blank check!



Chuck LaMantia

&

Keith Clark

630.510.7418 or claman1022@msn.com

630.690.3381 or ClarkFNFlying@aol.com

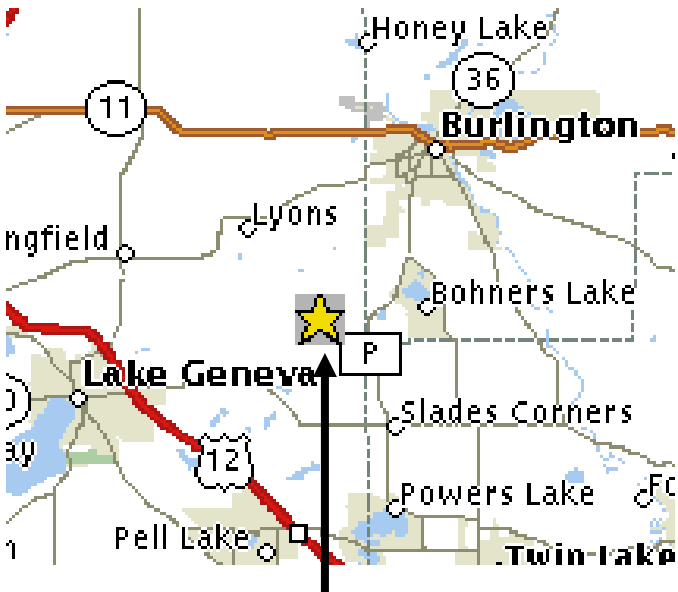

Autocross III

July 18, 2004

PCA CHICAGO REGION

MGA PROVING GROUNDS

- 9:00 - 10:00 am** Registration and Tech
- 10:15 am** Tech closed
- 10:15 am** Driver's Meeting
- 10:30 am** First car off
- 3:30 pm** Trophy Presentation

Directions to MGA Proving Grounds

From Chicago (O'Hare International Airport)
 Start out going East on I-190 E. (1.3 miles)
 Merge onto I-294 N via exit number 1C toward MILWAUKEE/I-90 W/ROCKFORD (Portions toll). (13.1 miles).
 I-294 N becomes I-94 W (Portions toll). (29.6 miles)
 Take the WI-50 exit- exit number 344- toward KENOSHA/LAKE GENEVA. (0.3 miles)
 Turn LEFT onto 75TH ST/WI-50 W. Continue to follow WI-50 W. (17.7 miles)
 Turn RIGHT onto CR-P/DYER LAKE RD. Continue to follow CR-P. (2.4 miles)
 Turn LEFT onto WARREN RD. (0.1 miles)

Driver #1	\$35.00 Member	\$40.00 Non-Member Guest - Member MUST be present
Driver #2	\$15.00 Family Member	\$40.00 Non-Member Guest - Member MUST be present
	\$35.00 Member sharing car with other Member	

GENERAL RULES: Required - Snell 1990 helmet, full-length pants, long-sleeved shirts, socks and full shoes. Member may bring one guest. Guest may drive member's Porsche or a two door sports car. Associate Member driving a non-Porsche is considered a Guest. Maximum two drivers per car. Member MUST be present with Guest. Only first car driven will trophy. Valid driver's license at Registration.

REGISTER ON-SITE please bring this completed registration form

	Member	Guest**
Driver #1 _____		
_____	Phone number	
Car Model	Chicago Region Permanent #	
	Member	Guest**
Driver #2 _____		
_____	Phone number	
Car Model	Chicago Region Permanent #	
** _____	Total enclosed _____	
Guest of	Member MUST be present	Checks payable to PCA Chicago Region

Autocross In A BMW X-3

by Michael Rende

photo submitted by Mike Rende

With A Little Help From John Rutherford IV

You might think that autocross in a sport Ute or 4-wheel drive is an ill advised activity. How about this? BMW wants you too! In fact, they set up the course, provided the vehicle, instructor and the usual snacks. Just like the X-5 introduction about 4 year ago, it was a structured and educational-non-sales pitch-event. Although not as lavish as the Jaguar test-drive at Road America last year, it was far more practical.

As with the autocross and DE events in many car clubs, the session begins with a classroom instruction that focuses on vehicle control using the three primary inputs: accelerate, decelerate and turning. Balance is critical as is anticipation. The crisis turn and panic stop are reviewed as they pertain to fear. Fear stops our thinking and causes us to freeze ... always the worst option. The better you can anticipate, control and respond, the safer you are. Safety is always the object of a better driver. (Gosh, isn't this just like everything you've heard at the Porsche club?) That's why I try to get around to all these different events. I drive anything! Especially if it's free.

Now to the track. We waited for the first group to come around and took the next black X-3. (My weakness in colors) A smallish build, the instructor introduced himself: John Rutherford. He took the wheel and showed us the line. And there really was one. I was holding on as he really nailed it. Don't they always do that? I asked about his experience and it was in the Grand Am Series.

As usual, it was a series of cones on a flat asphalt strip. Here's a good idea: they used a green cone at the apex of the turns. Didn't look logical from the ground but after driving a few laps I found out why they were there. A good visual focal point. The

turns were just a bit tricky and if you turned in too early, guess what, you ran out of track ... just like other events. Modulate, pick a point and turn smoothly ... which was the first session's lesson. Smooth, and then smoother.

Moving on, we had a break, a small classroom talk about a bit of advanced skills and then waited for the next round. So, around and around we went. Human nature being what it is I found that I was really pushing the car too hard now that I had the feel of it.

Over to the side a driver spun one of the X-3's really well. "Hey, toss it little harder" I thought. Can't seem to roll these little Ute's, on asphalt anyway.

Meanwhile, well, I worked on smoothness and trying to avoid the



John Rutherford IV (left) and Mike Rende

pedal to the metal which caused the tranny to down shift, which caused the instructor to have to push it back to second.

After we stopped I asked John if there was a connection to some guy named Johnny who won Indy and a bunch of other races and sure enough, same family (Wonder how much this would have cost at a real driving school?)

FOREST AWARDS & ENGRAVING

336 E. IRVING PARK RD. • WOOD DALE IL 60191

WWW.FORESTAWARDS.COM

SUPPLYING THE CHICAGO REGION PORSCHE CLUB
WITH TROPHIES & AWARDS FOR OVER 10 YEARS
ALONG WITH AWARD WINNING CUSTOMER SERVICE

CONTACT NICK BRENKUS (PCA MEMBER SINCE 1978)
FOR ALL YOUR CLUB & CORPORATE EVENT AWARDS

847-426-9199



Blackhawk Drivers' Education

FRIDAY *Yes, FRIDAY*, July 23rd

BLACKHAWK DRIVERS' EDUCATION

Here it is, the SECOND FRIDAY event at Blackhawk. As you know, Blackhawk is a great road course close to home in Rockton, Illinois. Since most Blackhawk events are sell-outs, pre-register as early as possible to assure a spot. Waiting lists will be used to fill any open spots. Cancellations & refunds will be honored until 9 p.m. on the Monday prior to the event.

Mandatory clothing for all drivers at this event includes: a Snell SA 1995 or 2000 Helmet, long sleeve cotton shirt, long pants, socks, all made of non-synthetic materials, and closed toe shoes. Recommended but not mandatory are: driver's suit, driving gloves, driver shoes and a protective neck brace all made of Nomex or similar fire-resistant material, as well as a mounted fire extinguisher. Please check the date on your helmet now, as it will be inspected during the Tech Inspection at the track. **If you and your car do not pass Tech Inspection, you will not be able to drive.** You will be required to show a valid drivers license (no tickets accepted) along with a valid PCA Membership at registration.

You can save time at the track by bringing your car to a recognized Porsche Dealer or Porsche Specialty Shop for mechanical inspection and having them complete, sign and stamp the Chicago Region Tech Inspection Sheet. Review the NEW Updated Year 2004 Tech and Safety Requirements – there are changes from the prior year! Pay particular attention to specifics concerning brake pads and fluid, since Blackhawk Farms is very hard on the brake system!

Blackhawk Concession Stand serves breakfast from 9 a.m. until 10 a.m., lunch from 10 a.m. until 1:30 p.m. The Accessories Store has gas (leaded & unleaded Race only), air, and showers that are open all day.

General Event Schedule:

- 8:00 a.m. - Registration & Tech Open
- 9:00 a.m. - Mandatory Drivers' Meeting
- 4:30 p.m. - Last Car off Track

Directions From Chicago: Take I-90 west to the Rockton Road exit (about 15 miles north of Rockford.) Go west (left turn) on Rockton Road, approximately 5.5 miles and through town of Rockton to Prairie Avenue. Go north (right turn) on Prairie Avenue, approximately 1.5 miles to the track, which will be on your left.

* Mobil station 2 blocks south of Rockton Rd. on Blackhawk Blvd.

First Driver

Year/Car Make/ Model/ Permanent Car Number

Phone

E-mail
(circle ALL applicable) Member Non-Member Guest of: _____

Run Group:
[Instr/Red] [A/Black] [B1/White] [B2/Yellow] [C/Green]

Prior Experience: _____

Second Driver (same car)

Phone

E-mail
(circle ALL applicable) Member Non-Member Guest of: _____

Run Group:
[Instr/Red] [A/Black] [B1/White] [B2/Yellow] [C/Green]

Prior Experience: _____

Pre-registered Entrance Fees received by July 21, 2004:

Member First Driver - \$160	\$ _____
Family Member-2nd Driver - \$80 *	\$ _____
Non-Member - \$170	\$ _____
Registration received after July 21, or On site registration add \$10	\$ _____
Total	\$ _____

* The \$80 fee only applies to 2nd family member who drives the same car as the first driver. A non-member = \$160

Make check payable to: PCA- Chicago Region

Mail to: Todd Conforti - Blackhawk Drivers' ED Registrar
553 West Carboy Road
Mount Prospect, IL 60056
(847) 382-9653 home (847) 952-0070 work
e-mail: tlcontrols@aol.com

For more information on Track Events, Schedules, Tech & Safety Requirements use the WEB at WWW.PCA-Chicago.org
For more Blackhawk information go to WWW.namotorsports.com/Tracks/Blackhawk.html.

WE GO THE DISTANCE FOR SUPERIOR SERVICE

VEHICLE MAINTENANCE & PERFORMANCE
AUDI BMW MERCEDES PORSCHE VW

KELLY MOSS MOTOR SPORTS

★ ★ ★ ★ ★



**STREET CAR
MAINTENANCE**



**RACE CAR
PREPARATION**

**TRANSPORTATION
SERVICES**



**MODIFICATION &
BUILDING**

**PAINT &
COLLISION REPAIR**



VINYL GRAPHICS



CHECK OUT OUR WEBSITE AT:

www.kellymoss.com

**3017 PERRY STREET
MADISON, WI
53713
608.274.5054**

Potter's Picnic Concours II

July 25th

The Summer Tradition
Continues At ...



POTTER'S PICNIC CONCOURS II

Peter and Janice Fischer's
24075 Chardon Road, Grayslake, IL

For 35 years families, friends, and their beautiful Porsches gathered at the Potter's lovely farm for this summer family classic. The Potter farm is gone but we continue the tradition at Peter and Janice Fischer's. AJ and Barb Tiller are our Concours hosts and Rip and Linda Patterson will host the best-ever children's games for kids of all ages!. Join us for brats, games, and Chicago Region Porsche camaraderie.

11:00 am Cars may arrive for final prep
12:30 pm First brat off the grill
1:00 pm Concours Judging begins
1:30 pm Let the games begin!
3:00pm Trophy presentation

R.S.V.P. with registration form and check to:

Checks payable to PCA Chicago Region

AJ Tiller
1828 Idlewild Lane
Homewood, IL 60430

Questions?
708.957.8262 (before 9:00 pm, please)

Class A: Exterior, Interior, Trunk, Engine & Undercarriage
Class B: Exterior, Interior, Trunk, & Engine
Class C: Exterior, Interior, & Trunk,
Class D: Exterior & Interior
Class E: Exhibition Style of Exterior & Interior - Visual Inspection Only
Novice: For fun and 1st time participants only - Judged to Class C Standards

Potter's Picnic Registration

POTTER'S PICNIC CONCOURS IS FREE TO ALL CLUB MEMBERS

Yes! I want to toss water balloons, eat brats, see beautiful Porsches, and visit with my friends!

Contact Name _____	phone _____	e-mail _____
	Pre-registered	On-site Registration
_____ Number of Adults (over 65)	@ \$ 5.00 each	@ \$ 5.00 each
_____ Number of Adults (between 18 and 64)	@ \$ 10.00 each	@ \$ 10.00 each
_____ Number of Major Kids (between 13 and 17)	@ \$ 5.00 each	@ \$ 5.00 each
_____ Number of Mini Kids (under 13)	FREE	still FREE
_____ Total Picnicers	Total enclosed \$ _____	

Concours Entrant _____	phone _____	e-mail _____
PORSCHE Model _____	Body Style _____	Year _____
Class (circle) A B C D E Novice		



Joe Rizza Porsche

The Fastest Growing Porsche Dealer In The USA.

For All Porsche Club Members...

15% OFF
ALL PARTS & LABOR!

*Special Discounted Rates
on All Scheduled Maintenance!*

Great Selection & Prices • Pre-Driven Porsche Inventory
Factory Trained & Certified Technicians • Free Service Loaner
State-of-the-Art Service Department • Porsche Parts Inventory



JOE RIZZA

PORSCHE



★ IN STOCK/IN-BOUND PORSCHEs ★

- '04 C2 Cabrio - Tip Midnight Blue/Graphite!
- '04 Boxster - 5spd Aerokit!
- '04 Boxster "S" - Tip Artic Silver/Black!
- '04 Boxster - 5spd White/Black!
- '04 Boxster - 5spd Speed Yellow/Black!
- '04 Boxster "S" - 6spd Guards Red/Graphite!
- '04 Boxster "S" - 6spd Artic Silver/Black!
- '04 911 Cabrio - Tip Blue/Graphite!
- '04 911 Cabrio - Tip Speed Yellow/Black!
- '04 911 C4S - 6spd Black/Black!
- '04 C4S Cabrio - 6spd Artic Silver/Black!
- '04 C2 Cabrio - Tip Carmon Red/Savanna!
- '04 C4S Coupe - 6spd Guards Red/Black!
- '04 C2 Coupe - "Aero" Midnight Blue/Graphite!
- '04 C4S - 6spd Seal Grey/Black!
- '03 Boxster "S" - 6spd Midnight Blue/Graphite!

GIANT SELECTION OF CAYENNES IN STOCK
**STARTING IN THE
 LOW \$40s!**

★ CALL FOR UPDATED PRE-DRIVEN INVENTORY ★

- '04 Cayenne "S" - 1K Miles \$54,500
- '04 Cayenne "S" - 8K Miles \$49,900
- '03 911 Turbo - 8K Miles \$106,900
- '03 911 Cabrio Tip - 800 Miles \$69,900
- '02 911 Coupe - 16K Miles \$58,900
- '01 911 Cabrio C4 Tip - 19K Miles INQUIRE!
- '01 911 Coupe Tip - 19K Miles \$53,900
- '01 911 Coupe Tip - 32K Miles \$52,500
- '01 Boxster "S" - 19K Miles - Aerokit \$37,900
- '01 Boxster - 19K Miles \$31,900
- '00 911 C4 Coupe 6spd - 37K Miles \$45,900
- '00 Boxster 5spd - 22K Miles \$28,900
- '95 911 C4 6spd - 53K Miles \$37,900
- '87 928 S4 Automatic - 56K Miles \$15,900

CALL: AARON ZELINSKI, TONY RIZZA,
 PAUL AMATO OR ROBERT BELCHER
 TO RESERVE YOUR CAR OVER THE PHONE!



**159th Street & 80th Avenue
 ORLAND PARK
 708-403-0300**

SHOWROOM HOURS: *Daily 9-9:30 & Saturday 9-7:30*

GO www.rizzacars.com

50 Years Of Porsche ... Then & Now

Article and pictures by Gene Bussian

April 7, 2004

"THEN" was Wednesday, April 7th, 1954. A typical Chicago spring day when I arrived from Milwaukee to take delivery of my Palm Green Porsche #51284.

Anyone reading this is quite aware of "NOW", but "THEN" requires some insight into the '50's. There were no Porsche dealers in Milwaukee. Chuck, from nearby Burlington, WI, frequented "Speedy's Cities Service" station on the west side of our town. Chuck Thiel was connected with Max Hoffman's garage in northern Chicago. It was at Speedy's that I made my first Porsche purchase.

On our first trip down, there was no car in sight. It was sold. 2nd trip down, #51399, a yellow beauty with green cord upholstery had jumped the trailer track. I was concerned with the slight visible damage and other possible hidden problems. So I passed. Chuck was understanding and patient. April 7th, we drove down to Hoffman's again and I had a choice of two. #51387 was Monde Grey with blue cord upholstery, but it had some brake fluid leaked on its top. The only choice, in my eyes, was the green 1500cc Normal.

Chuck took my Cadillac Coupe and \$2,200 as satisfaction for the \$3,500 price of the car. No sales tax, no warranty, and plates cost \$16.00.

After finally getting into my own Porsche, I turned the key, pressed the starter button ... and my life changed forever. All my preconceived ideas of heavy, long hooded, front engine cars were swept away. I was to enter a whole world of new automotive experiences and meet friends that were inconceivable to me as my Porsche as I exited Hoffman's garage. There were 84 miles on the odometer.



5/15/55 - My 1954 Porsche at Blackhawk Park Hillclimb ... Note improvised front bumper with 1955 Chevy bumper guards



4 Spyder at Wilmot in 1953



1955 at "Das Slingering" in Slinger, WI in my 1953 Green Coupe

Speedy changed my oil and filter at 233 miles and again at 986 miles!

Two weeks after delivery, I was on my way to Florida. No gas gauge ... only a wooden stick to measure your fuel. No arm rests, one plastic sun visor and it sounded like you were inside a big bass drum ... no insulation "THEN". No head rests, no lap belt, no A/C, no power anything. No side view mirrors. The bumper guards could be crushed with your bare hands. The window took about 10 turns to crank it up or down. 55 HP and 0-60 in about 12 seconds. In a hard rain, the wipers would short out and the cockpit smelled like gasoline because the reserve tank lever was just up from the accelerator. The heater knob was so difficult to pull out that you generated more warmth than you received from the hole in the frame near the wooden floorboard. Only the very high RPMs would warm the interior and defrost the windshield.

All the idiosyncrasies faded into oblivion when you drove and experienced a new feel of the road - an incredible ease of handling - the sensation in the center of your being told you that this was an intimacy with the highway never before felt.. The new feedback from the road offered you a unique control of this vehicle. We KNEW we were driving the most wonderful automobile in the world. Anything before and after the driving of our Porsches was simply waiting.

Can you imagine life without the PCA??? That too!

Competition events were run by small car clubs and the SCCA. My first competition events were without waivers, roll bars, etc. Only seat belts, helmets, tape your lights and remove hubcaps. My first race was an ice race ... and my first win.

There were 10 Porsches to follow for me. The PCA and PANO were

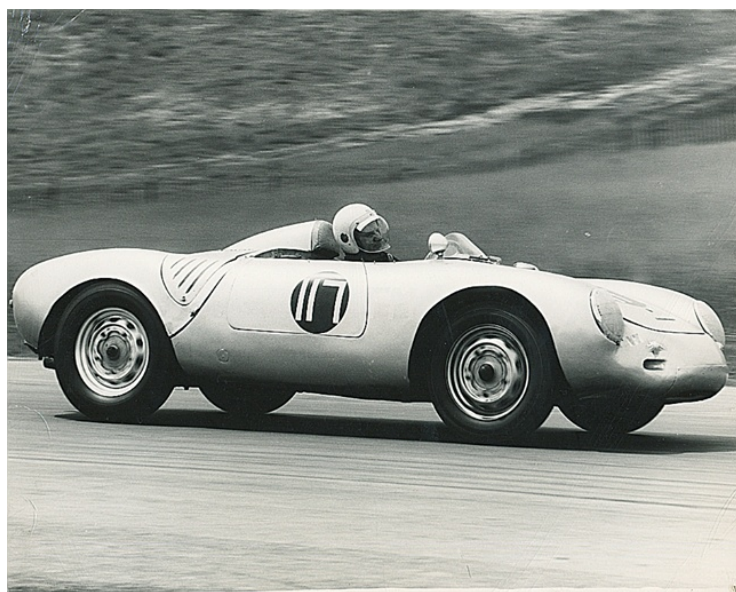

(top) At Wilmot Hills in RS 1500 in 1964
(middle) One of the most wonderful automobiles in the world!
(bottom) 7/4/55 - Milwaukee State Fair Park (#3 - '55 "Continental" 1500 N

50 Years ...

soon on the horizon. A couple of Porsche Parades came and went as did a 2 ½ day Carrera trip from Mexico City to Chicago ... before radar. Then a short stint at Zuffenhausen and later, Spyders. Time flew.

Now it is "NOW". A 2004 Cayenne S. A gas gauge, power everything, A/C, four visors, arm rests, head rests ... but alas, no spare tire! Comparing it with previous SUV's, it is really a Porsche. Great power and brakes. Only about 4,000 miles, and I have much to learn, but I would not have any other SUV.

THE CAYENNE IS AS SUPERIOR AN SUV NOW, AS THE 1500 CC NORMAL WAS SUPERIOR TO THE BEST OF THE OTHER CARS 50 YEARS AGO.

Please let me repeat what I wrote for PANO 7/87 ...

"Cars, beautiful cars, all of them. How can you explain a feeling when you can only feel a feeling? For, with all the improvements that are, and all the improvements that Porsche will come up with ... when I close my eyes and think of the cars, the picture that always returns is my original Palm Green 356 Lady or 'America' as we called it. I see it as the rare breed of its day and can still hear the sound of its motor as it speed to the horizon ... Its singular exhaust pipe creating a new sound, which we had never heard on the motoring scene - and its shape, which gave birth to forms which man had not yet conceived. Even as darkness falls, I know it is really the 356 of mine because of the two small, red tail lights which are fading into the distance as memory becomes clouded."

Thank you, Dr. Ferdinand Porsche!



The 2004 Cayenne S ... the latest Russian Porsche



Gene Bussian "THEN"

Some of Gene's "former loves" (from PANO 5/97). Gene was the first owner of all except the Spyders.

- 1954 1500 Normal 356 Coupe #51284, green/beige
- 1955 1500 Normal Continental Coupe #53403, silver
- 1956 1600S 356A Coupe, blue
- 1957 1600S 356A Coupe, silver
- 1959 1600 356A Carrera Coupe #107848, silver
- 1961 1600S 356B Coupe #115412
- 1965 912 Coupe #452161, green
- 1967 911 Targa #500575, white
- 1957 1500 RS Spyder #134
- 1958 1600 RS Spyder #139

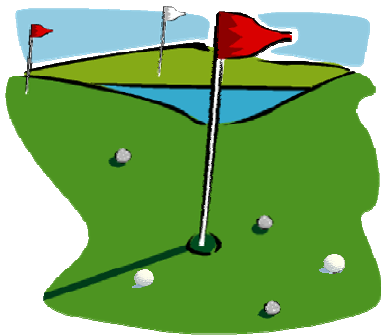

Golf Outing and Dinner

Saturday, July 31st
Flagg Creek Golf Course
Indian Head Park

Now that you have read the Scene and washed your car, it's time to get your golf clubs in concours condition as well. Why? Because the 8th **Annual PCA Golf Outing & Dinner** is just around the corner, that's why! Get those clubs out, and get them ready for the time is near to have some serious fun with them. The Chicago Region Golf Outing will be held once again at **Flagg Creek Golf Course** in Indian Head Park on **Saturday, July 31st starting at 2:00 PM**. If you have attended this event before, you know that the emphasis is on "fun" and not on "serious". If we let my wife Gayle, Nikki Pesavento, and Dan Gallagher participate, you know that having fun is the objective; and, if you play well, it's an added bonus. Once again, we have invited such luminaries as Arnold Palmer, Tiger Woods, Michael Jordan, and Mike Ditka. Come out to see if they show up after finding out that such fearsome players as Steve Shirey, Ron Micek, Pete Hackenson, and Jim Drury are likely to participate!!!

Flagg Creek is a nine-hole course with an interesting combination of holes that won't intimidate a beginner, but will challenge an experienced player trying to shoot par. However, since this outing is more about having summer fun than serious golf, the main rule is "Cheat Only If You're Sure You Won't Get Caught!". All other rules are specifically are designed to keep order, and be sure that

 **Directions:**

From the North: I-294 south to the I-55 exit. Pay toll & exit immediately at the Joliet Road option. Turn right at the 1st light(Wolf Road). One block to the course entrance.

From the South: I-294 north to I-55 south exit. Take the Wolf Road option. Right one block to the course entrance.

From Chicago: I-55 south to LaGrange Road (Rt. 45) north. LaGrange Road north to Joliet Road. Joliet Road west to Wolf Road. Wolf Road south to the golf course.

In addition to name and phone number, please circle symbol indicating how often each registrant plays or give us your handicap: N=Never Before S=Sometimes O=Often H=Handicap

Name: _____ Phone # _____ N S O H _____
 Member ___ Guest ___ of _____
 E-Mail Address _____

Name: _____ Phone # _____ N S O H _____
 Member ___ Guest ___ of _____
 E-Mail Address _____

_____ # of Registrants @ \$40.00 each \$ _____ Amount enclosed 

 Gallagher finishes last!! The event chair (myself) assigns the teams, makes the rules, and decides which foursomes will be visited by the beer cart. So be nice to me. Members wishing to bring a guest(s) will be able to play with their guest(s). The registration fee of \$40.00 covers green fees and trophies. Carts will be available for those who want them at the regular course rental rate.

This event is great fun regardless of your skill level; but, even if you can't make it for golf, please join us for dinner at Max & Erma's, just south of I-55 off County Line Road starting about 6:00PM.

Please note that our 36 openings will fill up fast, that pre-registration is mandatory; and that it closes on July 21st. This mandatory pre-registration is necessary because Flagg Creek requires a guaranteed number of players no later than one week prior to the event.

Questions? Contact me at ebarnicle@dolphincartage.com.

Make your check payable to PCA Chicago Region, and mail to:

Ed Barnicle
3 Hanover Court
Burr Ridge, IL 60527-8307



*Spend Some Quality Time
With Your Baby.*



Join the Country Club that has a race course instead of a golf course. Actually, there are three race layouts. The North Track has 10 turns and is 1.46 miles in length. The South Track has 15 turns and is 2.1 miles long with a 2000 ft straight. Combine them both and you get a 3.56 mile long course with 24 turns.

Because Autobahn Country Club has two tracks that can run simultaneously, Members will have access to the track, (North or South), that is not being rented on that day. Groups will be set on a daily basis by the Track Manager who will accommodate the different types of cars and bikes as well as driver experience. So whether you are a racer or someone who wants to learn, Autobahn Country Club is the place for you. *Drive Fast. Be Safe.*

www.autobahncountryclub.net

Call: 630-375-7652

We are located 2.5 miles west of Chicagoland Motor Speedway in Joliet, Illinois

**Scheduled
Opening Summer
2004**



**Join Now
Memberships
Are Limited!**

Tech Quiz

by Mary Anne Nowakowski

Test your knowledge on the following Porsche related questions.

Have Fun!

1) At the initial introduction of the Type 993 series in January 1994, with the exception of a more aerodynamic front and rear bodywork, over 90% of the car was actually a carryover from the Type 964 series.

True or False

2) Both the 964 based turbo 3.3 and 3.6 have a running gear similar to the Carrera 2, but the higher power, greater weight and wider track require different parts, such as the rear suspension arms.

True or False

3) Bolder wheel flares and rear wheels moved rearward identified the 1969 911 models.

True or False

4) The original 15" wheel diameter that was used in the first Porsche models was retained all the way through the 1989 model year as a stock size

True or False

5) The 964 series Carrera 2, launched as a 1990 model, was the first 911 available with a fully automatic transmission.

True or False

6) When driven in rough terrain, the Cayenne does not use the Porsche Traction System integrated as a standard feature in the power divider.

True or False

7) The traction management system on the Cayenne has a multiple-plate clutch operated by an electric motor that varies power distribution according to conditions.

True or False

8) Each 6-cylinder engine for the Boxster is completely assembled by a single, small team, and dyno-tested to check that it achieves the specified performance data.

True or False

9) The 3.2 liter engine of the 911 Carrera has a more free flowing exhaust and new heat exchangers.

True or False

10) The wheelbase for the 1982 924, 1982 924 Turbo and the 1983 944 is the same.

True or False

Answer: 1) False 2) True 3) True 4) False 5) True
6) False 7) True 8) True 9) True 10) True



Cuneo Classic Concours 2004

Pat and Bonnie Yanahan

For the fifth year the Chicago Region, PCA is organizing the prestigious Cuneo Concours d'Elegance. Held at the elegant Cuneo Estate in Vernon Hills on August 1st, this is already promising to be the biggest and best concours in Chicago recent history. Registration is ahead of last year when we had over 150 show cars representing American and European classics as well as the finest Porsches in the Midwest.

We will place the exhibiting cars around the mansion amongst the gardens and trees, allowing all entrants to have a beautiful area in which to show their cars to the other participants as well as spectators, which last year numbered over 2,000. The food tent was moved last year to a more central area, away from the show cars and our volunteers and scoring team were moved to the central air-conditioned cabana by the pool.

We have support from numerous antique and collector car clubs in the Midwest, which will allow you to see other brands of special cars. Although we are organizing the event, we are getting support and help from our friends at these different clubs. If you have friends with special cars, please tell them about this event. Be sure to register early because we are accepting registration only up to July 23rd. Please see the event announcement in this issue of the Chicago Scene for full event details.

Lots of Help Needed

We are calling for workers, runners, scorekeepers and judges. It takes over 40 people to run this event, so we are asking for help now. If you can spare just a couple of hours helping, we can make this a special event as well as have time to enjoy the show. The grounds will be open at 7:30 am and we need traffic coordinators to spot the show cars. If you are a morning person, please call us. If you and your family are coming, we could use some runners to take score sheets to the cabana. And if you are good with numbers, Bonnie and Patti could use your help with tabulation. Finally, we are looking for judges. If you are a graduate of our Concours Judges School and would like to judge cars other than Porsches, please call. Befitting the quality of the entries, final judging will be in formal attire. There will be a continental breakfast for all workers starting at 8:00 am.

And the best news is that not only are we producing a great show, the proceeds go to a children's charity of our choice.

Please contact us as early as possible.

Pat and Bonnie Yanahan
630.887.7605
pyanahan@attbi.com

Chicago's Premier Classic and Special Interest Automobile Invitational

The Cuneo Concours d' Elegance III

The Cuneo Museum & Gardens
1350 N. Milwaukee Ave., Vernon Hills, IL
Information: 847.362.3042
cuneo@lake-online.com

Sunday, August 1, 2004 - 10:00 am to 4:00 pm

The Cuneo Concours d'Elegance will be hosted by the Cuneo Museum and Gardens and the Chicago Region Porsche Club. This is the thirteenth year for this major Midwest Concours de' Elegance. The lush lawns and grounds of the Cuneo Estate showcase these automobiles of classic design and styling. This event will also include mansion tours (additional charge) and musical entertainment for our guests to enjoy. Don't forget to visit the gardens and conservatory while attending the show. A registration fee of \$20 per show car is charged. Registration will close on July 23rd. A portion of the proceeds from this event will be presented to a local children's charitable organization.



Show Car Pre-Registration Required by July 23rd, Fee \$20*
PCA questions: Pat Yanahan 630.887.7605

**Registration includes passengers in show car: all other spectators are \$5 each.
Show cars may begin arriving at 7:30 am and must be in place by 9:30 am for judging*

Please mail completed registration form and check payable to:		Concours Fee \$20 per car*	
Cuneo Museum and Gardens, 1350 North Milwaukee Avenue, Vernon Hills, IL 60061			
Name: _____			
Address: _____			
City _____	City: _____	State/Zip: _____	
Phone: (____) _____	e-mail: _____		
PORSCHE Model _____	Body style _____	Year _____	
Class A B C	D E	Novice	
Number of guests: _____			



O'HARE

auto body

The finest in auto body repair from street to full race, aero kits to custom body design, and detail work to complete paint jobs. We have superior equipment and an expert team dedicated to customer service for the distinguished auto enthusiast.

**Celette Dedicated
Fixture Bench**

**Pro Spot Resistance
Spot Welding**

Full Lifetime Warranty

**Expert Insurance
Claim Processing**

**Onsite Towing and
Rental Service**

**Certified Automotive
Restoration Technicians**

I-Car Certified

Glasurit Authorized Refinisher



**O'Hare Auto Body Ltd.
1316 W. Irving Park Road
Bensenville, IL 60106
Ph: (630) 766-6668
Fx: (630) 766-6663**

Q & A

Q: Can someone tell me why 3" belts are problem with a HANS? I just bought new 3" belts and was going to explore a HANS next.

Rob Pecori (Milwaukee Region)

A: from John Ruther ...

Most people are able to use a 3" shoulder harness with a HANS device without any problem. Every once in a while someone has a problem with the 3" belt slipping off the HANS, but it usually has more to do with the holes in the seat relative to the height of the shoulders than it does with the width of the belt. My personal experience is that a 3" belt works just fine. Most sanctioning bodies require a 3" shoulder harness so a 2" belt really isn't an option.

Schroth has just come out with a 2"/3" combination shoulder harness that has been approved by most sanctioning bodies. This belt is 2" wide where it attaches to the roll cage and stays 2" as it goes over the shoulders on top of the HANS; it then widens to 3" wide toward the bottom of the HANS and stays 3" wide to where it attaches to the camlock. This belt is the best of all worlds; it is narrow so it can't slip off the HANS as easily but it is wider to spread the load on the chest area in the event of an incident. I have not personally tried this system, but have sold many of them to customers.

How To Avoid Speeding Tickets: Part VI

Dan Metz, Potpourri, August 2002

In the Sixth and final Installment on *Driving Safely while Avoiding Speeding Tickets*, I'll give you a list of References for further reading and study.

Some of the References are hard to find, though Amazon.com is a good place to start. I've been collecting such references for > 25 years, and

cannot guarantee that some of the list below is still in print. Finally, there must be other, newer books on the market. If you know of them, let your Editor know and they can be included on future such lists.

REFERENCES

1. Smith, D. & Tomerlin, J. *Beating the Radar Rap: Tested Techniques for Fighting Electronic Speed Entrapment – and Winning*, Bonus Books, Inc., Chicago, IL, ISBN 0-933893-89-2 (1989).
2. Reynolds, M., *How to Avoid Speeding Tickets: The Fast Driver's Handbook*, New Freedom publications, no ISBN (1987).
3. Springs, D., *How to Outfox the Bears: Beating the Radar Speed*
4. Kelley, D. W., *How to Talk Your Way out of a Traffic Ticket*, CCC Publications, Los Angeles, CA, ISBN 0-918259-21-5 (1989).
5. Bello, P., *How to Win in Traffic Court: The Non-Lawyer's Guide to Successfully Defending Traffic Violations*, Major Market Books, Gibbsboro, NJ, ISBN 1-877635-38-3 (1989).
6. Rask, M. *American Autobahn: The Road to an Interstate Freeway with No Speed Limit*, Vanguard Books, Minneapolis, MN, ISBN 0-9669136-0-4 (1998). {This one will make Porsche owners cry!!}

Trap, Motorbooks International, Osceola, WI, ISBN 0-87938-274-0 (1987).

Driver's Education Auto Physical Damage Insurance

"Don't run the risk of involving your regular insurer in the event of an 'oops.' Know that you are properly covered while on track in Driver's Education events. Put a Driver's Ed insurance policy from ACI on your equipment list."

John D. Heckman

Accredited Advisor in Insurance

Driver's Education Instructor for PCA, BMWCCA, Viper Days and others

American Collectors has been providing specialty vehicle insurance to car enthusiasts since 1976. It would be our pleasure to assist you with a no-obligation rate quote.

1 (847) 253-2225

Dale Costello

www.planninghelp.com

We also provide coverage for Classic / Collectable Autos



AMERICAN COLLECTORS INSURANCE, INC.



August 7 - 8, 2004

South Haven, MI

The time is here again for our annual trek to South Haven, MI, home of GingerMan Raceway. GingerMan Raceway is a very challenging 1.88 mile road course with 11 turns, elevation changes, and LOTS of run off area. It is one of the safest track you can run.

Drivers will grouped based on experience, ability, type of car, and willingness to play nicely with others. Novices are welcome and will be assigned an instructor for the weekend. Novices should register early as their run groups always fill first.

It is the driver's responsibility to meet the requirements on the Chicago Region Technical Inspection form. All cars MUST pass tech inspection to be allowed on the track. Mandatory requirements for helmet and non-synthetic apparel are: a SNELL approved SA '95 or later helmet (date will be checked at the track), long sleeved shirt, full length pants, socks, and closed-toe shoes. Recommended, but not mandatory are drivers' suits, driving gloves and shoes all made of Nomex or similar fire-resistant materials and a fire extinguisher.

Registration and tech will be open at the track on Friday, August 6th from 4:00 p.m. - 7:00 p.m. EDT and on

Saturday August 7th from 8:00 a.m. - 11 a.m. EDT. All drivers will be required to present a valid driver's license and current PCA membership card at registration.

Race/track cars, trailers and support vehicles may be securely left at the track beginning Friday August 6th through the conclusion of the event.

There will a **MANDATORY** drivers' meeting regarding safety and policy issues for the event at the track, beginning promptly at 8:00 a.m. EDT on both Saturday and Sunday mornings. Failure to attend either meeting forfeits participation in the event with no refund.

Bring your non-driving friends and family as the South Haven resort area has shopping, beaches, family entertainment, and night life.

Registration fees include Saturday evening at the track featuring, dinner and music. Extra dinner tickets may be purchased at the event.

Directions to GingerMan Raceway: From I-94 and I-196 near Benton Harbor, Michigan, go north on I-196 for 20 miles to Exit 20 (Phoenix Road). Turn right (east) on Phoenix Road 5.5 miles to GingerMan Raceway on your left.

Year/Car Make/Model Chicago Region Permanent Car Number or if none, number requested

First Driver
 Name: _____
 Address: _____
 City, State, Zip: _____
 Phone: _____
 e-mail or Fax: _____
 PCA Member _____ Region _____
 Applicant _____ Guest of _____
 Run Group: Fastest Intermediate Slow
 Prior Experience: _____

Second Driver (same car)
 Name: _____
 Address: _____
 City, State, Zip: _____
 Phone: _____
 e-mail or Fax: _____
 PCA Member _____ Region _____
 Applicant _____ Guest of _____
 Run Group: Fastest Intermediate Slow
 Prior Experience: _____

Please include number of track days per year, professional driving schools attended, and tracks driven with typical lap times.

Questions: **Jeff Girard** 815.838.3000 dukiemaxgirard@aol.com

Mail Registration with check to: **Jeff Girard** Checks payable to: **PCA Chicago Region**
 17439 Woodbrook Lane
 Lockport, IL 60441-7416

Pre-registratrion Fees: Registrations received after August 4th or on-site, add \$10.00 per entrant
 1st Driver \$260.00
 2 Driver (same car) \$300.00 (must be family/affiliated member)

2 drivers/2 cars - complete separate registration forms (\$260.00 each)

PLACES TO STAY WHILE VISITING THE GINGERMAN RACEWAY AREA

UPDATED FOR 2004

The Chicago Region has blocks of rooms at: Old Harbor Inn, Guesthouse Inn, Hampton Inn, and Lake Bluff Hotel. You must mention that you are with PCA to secure a room in the reserved blocks.

Old Harbor Inn, Inc.
515 Williams St.
South Haven, MI 49090
269.637.8480

A Country Place Bed and Breakfast
79 North Shore Drive N
South Haven, MI 49090
269.637.5523

Oak Cove Resort
58881 48th Street
Lawrence, MI
269.674.8228 or 630.9838025

Guesthouse Inn - South Haven
72320 Phoenix Rd.
South Haven, MI 49090
269.639.9900

The Inn At HawksHead
6959 105th Ave.
South Haven, MI 49090
269.639.2146

Pigozzi's North Beach Inn
51 N. Shore Drive
South Haven, MI
269.637.6738

Hampton Inn
04299 Cecelia Drive
South Haven, MI 49090
269.639.8550

Last Resort Bed & Breakfast
86 North Shore Drive
South Haven, MI 49090
269.637.8943

Sun 'N' Sand Motel
176 N. Blue Star Hwy
South Haven, MI
(269.637.2007)

Lake Bluff Motel Inc.
76648 11th Ave.
South Haven, MI 49090
269.637.8531

Sleepy Hollow Resort
7400 North Shore Drive
South Haven, MI 49090
269.637.1127

Sunnybrook
68300 C.R. 388, (Phoenix Road)
South Haven, MI
269.637.796

Yelton Manor Bed & Breakfast
140 North Shore Drive
South Haven, MI 49090
269.637.5220

Victoria Resort B&B
241 Oak Street
South Haven, MI 49090
269.637.6414 or 800.473.7376

Vacation Place, Ltd.
410 Phoenix,
South Haven, MI
269.637.6537

Carriage House Bed & Breakfast
at the Park - 233 Dyckman
269.639.1776
at the Harbor - 118 Woodman
269.639. 2161
South Haven, MI 49090

Southview Bed & Breakfast
7019 109th at I-196
South Haven, MI 49090
269.637.2552

Americinn Inn of Douglas/Saugatuck
2905 Blue Star Highway
Douglas, MI
269.857.8581

Budget Lodge
09817 M-140
South Haven, MI
800.955.1831 or 269.637.5141

Arundel House
56 North Shore Drive
South Haven, MI 49090
269.637.4790

Michi-Mona-Mac-Cottages
337 N. Shore Drive
South Haven, MI
269.637.3003 or 847.332.1443

(Editor's note: This is, by no means, a complete listing of the accommodations in the South Haven, MI area. Other area accommodations are listed on the Gingerman Raceway and the South Haven, MI web pages.)



INK

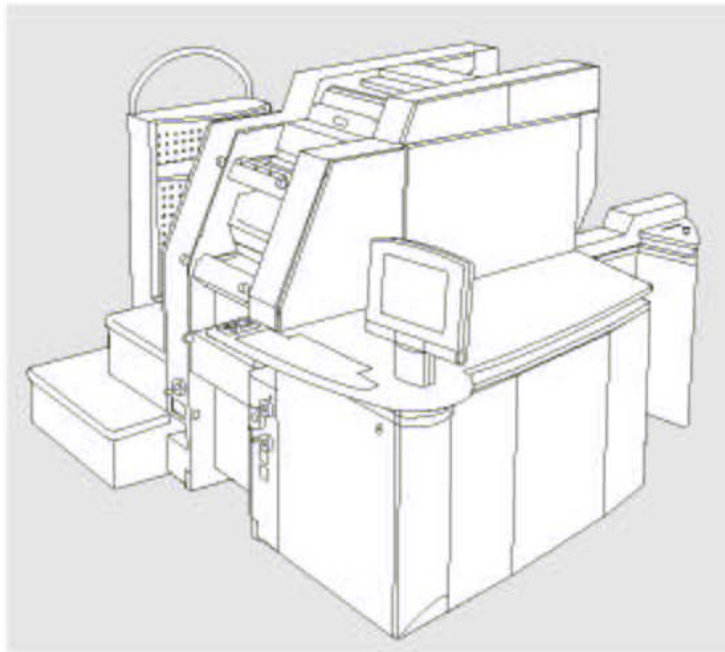

Offering the latest printing technology and experienced press technicians, we are determined to provide the best possible product – every time. This commitment to quality extends beyond paper and press to include regular reviews of the latest in ink and color technologies. At the core of any printing specification is the often overlooked ink quality and sequence. To maintain a standard of excellence, we consistently calibrate our presses to match the latest advances in inks and toners. Be it spot color, dry-trapped varnishes or 4-color process, our careful attention to detail ensures your job will stand out.

THE HEIDELBERG DI Registration on the Heidelberg DI is among the tightest of any commercial press available. This level of quality is achieved through a single gripper system that ushers each sheet through the different rollers without ever changing handlers. Direct-to-plate prepress, the tightest possible registration and the ability to print with your choice of inks are all part of our commitment to delivering the best possible product.



PRESSTech
INK. PAPER. PRIDE.

959 Lee Street • Des Plaines, Illinois 60016

P 847.824.4485 F 847.824.4775

Drive Around the Neighborhood Rallye

What could be more simple than a Sunday drive around town?



On **August 15th**, start your Rallye with coffee at **McDonald's** in Hinsdale. Not any McDonald's, but a flagship designed to replicate the neighboring historic Graue Mill on Salt Creek.

Hinsdale McDonald's is located at **935 York Road** in **Hinsdale**, just north of Ogden Ave. Please use the north parking lot adjacent to the restaurant for Rallye car staging.

- 10:30 am:** Registration opens
- 11:30 am:** Drivers Meeting
- 12.01 pm:** First car off
- 3:30 pm:** Every Club Member is welcome to join us for dinner, a Post Rallye critique and awards at McNally's Traditional Irish Pub in Elmhurst



We will Rallye our way through the beautiful tree lined streets and homes of Hinsdale, Oak Brook and Elmhurst where we will Rallye again at **McNally's Traditional Irish Pub** at 3:00 pm.

McNally's Traditional Irish Pub is located at **122 S. York Road** in downtown **Elmhurst**, just south of the Metra tracks 630.941.7100 www.mcnallysirishpubs.com



Questions: Call Jim Jacisin 630.279.4835 email: james@design-dept.com or Cindy Jacisin 708.562.6353 email: jacisiC@VANKAMPEN.com

There are opportunities available for any non-rallyists who wish to join the fun and volunteer to staff a check point ... on-the-spot training

Please make checks payable to: PCA Chicago Region and send with registration form:
c/o Jim Jacisin 508 Rex Blvd. Elmhurst, IL 60126

Rallye Fee: \$20 early registration per car.
On site Fee: \$25 with difference going to our Chicago Region Charity.

Driver: _____

Navigator _____

Phone _____ Email _____

Region _____ Member Number _____

Car Model & Color _____

SOP or Equipped _____ 1st Rallye? _____

Technical Scene

Boxster/996 Optima Battery Replacement

by Steve Grosekemper

Over the last year or so I have noticed a very high incidence of battery tray corrosion on Boxsters and 996's. I have tried to find a reason for the corrosion, such as overcharging or some other malady, but have found none. The only other reasonable explanation is that the acid vapor released by the battery is causing the corrosion. The factory installed lead-acid battery naturally expels acid vapor as it charges and discharges during its daily duties. There is a breather hose that is supposed to let the vapor escape out of the trunk area into the right fender well, but sometimes the hose will leak or fall off causing a vapor leak. Whatever the reason for this corrosion, we can definitely say that it's not desirable. What we need to do is find a way to eliminate this from happening.

The best way to avoid any battery-related corrosion is to replace the standard lead-acid battery with a completely sealed gel battery, such as an Optima battery. Optima batteries produce no acidic by-products, are lighter than some lead-acid batteries and they have an extremely high starting capacity. The one downside is that they do not easily drop into many Porsche models. Boxsters and 996s are two such models with this problem.

Fortunately, installation into one of these cars is not too difficult. The two changes that need to be made are construction of a mounting adapter and installation of a longer positive battery cable

The procedure for replacing the stock battery with an Optima battery is as follows:

- Remove the plastic pieces covering the battery and climate control particle filter.

- Disconnect the battery negative cable.
- Disconnect the battery positive cable.
- Unbolt the battery-mounting bracket on the right side of the battery.
- Remove the battery and set it aside.
- Remove the four nuts holding the battery tray in place.
- Remove the tray from the car.
- Clean the tray with a baking soda/water mixture. Paint the tray if necessary.

(NOTE: All battery components and associated hardware must be 100% free from battery acid or the corrosion we are trying to avoid will return even with a dry cell battery in place.)

At this point, we need to prepare the Optima battery for installation into the car. Due to the configuration of the bottom of the Optima battery, we need to make an adapter plate to bolt the battery in place. This piece will be made out of 1/4 inch aluminum plate measuring 6.25 x 12 inches.

To mount the plate to the car, a 3/8-inch hole needs to be drilled in one end of the plate. The hole needs to be centered on one of the 6.25 inch ends and must be 1.25 inches from the edge. (All remaining measurements will be made from this edge). Four additional holes need to be drilled (1/4 inch in diameter) to mount the battery to the plate. These holes need to be 3/8-inch from the long edge. The first set of holes will be drilled 4-3/8 inches from the edge of the plate and the second set will be drilled at 7-3/8 inches. After the four mounting holes are drilled, they must be countersunk so as not to cause any interference with the bottom of the plate and the car. (See Figure #1)

Taking four countersunk 6x30mm screws, washers and locking nuts, attach the battery to the mounting

plate. The battery positive post should be nearest the plate-mounting hole. (See Figure #2)

- Install the clean acid free battery tray back in the car. Use new locking nuts to hold it in place.
- Install the battery by setting one end of the mounting plate in the mounting clip. Then tighten down the other end of the plate with a new 8mm mounting bolt and lock washer.

You will now notice that the positive battery cable is not long enough to reach the new battery positive terminal. (See Figure #3)

To correct this situation, we need to install a longer positive cable. The new cable must be at least 24 inches long. I use a 30-inch long, 1-gage cable in this case to ensure there will be no routing or current capacity issues. The cable needs to have an eyelet on one end and a standard battery-clamping terminal on the other end.

- Place the eyelet end of the new cable in a vise and create a 45-degree bend in the connector (look at the old cable for a sample).
- Install the new positive battery cable and protection cover to the body mounted positive stud (see red arrow in figure #3).
- Attach the positive cable to the battery positive terminal.
- Reattach the original battery negative cable.

After the cables are securely tightened, the two plastic covers over the battery and climate control particle filter can be reinstalled. (See Figure #4). You now have a reliable high capacity starting battery that will not corrode battery terminal connections, body panels, or expensive electronic components.

Good Luck.

Figure #1 Notice the orientation of the plate-mounting hole as well as the countersunk battery mounting holes.



Figure #2 With the mounting plate in place, the battery will slide directly into the mounting bracket of the car.

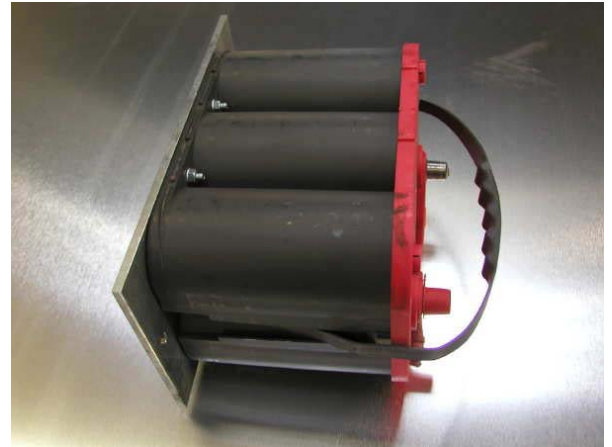

photos supplied by Steve Grosekemper

Figure #3 The red arrow shows the car end of the cable (eyelet connector). The lack of total positive cable length can be seen at the top of the battery.



Figure #4 New Optima battery installed with new, longer 1-gage positive battery cable .





Blackhawk Drivers' Education WEDNESDAY, AUGUST 18th

Here it is, the THIRD Wednesday event at Blackhawk. As you know, Blackhawk is a great road course close to home in Rockton, Illinois. Since most Blackhawk events are sell-outs, pre-register as early as possible to assure a spot. Waiting lists will be used to fill any open spots. Cancellations & refunds will be honored until 9 p.m. on the Monday prior to the event.

Mandatory clothing for all drivers at this event includes: a Snell SA 1995 or 2000 Helmet, long sleeve cotton shirt, long pants, socks, all made of non-synthetic materials, and closed toe shoes. Recommended but not mandatory are: driver's suit, driving gloves, driver shoes and a protective neck brace all made of Nomex or similar fire-resistant material, as well as a mounted fire extinguisher. Please check the date on your helmet now, as it will be inspected during the Tech Inspection at the track. **If you and your car do not pass Tech Inspection, you will not be able to drive.** You will be required to show a valid drivers license (no tickets accepted) along with a valid PCA Membership at registration.

You can save time at the track by bringing your car to a recognized Porsche Dealer or Porsche Specialty Shop for mechanical inspection and having them complete, sign and stamp the Chicago Region Tech Inspection Sheet. Review the NEW Updated Year 2004 Tech and Safety Requirements – there are changes from the prior year! Pay particular attention to specifics concerning brake pads and fluid, since Blackhawk Farms is very hard on the brake system!

Blackhawk Concession Stand serves breakfast from 9 a.m. until 10 a.m., lunch from 10 a.m. until 1:30 p.m. The Accessories Store has gas (leaded & unleaded Race only), air, and showers that are open all day.

General Event Schedule:

- 8:00 a.m. - Registration & Tech Open
- 9:00 a.m. - Mandatory Drivers' Meeting
- 4:30 p.m. - Last Car off Track

Directions From Chicago: Take I-90 west to the Rockton Road exit (about 15 miles north of Rockford.) Go west (left turn) on Rockton Road, approximately 5.5 miles and through town of Rockton to Prairie Avenue. Go north (right turn) on Prairie Avenue, approximately 1.5 miles to the track, which will be on your left.

* Mobil station 2 blocks south of Rockton Rd. on Blackhawk Blvd.

First Driver

Year/Car Make/ Model/ Permanent Car Number _____

Phone _____

E-mail _____
(circle ALL applicable) Member Non-Member Guest of: _____

Run Group: _____
[Instr/Red] [A/Black] [B1/White] [B2/Yellow] [C/Green]

Prior Experience: _____

Second Driver (same car)

Phone _____

E-mail _____
(circle ALL applicable) Member Non-Member Guest of: _____

Run Group: _____
[Instr/Red] [A/Black] [B1/White] [B2/Yellow] [C/Green]

Prior Experience: _____

Pre-registered Entrance Fees received by August 16, 2004:

Member First Driver - \$160	\$ _____
Family Member-2nd Driver - \$80 *	\$ _____
Non-Member - \$170	\$ _____
Registration received after August 16th, or On site registration add \$10	\$ _____
Total	\$ _____

* The \$80 fee only applies to 2nd family member who drives the same car as the first driver. A non-member = \$160

Make check payable to: PCA- Chicago Region

Mail to: Todd Conforti - Blackhawk Drivers' ED Registrar
553 West Carboy Road
Mount Prospect, IL 60056
(847) 382-9653 home (847) 952-0070 work
e-mail: tlcontrols@aol.com

For more information on Track Events, Schedules, Tech & Safety Requirements use the WEB at WWW.PCA-Chicago.org
For more Blackhawk information go to
WWW.namotorsports.com/Tracks/Blackhawk.html.

The Midship Report: Spring Tuneup

Article and pictures by John Miller [Boxster_S@veryspeedy.net]

Two Weekends. 2700 miles. Unknown number of cans of Mr. Pibb®. Lots of great stories and people. The Boxster season opener kicked off with a run to Hershey, Pennsylvania for the annual Porsche Swap Meet. I took the Boxster the long way, via Columbus, making a disgracefully short (90 minute) stop at the Wright-Patterson Air Force Base Museum.



Future Note: the museum itself would make an ideal weekend or even day trip in your Porsche

The Hershey event is much more than a swap meet - they have a Concours, an Autocross, road tours, social gatherings, occasionally a hill-climb, and this year, a group of 968 drivers put together a 968 reunion that attracted upwards of 40 968's

I should mention that the 968 is something of a thorn in my side. The 968 was the ultimate evolution of the 924/44 line (of which I possessed a 944 turbo) and was magnificently sorted out - ultra smooth 3.0 engine, 6 speed trans, LOTS of usable space, a backseat! and available as a Cabrio. And then Porsche killed it. In fairness, the Boxster was already in the pipeline, but comparing the 968 to the original 986 ... well, it doesn't add up. How did PAG go from a nicely refined model to a not quite cooked replacement? Porsche did figure it out and bumped displacement on the base Boxster and introduced the S - both excellent refinements of the

original, but it still stings to flip through Mart pages of Panorama and see 968's holding far more value than the beloved Boxster. End of rant; Getting back on track ... to HERSHEY!

This year, something highly unexpected occurred at Hershey. It did not rain. It almost felt like a violation of tradition. Some of the following photos capture the setting but not the excitement. Porsche car counts easily exceeded 800 (not counting the ones being taken apart in the sales area). Spectators had to be 20 or 30 times that number. Another oddity: last year, when it rained like a South Seas monsoon, there was still a good sized crowd, but the feeling was slightly different. Last year, if you were there (buying or selling), you REALLY wanted to be there. This year, along with a lot of great Porsche people, the fabulous weather brought a few posers and pretenders.

Case in point: the Boxster guy (SHAME) with 'Supercharged' emblem on the rear decklid. I approached him to ask a few

questions about it and got a few unfriendly brush-off answers. Feeling an obligation to my vast readership (all 6 of you), I gave the car a quick look-over: No extra gauges (oil pressure, boost, etc), no extra controls, no apparent add-on plumbing. So I posted a message on one of the Boxster web boards: 'Was it Supercharged?' And within 24 hours: BUSTED! He fibbed. Not only was it not supercharged, but the emblem he stuck on the back came from a Buick parts bin.

No matter, there were plenty of other fabulous cars parts and people to spend the day with. As a bonus, some Rennlisteters had put together a celebration dinner after the swap meet. Good food, great people, and remarkable Porsche stories (- like the guy with the RUF turbo - the RUF techs came to his house to do the work; and the 914 guy with the "used my shoelaces for a broken throttle cable" story ... PRICELESS!). If you're not familiar with the Rennlist, go to www.RENNLIST.org and register. Rennlist is run entirely by John Dunkle - as nice a Porsche person as you could ever meet.



Midship Report ...

John has a Chicago tie-in via our own PCA member Lee Lichtenstein. Lee and John went on an extended tour of Germany (in a Porsche, naturally) after Lee won the trip at a Porsche Parade event. At the end of our Rennlist dinner, John gave Lee a special 'award': a rare, signed designer sketch of the next generation 911 (997) from Porsche. I didn't realize the significance of this until several days later - I'm flipping through the April/May issue of Christophorus (a bit of a snooty Porsche mag that I wouldn't necessarily recommend), and staring me in the face is the very same drawing. RARE? Indeed. John had written a piece celebrating the 40th Anniversary of the Porsche 911 and was selected as one of three by Porsche North America (from nearly 140 entries) to be published and received a prize.

And while Mr. Dunkle is an unquestionably genuinely, nice person, it doesn't mean he can't wrangle a financial deal that would make Monty Hall beam with envy. Worse, it just KILLS me that I didn't think of this. John worked out a three-way trade on wheels: He found a fabulous set of alloy wheels (and tires) he wanted from one seller at the swap meet, bought them, resold them on-the-spot for a \$400 profit and then traded his wheels and tires right off his Porsche for a different set of (fabulous) alloys, and did the whole deal right there - end cost for wheels and nearly new rubber: \$500! DOH^{10!} I saw a few gorgeous sets of 10 spoke alloys that I've always wanted, but never bother to pursue because there was no way to get them home. Why in the heck didn't it occur to me to try and work out a trade? Next time!

Tune-up II (the sequel)

Since the car was prepped, I made my yearly run to Omaha. A nice little 7 hour (uninspiring) jaunt that re-enforced the limit plus 9 concept.



A 968 indeed! ... Lee Lichtenstein's 968 at the Hershey 968 Reunion.

No guarantees here, but throughout the 2700 or so miles I put on these past two weekend (99.9% of it on the interstates) up to 9 mph over the posted speed limit did not even draw a glance from the state troopers and county sheriffs. I even passed a few that were going slower. Past that 9 mph over seemed to be asking for trouble, and there were (rough guess) at least 25 drivers that I saw during these two excursions who 'Asked' and 'Received'. Again this is only relative to interstates, which I try to avoid. But when time is short, they provide the quickest, if not the most interesting route.

Extended Tune-Ups

Driving to the Hershey event meant skipping the PCA-Chicago Autocross School. This is regrettable for me (and good for those of you that I'll compete against) as there really is no better 'tune-up' for the Autocross season than this. Much like the Rallye School last month it's a great way to refresh the skills that have gone unused all winter, a good confidence builder for those with limited Autocross experience, and as a hassle-free, pressure-free event where you get to (re)familiarize yourself with your car's handling in an environment free of curbs, telephone poles, minivans, and

other assorted hazards. I haven't been entirely out of practice, though: BMW (you recall them, THE Competition) invited me to spend a couple of hours tearing up the parking lot at Arlington Park Racetrack in one of their X-3 trucks. My instructor was a guy named Rutherford. John Rutherford. From Texas. Bore a STRONG resemblance to another guy named Rutherford that will be driving the Pace Car at Indy for the 500.

I noticed a few other Porsches in the visitor parking area. I hope it was PCNA sending in 'spies' - these BMW guys get their corporate 'events' right every single time. This doesn't mean that I won't spend the few weeks scouting for BIG empty parking lots to do a little 'make-up' practice. YEOW - Look at that PCA-Chicago calendar in the magazine (that would be page 2 for those of you that skip right to the Midship Column). A few autocrosses, a couple of Blackhawk events, Road America, RallyesSOMETHING for everyone. Go to at least two or you'll be scarred for life.

Wash it! Wax it! Clay it?

Part of the spring tune-ups should always include a proper wash and wax. If you're serious and have the time, you might consider washing

the car with dishwasher detergent. This is far more extreme than a car-wash soap and will absolutely strip the existing wax off the car, which is something I prefer to do once a year ... proceed at your own risk.

It's also the right time to vacuum the Boxster from top to bottom and end to end - literally. Take a special look at the radiators (both sides plus center for S cars). These collect an amazing amount of junk that's best left undescribed. The vacuum attachments wouldn't reach the radiator fins, so I found a short length of garden hose and duct taped it to the vacuum hose and then fished it up to the radiator. I've seen some instructions posted on the web that can tell you how to take the entire front bumper cover off so that you can literally toothbrush the radiator fins, but that seemed exceptionally nuts, even for me. I've yet to, but will, take the wheels off - this is the only way to give them proper cleaning (and waxing) and you owe it to the car to do it at least twice a year.

This year I also tried the Clay bar. Clay is sometimes referred to as a paint detailer or paint cleaner. It is not for the inattentive or careless. You WILL ruin your Boxster's finish if



you don't follow the instructions and exercise caution with this product. That said, it did an exceptional job with my car. Even after a thorough wash, polish and wax, the surface of the Boxster was noticeably rough to the touch. An hour with the clay bar polished the finish to a smooth mirror-like surface. Not a bad investment for under \$20. It is available through several of the local car care product boutiques in the Chicago area as well as some of major auto parts chains (but NOT AUTOZONE, even if they tell you by phone that they carry it).

Tire Update

The Kumho® (Ecsta Supra 712's) tires are holding up exceptionally well. I've rolled up nearly 20,000 miles on them in the year that I've owned them and I estimate the rears have at least another 12,000 miles left in them. I've recommended these to other Boxster drivers and will likely buy a new set of them when the time comes. I say 'likely' because the Bridgestone S-03's are still considered the best tire money can buy for all around Boxster use. If you can afford them, get them, you won't be disappointed. ME? I just saw gasoline priced at \$2.45 and still going up. By the time I need tires, it will probably cost as much in gasoline to drive to Tire Rack® as the new tires. I'll be going with the Kumho's.

Which leads me to a nice transition: PARADE. Did you register? It may not be too late. Last year, just by virtue of attending, many PCA-Chicago members came away RICHER for the experience. And I mean in real terms - with all the raffle-drawings that take place, PCA-Chicago members came back with new sets of tires, a new Aprilia scooter, and a bunch more valuable stuff. I notice that Kumho is a sponsor at Parade. I'd be more than willing to take a set off their hands.

The Projects

Where would I find the time? The Momo race seat ... sits. I've actually sat in it a few times (in my living

room - a nice, temporary addition), but have yet to even start to figure out fitment in the Boxster.

Also in the queue, the electric cooler-warmer (for snacks and such). I did start mapping out the placement of a 12V lighter outlet in the front trunk compartment - this keeps getting more complex, involving relays and timer switches, and shielded wiring - this HAS to be ready for the trip to Ft. Worth/Parade. And the computer touch-sensitive screen for use with the GPS and to use as an MP3 Jukebox has arrived. This is a major undertaking that I need to make a priority - on both of the two recent weekend trips, I never once used the radio. Several hundred hours of music, audio books, and miscellaneous audio files in the handheld MP3 player kept me entertained and relaxed. The install will be massive enough to be a column in itself - which I hope to present here someday.

Next Month: "Are you a cab driver?" I heard this at Hershey and it took a moment to realize that it wasn't a question about ones profession. DUH. Yes, the season is here.

Maybe I can sneak away from the office and get to a mid-week Blackhawk event.

Maybe I'll have tackled some of the open Boxster projects. Ahhhhh... I just remembered ... one more tune up item: New brake pads. They aren't due (Boxsters have a sensor connected to a warning light) but heading to Texas for Parade and the Superspeedway DE - new pads are a wise investment. And a brake fluid flush wouldn't hurt either.

I need to hire an automotive caretaker.

Barrington Coach Haus

Automobile Collision and Restoration Perfection
Since 1984

BCH specializes in Porsche, Mercedes Benz, and BMW. We take pride in our workmanship from dings & dents to complete restoration and detailing. All work is guaranteed. Located approximately 7 miles west of Fischer Motors. We will come to you with our Mobile Estimating Unit.

BCH is your one stop body shop!

22073 N. Pepper Road
3 miles west of Route 59 off Route 14
Barrington, Illinois
847-382-5285

Mon - Fri: 8:00 - 4:30
Sat: By Appointment

Contact: Chuck Harley - Owner



Select Pre-Owned Sports Cars

2215 W. Belmont Avenue
Chicago, IL 60618
773.325.1690
midwestperformancecars.com



Autocross IV

August 22, 2004

LAKE GENEVA RACEWAY

- 9:00 - 10:00 am Registration and Tech
- 10:15 am Tech closed
- 10:15 am Driver's Meeting
- 10:30 am First car off
- 3:30 pm Trophy Presentation

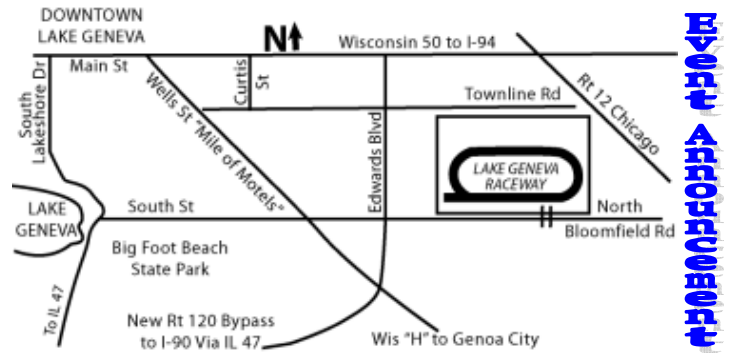

Directions to Lake Geneva Raceway

- From I-94, exit Highway 50 (Lake Geneva Exit).
- West (about 20 miles) to 3rd stoplight/"H" in Lake Geneva
- Left on H to 2nd STOP sign (Bloomfield Road)
- Left on Bloomfield for 1/2 mile to Lake Geneva Raceway

Driver #1	\$35.00 Member	\$40.00 Non-Member Guest - Member MUST be present
Driver #2	\$15.00 Family Member	\$40.00 Non-Member Guest - Member MUST be present
	\$35.00 Member sharing car with other Member	

Questions: Jeff Girard 815.838.3000 dukiemaxgirard@aol.com

GENERAL RULES: Required - Snell 1990 helmet, full-length pants, long-sleeved shirts, socks and full shoes. Member may bring one guest. Guest may drive member's Porsche or a two door sports car. Associate Member driving a non-Porsche is considered a Guest. Maximum two drivers per car. Member MUST be present with Guest. Only first car driven will trophy. Valid driver's license at Registration.

REGISTER ON-SITE please bring this completed registration form

	Member	Guest**
Driver #1 _____	_____	
_____	Phone number	
Car Model _____	Chicago Region Permanent # _____	
	Member	Guest**
Driver #2 _____	_____	
_____	Phone number	
Car Model _____	Chicago Region Permanent # _____	
** _____	Total enclosed _____	
Guest of _____	Member MUST be present	Checks payable to PCA Chicago Region



The Chicago Region's TRAC 2004

Road America in Elkhart Lake, WI

Friday, September 3rd - Monday, September 6st

12th Annual PCA Club Race Drivers' Education Concours Dinner Party

Drivers' Education - Friday, Saturday and Sunday with additional (optional) drive time on Monday. Drive time on Monday may be earned by volunteering three hours during the weekend or may be purchased for an additional fee.

Club Racers - Friday optional "Test & Tune Day", Saturday practice and Fun Race, Sunday Sprint Races, and Monday 90 minute Enduro Races.

TRAC 2004 Concours, Dinner and Party - Saturday evening, September 4th, at Siebkens Resort in Elkhart Lake.

TRAC 2004 Drivers' Education Registration form is available in the current issue of the Chicago Scene, at www.pca-chicago.org, from the registrar at 847.929.1831 or nowakowskim@permapipe.com. Drivers ED Registration is now open. Drivers ED Registration will close August 28th.

TRAC 2004 Club Race Registration form is available in the current issue of the Chicago Scene, at www.pca-chicago.org, from the registrar at 847.604.4795 or TRAC2004CR@aol.com. Club Race Registration forms may be returned to the TRAC 2004 Club Race registrar with a postmark date NO EARLIER than July 12st.

Registration confirmations for TRAC 2004 Drivers' Education and Club Race participants, the tentative TRAC 2004 Schedule, and a copy of the *Rules of Road America* will be sent via email or US-Mail. Please read the *Rules of Road* carefully before you arrive at the track to ensure that you, as well as your guests and crew, are in full compliance. All TRAC 2004 Drivers ED and Club Race participants should note that their cars cannot exceed the maximum Road America noise restriction level of 108 decibels. On August 15th the list of confirmed DE and Club Race Participants, car numbers, run groups, and any schedule updates will be posted on the Chicago Region webpage at www.pca-chicago.org.

Not driving, but still want to be part of the event? Volunteer to help and you'll have concours and dinner on us!. All TRAC 2004 participating drivers and volunteers will have their TRAC 2004 Concours registration fee waived and will be the dinner guests of the Chicago Region. Additional dinner tickets for crew and guests may be purchased via your registration form or at the event.

There will be 24-hour security at the track Thursday through Monday evening. Road America will allow participants to camp on the grounds for a fee of \$50 for motorhomes. Electrical hook-ups will also be available for \$20. These fees are payable directly to Road America. Please note that the track gates will close promptly at 7:00 PM on Monday evening and everyone must vacate the property by that time

Golf cart rentals are available again this year. Reservations must be made at least four weeks in advance of the event via your registration form. The amount listed on the registration forms is for 3-day rental of a 2-person cart. 4-seat, utility, and 4-day rentals are also available for an additional fee. Contact the Registrars via e-mail for pricing, prior to mailing in your registration. Please note that you will be responsible for any damage and a minimum age of 16 years is required to operate the carts.

Additional **TRAC 2004** information is available on the **24-hour Information Hotline at 847.604.4795**. You may also contact any of the Road America committee members between 6:00 PM and 8:00 PM CDT.

This is the best PCA event of the year so register now!

See you at **TRAC 2004 at Road America!**

Pete Hackenson
Keith Clark

TRAC 2004 Event Chairman
TRAC 2004 Event Co-chairman

The Road America Challenge 2004 Committee Members

Pete Hackenson	Event Chairman	847.604.4795	roadam.pca-chicago@comcast.net
Keith Clark	Event Co-Chairman	630.690.3381	ClarkFNFlying@aol.com
AJ Tiller	Volunteer Coordinator	708.957.8262	AJ2ManyCars@aol.com
Susan Shire	Club Race Registrar	847.604.4795	TRAC2004CR@aol.com
Mary Anne Nowakowski	Drivers ED Registrar	847.929.1831	nowakowskim@permapipe.com
John Ruther	Chief Driving Instructor	847.304.5515	chief_instructor@pca-chicago.org
Toby Duckett	Tech Coordinator	630.248.7680	Toby@mc2fyi.com
Todd Conforti	Safety Coordinator	847.382.9653	TLControls@aol.com

DRIVER MEDICAL INFORMATION for DRIVERS EDUCATION TRAC 2004
 For second driver, please photocopy this sheet, complete, and submit with event registration form

Name _____ Age _____ Birth Date _____

List any medication currently used (including eye drops) _____

Contact lenses? Y N Last tetanus shot date _____ Blood type _____

Allergies (including asthma, hay fever, medications or drugs) _____

List any current Medical Conditions _____

Describe any medical changes since your last physical _____

Physician's Name _____ Phone _____

NOTE: This information is kept confidential and is to be utilized only in the event of a medical emergency. This form will be destroyed after the event.

POLICIES: This registration form must be signed. Your signature below signifies acceptance of these policies.

- The PCA Chicago Region reserves the right to deny registration for or attendance at this event or request the removal from this event of any person as it sees fit.
- Incomplete Registration forms will not be accepted and will be returned with no registration place held. Late fees will apply.
- Road America requires that we exit the track by 7:00 pm Monday, September 6, 2004.
- The PCA Chicago Region's policy regarding fees incurred and damage caused at the track is that the party or parties responsible will be required to reimburse Road America for any fees or physical damage caused to the track, its facilities, or its equipment including (but not limited to) the clean up and removal of any spilled oil, coolant, brake fluid, discarded tires, or late exit. These are not covered in your registration fee.
- I agree to indemnify and hold harmless the organizers of this event and their agents with respect to the condition and preparation of my car or any subsequent failure or damage to my car or its occupants as a result of such failures. I acknowledge that at all times I remain solely responsible for the safety and roadworthiness of my car.
- I hereby certify that I have no known physical or mental problems which might jeopardize others or myself if I participate in this event.
- I give permission to any hospital, medical institution or physician to furnish any information necessary for treatment regarding my condition.

Signature _____ Date _____

In Case of Emergency Notify:

Name _____ Phone/cell phone/pager _____
 Relationship _____ At track? Y N At local hotel? (name) _____

DRIVERS' EDUCATION FEE SCHEDULE

TRAC 2004

	EARLY REGISTRATION <i>Postmarked by 8/6/04</i>	LATE REGISTRATION <i>Postmarked after 8/6/04</i>
First Driver		
_____ Friday, Saturday & Sunday	\$ 300.00	\$ 325.00
_____ Monday	\$ 50.00	\$ 50.00
Second Driver (family or affiliated PCA member only)		
_____ Friday, Saturday & Sunday	\$ 150.00	\$ 175.00
_____ Monday	\$ 50.00	\$ 50.00
Second Driver (non-family / non-affiliated PCA member, non-PCA member)		
_____ Friday, Saturday & Sunday	\$ 300.00	\$ 325.00
_____ Monday	\$ 75.00	\$ 75.00

NO REFUNDS FOR CANCELLATIONS AFTER AUGUST 14, 2004

A \$25.00 Processing Fee per driver will be deducted from all refunds.

CANCELLATIONS MUST BE IN WRITING

Driver(s) Fees		\$ _____
Extra shirt(s) S M L XL XXL XXXL	# _____ @ \$ 25.00 EACH	\$ _____
Extra Dinner Tickets Adult	# _____ @ \$ 25.00 EACH	\$ _____
Child (12 and under)	# _____ @ \$ 10.00 EACH	\$ _____
Golf Cart Rental* (3 day rental of 2 seat cart)	# _____ @ \$ 225.00 EACH	\$ _____
Golf Cart Rental* (3 day rental of 4 seat cart)	# _____ @ \$ 300.00 EACH	\$ _____
Make checks payable to PCA Chicago Region (No credit cards accepted) TOTAL enclosed		\$ _____

*2-day, and 4-day rentals are also available for an additional fee. Contact Registrar via email for pricing, prior to mailing in this form.

Mail this two page pre-registration form and check payable to PCA Chicago Region to:

Mary Anne Nowakowski, TRAC 2004 DE Registrar
 527 South Rammer Avenue
 Arlington Heights, IL 60004

NO REGISTRATIONS ACCEPTED AFTER AUGUST 28TH

PLACES TO STAY WHILE VISITING ROAD AMERICA IN ELKHART LAKE, WI

UPDATED FOR 2004

52 Stafford – An Irish Guest House
Plymouth, WI – 920.893.0552

The American Club
Kohler, WI – 800.344.2838

AmericInn Motel - Plymouth
Plymouth, WI – 920.892.2669
***Mention Chicago Porsche Club
for Block Reservation Rates***

AmericInn Motel/Suites
Sheboygan, WI – 920.208.8130

Baymont Hotel, Plymouth, WI.
920-893-6781 (NEW)
***Mention Chicago Porsche Club
for Block Reservation Rates***

Baymont Inns
Sheboygan, WI – 920.457.2321

Best Value Parkway Motel
Sheboygan, WI – 800.341.8000

Blue Harbor Resort
Sheboygan, WI.
866-701-2583 (NEW)
***Mention Chicago Porsche Club
for Block Reservation Rates***

Breeze Inn to the Chalet Motel
Mequon, WI – 414.241.4510

Brownstone Bed & Breakfast
Sheboygan, WI – 920.451.0644

Comfort Inn
Sheboygan, WI – 800.228.5150

Grand Hotel
Sheboygan – 920.458.1400

Harbor Winds Hotel
Sheboygan, WI – 920.452.9000

Hillwind Farm B & B
Plymouth, WI – 877.892.2199

Holiday Inn Express
Sheboygan, WI – 920.451.8700

Imperial Motel
Sheboygan, WI – 920.458.3578

Inn on Woodlake
Sheboygan, WI – 800.919.3600

Krupp Farm Homestead B&B
New Holstein, WI – 414.782.5421

Lakeland College
Howards Grove, WI – 920.565.1248

The Osthoff
Elkhart Lake, WI – 800.876.3399
***Mention Chicago Porsche Club
for Block Reservation Rates***

Pinehurst Inn
Sheboygan Falls, WI – 920.467.4314

Plymouth Inn
Plymouth, WI – 920.893.5623

Ramada Inn Downtown
Sheboygan, WI – 800.909.8770

Riverview Spa Suites
Sheboygan, WI – 920.451.9576

Rochester Inn
Sheboygan Falls, WI – 920.467.3123

Safe Harbor Inn
Fond du Lac, WI – 920.923.0223

Saukville Super 8 Motel
Saukville, WI – 414.284.9399

Select Inn Fountain Park
Sheboygan, WI – 800.909.8770

Sheboygan Super 8 Motel
Sheboygan, WI – 920.458.8080

Siebkens Resort
Elkhart Lake, WI – 920.876.2600
***Mention Chicago Porsche Club
for Block Reservation Rates***

Victorian Village
Elkhart Lake, WI – 920.876.3323
***Mention Chicago Porsche Club
for Block Reservation Rates***

Windy Mare
Kiel, WI – 920.894.2284

Wisconsin Aire Motel
Random Lake, WI – 920.994.4501

Yankee Hill Inn B & B
Plymouth, WI – 920.892.2222

Campgrounds

Cedar View Camper Rentals
Kiel, WI – 920.894.7884

Hoeft's Resort Campground
Cascade, WI – 920.626.2221

Plymouth Rock Camping Resort
Plymouth, WI – 920.892.4252

Mark & Dean's Camper Rental
Kiel, WI – 800.894.7181

Westward Ho Camp Resort
Glenbeulah, WI – 920.526.3407

Elkhart Lake Information & Booking available private Houses

Elkhart Lake Tourism Commission and the Elkhart Lake Area Chamber of Commerce

41 E. Rhine St.,
Elkhart Lake, WI 53020
920 876-2922
Toll Free - 1 877-ELKHART
elcoc@excel.net



Concours Four

Siebkens Resort, Elkhart Lake, WI

September 4, 2004

This is **THE PLACE** to begin your Labor Day Weekend ... at the **BEST PARTY** in PCA ... the **TRAC 2004 CONCOURS** held streetside at Siebkens Resort in Elkhart Lake, WI.

- 3:00 pm Concours participants may begin parking & final prep on the closed street outside Siebkens Resort
- 3:30 pm Judging begins streetside for Non-Race Car Concours Entrants
- 5:45 pm Race Cars are police escorted from Road America into Elkhart Lake
- 6:00 pm Judging begins streetside for Race Cars. Let the dinner and party begin!
- 7:00 pm Concours trophy presentation
- 9:00 pm Race Cars police escorted back to Road America. Street reopens to traffic

- Class A: Exterior, Interior, Trunk, Engine & Undercarriage
- Class B: Exterior, Interior, Trunk, & Engine
- Class C: Exterior, Interior, & Trunk,
- Class D: Exterior & Interior
- Class E: Exhibition Style of Exterior & Interior - Visual Inspection Only
- Novice: For fun and 1st time participants only - Judged to Class C Standards

Race Car Exhibition: Class for all participating PCA Club Race and Drivers ED Cars. No entry fee required.

Questions and R.S.V.P. with registration form and check to: Ron Bean 847.835.5265
 786 Vernon
 Glencoe, IL 60022

Concours Fee \$20.00 per car

Please make checks payable to PCA Chicago Region

TRAC 2004 Race & Drivers ED participants and volunteers are FREE

Concours Entrant _____ phone _____ e-mail _____

PORSCHE Model _____ Body Style _____ Year _____

Class (circle) A B C D E Novice Race/Drivers ED Car Exhibition

Participating in police escort from/to Road America? Y N



PCA CHICAGO REGION presents
TRAC 2004 CLUB RACE at Road America

September 4 - 6, 2004

Pete Hackenson - TRAC 2004 Chair
 Keith Clark - TRAC 2004 Co-chair

DO NOT WRITE IN THIS BOX Registrar Use Only	
Car Number _____	Race Group _____
Race Class _____	2 Driver car? _____
Sprint _____	Enduro _____



This event is held under the current PCA Club Racing Rules

No confirmations will be mailed. All confirmation, Orientation Meeting, and schedule information will be posted on the Chicago Region webpage www.pca-chicago.org beginning August 15, 2004. Race run group and car # information will be posted as available.

Driver's name _____ e-mail address _____

Street address _____ Evening Phone (with Area Code) _____

City, State, Zip _____ Day phone (with Area Code) _____

Shirt Size (circle) S M L XL XXL XXXL Fax (with Area Code) _____

PCA Region _____ Car # request: 1st _____

PCA Membership # _____ 2nd _____

PCA Membership Expiration date _____ 3rd _____

I am (circle) SPRINT PRIMARY DRIVER SPRINT CO-DRIVER Name of Primary Driver: _____

ENDURO PRIMARY DRIVER ENDURO CO-DRIVER Name of Primary Driver: _____

2nd Driver registered for this car? (circle) No Yes Sprint ONLY Enduro ONLY Sprint AND Enduro

2nd Driver Name _____

(2nd Driver please copy and complete this page. Please submit with Primary Driver Registration Form)

ALL Club Racing entrants must have a current PCA Club Racing License

PCA Club Racing License Status: (circle) FULL Rookie Candidate Rookie 1st Time Provisional* Provisional
 *Completed license application must be received by the Club Racing Program Coordinator's Office three weeks prior to this event

Attending Friday Night Orientation Meeting? (circle) Yes No **Rookie Candidates and 1st Time Provisionals **must** attend the Orientation Meeting.

Porsche Model _____ Year _____ PCA Club Racing Class _____

Color _____ Car Weight _____ Engine Displacement _____

(circle) Stock Prepared GT AMB Transponder # _____

Will you participate in Saturday Evening TRAC 2004 Concours Special Exhibition Class? (circle) No Yes Race car Other

RACER MEDICAL INFORMATION: This completed Medical Information must be submitted with your registration form and entry fee. You will not be permitted to register or race without this information on file with the Chicago Region Club Race Registrar. This information will be kept confidential, will be utilized ONLY in the event of a medical emergency, and will be destroyed after the event.

Age _____ Circle any that apply: Contact Lenses Diabetic Asthmatic Dentures Epileptic

Blood Type _____ Last Tetanus shot date _____

Allergies (including insect bites, hay fever, medications or drugs) _____

List any current Medications: _____

Describe any medical changes since your last PCA physical? _____

Physician's Name: _____ Phone (with Area Code) _____

In Case of Emergency, Notify: _____ Relationship: _____

Phone, cell phone (with Area Code) _____ At track (circle) YES NO Local hotel:

REGISTRATION /
 CANCELLATION

PLEASE Initial

REGISTRATIONS POSTMARKED PRIOR TO JULY 12, 2004 WILL NOT BE ACCEPTED.

\$25.00 FEE PER DRIVER FOR ALL CANCELLATIONS (MUST BE IN WRITING)

NO REFUNDS OR CANCELLATIONS AFTER AUGUST 15, 2004

PCA Chicago Region 2004 Tech Inspection Sheet

NAME: _____ DRIVER CLASS: _____ RUN GROUP: _____

MODEL/YEAR: _____ CAR COLOR: _____ ENG. DISP.: _____ CAR #: _____

Driver Classes: Green (prior C) is slowest, progressing to Yellow (prior B2), White (prior B1), Black (prior A) most experienced and faster. Red may be used as an additional identification for Instructors.

- | Pass | Fail | !!! TO BE INSPECTED BY ENTRANT PRIOR TO EVENT !!! | |
|-------|-------|--|---|
| _____ | _____ | 1. | HELMET, SNELL SA 95 or later required for all Track Events including Blackhawk, Road America, and GingerMan. (Snell SA sticker must be attached inside) |
| _____ | _____ | 1A. | HELMET, SNELL SA or M 90 or later required for all Autocross events (Snell SA or M sticker must be attached inside). Helmet Requirements! |
| _____ | _____ | 2. | APPAREL - Full-length pants, long sleeved cotton shirts, cotton socks and full coverage shoes are mandatory. Highly recommended, but not mandatory are drivers' suits, driving gloves and shoes all made of Nomex or similar fire-resistant materials. Arm restraints required for All Open Cars. |
| _____ | _____ | 3. | SEAT BELTS - Original factory installed belts for Novice, Green and Yellow. Required for all other Classes (and all Yellow/White Classes at Road America); <u>Stock Seat =6- point, "H" Harnesses without Harness Bar & no "H" with Bar or Race Seat = 5/6-Point.</u> All securely anchored, Metal-to-metal, with large diameter washers on both sides of floor mounting holes. Tunnel side belt mounting only on factory seats. Harness and Seats must be equipped the "same" for Driver and Passenger side (Instructor). |
| _____ | _____ | 4. | FIRE EXTINGUISHER - Recommended but not required. Securely anchored metal-to-metal in reach of driver. BC or ABC rated and fully charged. AFFF or Halon recommended. |
| _____ | _____ | 5. | ROLL PROTECTION - Roll Bar, Cage or Extender using "broomstick rule" Required for all A Class. The same Roll Protection is highly recommended although not required for other Classes. Any open car (no roof) must run A Class rules. Cabs must have roof in up position and sunroofs must be closed. |
| _____ | _____ | 6. | PEDALS - Free return and in good operating condition. Firm brake pedal. |
| _____ | _____ | 7. | LOOSE OBJECTS - Remove all loose items from trunk and interior, including glove compartment, door pockets, console, mats, etc. Glove box locked. Spare secured or removed (spare adds to structure to certain Porsches). |
| _____ | _____ | 8. | AIR BAG EQUIPPED CARS - No Obstructions in front of Air Bag (s). |
| _____ | _____ | 9. | WINDSHIELD - No major cracks and functional wipers with good blades. |
| _____ | _____ | 10. | MIRRORS - At least one side (two highly recommended) and one securely mounted rear view mirror. |
| _____ | _____ | 11. | GAS CAP - Gasket intact and cap tightened. |
| _____ | _____ | 12. | RUST - No rust or damage to suspension or chassis parts that affect the integrity of the chassis or brakes. |
| _____ | _____ | 13. | FRONT SUSPENSION - No excessive looseness in steering or suspension. Lower trailing arm to radius tight; Axle and shock bolt tight. Ball joints in good condition. Tie rods secure. Axle boots and oil seals in good condition. Warning: 944/968 MUST Check Ball Joint & Control Arms for cracks and binding caused by excessive lowering, larger sway bars and track usage. |
| _____ | _____ | 14. | REAR SUSPENSION - No excessive looseness. Check half shaft bolts and shock bolts. 914's check fuel pump and lines. No positive camber on any car. |
| _____ | _____ | 15. | WHEEL BEARINGS - Correct adjustment, check for play and proper lubrication, no damaged or burnt bearings. |
| _____ | _____ | 16. | BRAKES - Sufficient brake linings or pads. No rubbing, cuts or abrasions in brake lines. Check rotor condition. Brake pad thickness must be checked periodically for 2mm minimum thickness throughout the high-speed events. Make sure you start with ample brake pad material and/or bring an extra set of pads. It is recommended you start with fresh Competition pads properly bedded in. |
| _____ | _____ | 17. | WHEELS - No cracks. No bends. All lug nuts must have 94 - 96 lbs. torque. Valve stem must have airtight cap. Hubcaps and Center Caps must be removed. |
| _____ | _____ | 18. | TIRES - In Good condition. No cracks or bulges. ZR or better required (HR for Autocross only). Minimum tread depth of 3/32" on contact patch area (race tires or shaved performance tires must have as least 1/16" tread wear marker depth and No Cord Showing). Seek an experienced driver with like car/tires for hot/cold tire pressure. |
| _____ | _____ | 18. | BRAKE FLUID - Level up, must show in reservoir. All cars must have their brake systems flushed with DOT 4 specification or better brake fluid 90 days or less preceding the high-speed event. If another high-speed event is run less than 90 days prior to this event, then the fluid must be flushed again before running. |
| _____ | _____ | 20. | BATTERY (IES) - Securely fastened and in good condition. No acid leaks or corrosion. Check fuel lines under battery trays on 914's. The Positive (+) Terminal on All batteries must be covered by cap or tape. |
| _____ | _____ | 21. | ENGINE - Check for odd sounds and satisfactory exhaust (remember 108db limit at Road America) |
| _____ | _____ | 22. | DRIVE BELTS - Tight and in good condition. |
| _____ | _____ | 23. | LEAKS - No exhaust leaks and leaks of any fluid - oil, gas, brake, or coolant. |
| _____ | _____ | 24. | THROTTLE RETURN - Freely operating and good springs. Check both throttle return springs on CIS cars. |
| _____ | _____ | 25. | BRAKE LIGHTS - All bulbs on both sides and center brake light (if so equipped) must be functional. |

In consideration of my participation in this event, I have checked the above items and certify that they meet or exceed the requirements. I agree to indemnify and hold harmless the organizers of the event, or their agents, with respect to responsibility for the condition and preparation of my car, or any subsequent mechanical failures or resulting damage to my car or its occupants as a result of any such failures. I acknowledge that at all times, I remain solely responsible for the safety and roadworthiness of my car. I hereby certify that I have no physical or mental problems, which could jeopardize any others or myself if I participate in this event.

ALL OF THE ITEMS ON THIS TECH SHEET HAVE BEEN TESTED AND SERVICED AS DESCRIBED. THE TECH INSPECTOR'S SIGNATURE BELOW DOES NOT IMPLY COMPLIANCE WITH THE ABOVE AND IS ONLY AS WITNESS TO THE DRIVER'S SIGNATURE, WHICH WARRANTS COMPLIANCE.

DRIVER'S SIGNATURE: _____ DATE: _____

WITNESS TO DRIVER'S SIGNATURE (Inspector): _____ SERVICE STAMP _____ DATE: _____

Oversteer

Editor's note: Please direct your boos and hisses for the following to Bruce Janeczek as he sent it to me.

Subject: County Fair Winner

Zebediah was in the fertilized egg business. He had several hundred young layers, called pullets, and eight or ten roosters, whose job was to fertilize the eggs.

Zeb kept records, and any rooster that didn't perform well went into the soup pot and was replaced. That took an awful lot of Zeb's time; so, Zeb got a set of tiny bells and attached them to his roosters. Each bell had a different tone so that Zeb could tell, from a distance, which rooster was performing. Now he could sit on the porch and fill out an efficiency report simply by listening to the bells.

Zeb's favorite rooster was old Brewster. A very fine specimen he was, too. But on this particular morning, Zeb noticed that Brewster's bell had not rung at all!

Zeb went to investigate.

The other roosters were chasing pullets, bells a-ringing! The pullets, hearing the roosters coming, would run for cover. But, to Zeb's amazement, Brewster had his bell in his beak, so it couldn't ring. He'd sneak up on a pullet, do his job and walk on to the next one.

Zeb was so proud of Brewster that he entered him in the county fair. Brewster was an overnight sensation.

The judges not only awarded him the No Bell Piece Prize but also the Pulletsurprise.

Other Signs

from the Internet



Part Two of The Sign Says "Idiot"

Number Three

A true story out of San Francisco: A man, wanting to rob a downtown Bank of America, walked into the branch and wrote "this is a stickup Put all your money in this bag." While standing in line, waiting to give his note to the teller, he began to worry that someone had seen him write the note and might call the police before he reached the teller's window. So he left the Bank of America and crossed the street to Wells Fargo.

After waiting a few minutes in line, he handed his note to the Wells Fargo teller. She read it and, surmising from his spelling errors that he wasn't the brightest light in the harbor, told him that she could not accept his stickup note because it was written on a Bank of America deposit slip and that he would either have to fill out a Wells Fargo deposit slip or go back to Bank of America.

Looking somewhat defeated, the man said, "OK" and left. He was arrested a few minutes later, as he was waiting in line back at Bank of America!

Don't bother to give this guy a sign. He probably couldn't read it

The Mart

PCA members are welcome to place ads of a non-commercial nature at no charge in **The Mart**. The non-member, non-refundable fee for this service is \$15.00 for three months, and checks should be made payable to **PCA Chicago Region**. Ad material must be received by the 1st of the month for publication in the next month's issue, is subject to editing, and will run for three months. To be run again, after the initial three month period, ads must be resubmitted. Please limit ads to 75 words or less. Please see page 1 for submission information.

The Mart/Chicago Scene
Susan Shire
1897 Mission Hills Lane
Northbrook, IL 60062

Phone: 847.272.7764
Fax: 847.272.7785
e-mail: ChiScene@aol.com

For Sale



PORSCHE

1974 911RSR GT2R Race Car
w/new 3.8L 1998 993 RSR Sprint motor from PMNA has only 10 hrs; slantnose fiberglass wide-body/complete restoration/full cage; 935 suspension; RSR coil overs; big reds; 915 with cooler; Quaife; Mill. Spec harness; fuelcell; Fabcar shifter; aeroquip plumbing; Lexan; 16" BBS; fire system; EVO wing; full race. \$58,000/OBO. Michael Ketten, 8725 N. Seneca Road, Milwaukee, WI 53217, 414-351-5959. or MKetten@aol.com (MJJ)

1976 914 2.0 Black/white negative stripe/white interior; 110K mi; single owner since '86; repainted '87; no accidents/rust; one small dent; beautiful/excellent org example.

\$6,900. Candie 847.700.5124 or 630.497.0241 (JJA)

1976 Porsche Turbo Carrera (930)
Black/tan; very nice/clean; no accidents/maintained with open checkbook; \$22K+ invested in re-conditioning/mechanical upgrades/too many to mention; all records available. Asking \$20,500. John Olson, Omaha, NE, (w) 402-330-1010, (h) 402-392-2781 (AMJ)

1978 Porsche 911 SC Targa Silver/black interior/turbo tail; fresh Euro 3.0 eng/trans/clutch with good upgrades (Carrera tensioners, heavy case bolts, etc.); very strong/light/quick; interior/exterior very presentable, but not mint; good/affordable/drivable 911. \$10,500. Norm Chaffee 630.357.1612 (JJA)

1980 928 Coupe Pearl white/brown leather interior; 83K mi; strong eng; 5-spd manual trans; solid body/clean/no rust; sorted with new rack & pinion steering/alternator/timing belt/water pump/accessory belts/hoses/fuel injectors & pump/tires/brakes/misc relays, switches, sensors; VIN #92A0810378; service records. \$8,500/OBO Bill 773.761.7776 (JJA)

1982 924 Track Car - upgraded brakes to 944 4-wheel disc/Audi trans. Andy @ 309-370-3204 (AMJ)

1983 911SC Beige/cream/brown interior; clean/no dents; maint recors; 5 spd; sun roof; car cover/bra; exc rubber/brakes; 94K+ mi; winter storage; \$15,000. Lou Morabito Lmorabito@comcast.net or 847.736.4643, (JJA)

1989 911 Carrera Cabriolet Grand Prix white/black top/Cashmere Beige interior/white painted rims; 19,600 orig mi; "Best of the Breed" 3.2 L. w/5 speed/hydraulic clutch/electric top/spoilers/premium CD radio w/amp; factory perfect. \$32,500 Tom Spence 847.252.3622 (JJA)

1987 911 Carrera Coupe Guards Red/black; 55K mi; sunroof; F & R adj sway bars; Bilstein coil-overs; turbo tie rods; strut brace; Boxster front calipers; F & R cross-drilled rotors; front brake cooling ducts; SS brake lines; original 16" Fuchs w/ Guards Red spokes; DAS Sport roll bar; Auto authority mass flow induction; catalyst bypass; AC; Pioneer AM/FM/CD; bra & cover; new turbo clutch and top-end job @ 52k (due to valve guides); documentation of all service. \$29,500/OBO. Bill 217-872-6929 frame67@hotmail.com (AMJ)



1987 911 Carrera Guards red/black; sunroof/factory spoilers; all "power options"; exc paint; leather power "sport" seats/standard leather; Nardi/original steering wheel; Fuchs w/Bridgestone S02's; new Bilstein shocks/Blaupunkt AM/FM/CD plus original; Cover Craft cover; 2 sets of floor mats; bra/tire pump; maint by Fischer Automotive/ all records available; P21S products only; professionally tinted windows; photos available; 83K mi; \$23,900; Stan Clement 847-577-6550 or sclement@safemgt.com

1988 911 Cabriolet Black/maroon; 49,750 mi; concours ready; Weidman polished OEM rims/Yoko AVS tires like new; all new Auto Authority chip/K&N air filter; Boge shocks; sway bar bushings & rear linkages; Blaupunkt CD stereo/speakers; 12-way drivers seat/8-way passenger seat; Momo steering wheel; bra; factory window seals/horizontal & vertical; A/C recently serviced; rear window is clear; top exc cond; leather

The Mart ...

soft/scratch free; car needs nothing!
\$38,000.00 invested/ \$32,000/OBO,
Dave Leger, 630-669-1979,
drddl1@covad.net [AMJ]

1989 911 Coupe Black/cashmere;
127K mi; WPOAB0914KS120160;
Factory tail/front spoiler/power
windows/sunroof; reliable every-
day driver; exc cond inside/out;
maintained by Midwest Eurosport;
never tracked; engine needs work;
photos available via email. \$8,500.
312-252-1401 (AMJ)

1990 944 S2 Cabriolet Alpine white
/new navy blue top/interior; all
original; always garaged; newer
brakes/rotors/tires; all receipts
available; exc cond; 89K mi; pics by
e-mail. \$15,900/OBO 847.826.4657
or Lzdkng99@aol.com (JJA)

1997 911 Turbo Arena Red/gray
leather; Carbon Fiber Package/incl
steering wheel/alum dials; 23K mi;
premium sound w/CD; heated seats
w/crest; 6 speed; B&B exhaust; 18"
996 Factory turbo wheels; exc cond,
\$80,000 630.865.4357 Tony (AMJ)

1991 930 Polar Silver/black; great
cond; 59K mi, new brakes, S03's;
ABS; leather; everything works;
stock engine/suspension, 5 spd;
CD; Posi; Power Seats; Sun Roof;
\$42,000. 630-677-5647 or
bruce@graczpartners.com (MJJ)

1992 911 Turbo. Granite w/black/
tan leather; Lowered to European
specs with H&R coil overs (Rest
of car is stock); 47K mi. \$44,000.
e-mail/call for pictures/further
description. Vince 312.286.9238
vpappalardo@hlhz.com (MJJ)

1995 968 Firehawk Race Car
Meticulously prepared pro race
car from Firehawk championship
winning team/recently upgraded
by Midwest Eurosport/needs
nothing/proven winner in PCA
Club Racing E class/serious race car
looking for a home with someone
that needs a car that can run at the
front of the pack immediately; see
members.rennlist.com/tonyn/968-
forsale.htm for details and pictures.
Tony Neczet forsale@softend.com
847-722-4808. (MJJ)

1996 993 Twin Turbo, Polar
silver/black leather; 19K mi; Colgan
bra; WPOAC2994TS375343; clear
light protectors; built-in radar;
garaged; Brey-Krause harness
bar/Schroth 6 pt belts; 6 sp/4 wd;
CD/stereo; heated seats; beautiful
car/awesome performance. More
info, Bob Cavallino (d) 773.296.7820,
(e) 847.446.4692, robert.cavallino.md
@advocate.ealth.com (MJJ)

1997 993 C2S Coupe, Black/tan; 6
spd; 6 disk/CD changer; sunroof;
like new Dunlop SP8000; 32K mi;
has had dealer 30K mi service; very
clean car; College expenses force

sale. John, 847-438-7314 or
Jonbaran@comcast.net (MJJ)

1999 996/911 Coupe, Ocean Blue;
6 spd; 22K mi; clean& fast; never
raced or rallied; minimal frou-frou;
no smoke (in or out); Clean Carfax;
Options: M030/M436/P72/P77/
B-K Harness Bar with belts. Priced
to sell at \$45,450. **FREE WITH
PURCHASE**. 1996 Jeep, good
runner with spares. B Janecek at
janeczechmate@aol.com (MJJ)

2002 Boxster S Artic Silver/Black;
18,000 mi; Raised in the south/
garage kept; heated seats; sport pkg;
PSM; New job/company car leaves
little time for fun; \$42,000. 910-988-
3936 (jjaneski@aloka.com) (AMJ)

2003 Cayenne S Titanium/grey
embossed leather; 17K mi; new 3/03
from Napleton/like new cond;
comfort seats w/memory; extra set
winter floor mats/18" 5-spoke
wheels w/Pirelli snows; rear rubberized
cargo tray; 20" Sport Techno wheels
w/Michelin Diameris; \$50,000. Wm
Baker at wbakercgar@ameritech.net
or 630.235.0618 (JJA)

TIRES/PARTS/MISC

Wheels and Tires 1999 16" Boxster
factory wheels/tires Never used/
won't separate; \$2,000 for the set/
OBO. 1986 944T Phone Dial
wheels/won't separate; \$400 for

Index of Advertisers

914 Limited-----	11	Loeber Motors -----	12
American Collectors Insurance, Inc ---	47	Manny's-----	20
Autobahn Country Club-----	42	Midwest Eurosport-----	6
R A Adams Enterprises -----	5	Midwest Performance Cars -----	55
Bacino's -----	BC	MPH Technologies, Inc-----	25
Barrington Coach Haus -----	55	Napleton Porsche-----	IBC
Body Werks of Barrington-----	5	Northstar Motorsports-----	IFC
Century 21 Advisors, Inc -----	25	O'Hare Autobody -----	46
The Exchange-----	10	PressTech -----	50
Fischer Motors-----	14	R & W Performance -----	5
Forest Awards-----	32	Joe Rizza Porsche -----	36
Kelly Moss Motorsports-----	34		

the set/OBO. Steve Rashbaum
847.272.7732 (JJA)

944T Yokohama Tires 4 AVS 50i
(AV1-50i) 2=225-50-ZR16/2=245-45-ZR
16; brand new/never mounted/won't
separate; paid \$400+/asking \$300.
Dan at dantee03@sbcglobal.net (JJA)

BBS Wheels with tires very good
cond w/Bridgestone (f) 205/55/
ZR16, (r) (245/45/2R16; full polish;
center caps. Make an offer. John (w)
847.630.2037, (h) 847.541.3616. (AMJ)

73-75 911 Misc Parts torsion bar/
brake pads/lug bolts/throttle
bodies for 2 liter; gears for 901 box
(3rd and 4th); other stuff too. Offers
Ed Raymond 847.884.1070 or
eraymond@d211.org (JJA)

Parts 1977 924 rolling chassis. Spare
engines, trans, brakes, shocks,
springs, interior parts, trim, seats
and other assorted parts; MANY,
MANY sets of 4-bolt 14" + 15" rims
and 5-bolt 15" "Cookie Cutter" rims;
bolt in cage; front and rear strut bar.
Make an offer for some or all. Call
Andy @ 309-370-3204 (AMJ)

2002 911/996 Silver Front Bumper
removed when purchased to install
a "turbo" bumper/mint cond; \$375

plus shipping. Carlos 773.960.9673
carlos@segura-inc.com (JJA)

Dansk Muffler 1974 Dual inlet
Style lightly used 500 mi total;
aluminized/original box. Will take
any serious offer over \$145.00.
Proud owner pick her up in Lisle, IL.
Patrick Yanahan Jr. 630-753-9687 or
rufturbo99@sbcglobal.net (JJA)

1999 Texas Roll-Back Open Car Trailer,
16' easy loading roll-back bed
requires no ramps; 18' overall length
w/aluminum tire rack/front
mounted tool box; fits most double
bay home garages; electric brakes/
removable fenders/chrome wheels/
loading lights/plus fuel jug/spare
tire mounts under tire rack w/
enough room to accommodate small
pit bike. Orig cost \$4,700/ asking
\$2,500. Scott Lynn 630.513.0091 (JJA)

winters; classic BMW style; 198K mi.
Too many cars! Asking \$4500 to good
home. Michael 312.943.8369 (AMJ)

Denon AV Surround Sound
Receiver Model# AVR-2803/983
(Home theatre's command center);
new/never installed/have factory
specs/in a language I don't under-
stand (techno-speak); priced to sell
quickly/can be yours for 50% of
retail/\$400. Bruce Janecek 708.361.8421
or janeczechmate@aol.com (JJA)

For Rent

For Rent: Galena/Eagle Ridge
Getaway 4 BR Home 4 1/2 BA, 2
FP, 3 TV (1 plasma) w/DVDs; 3 golf
courses, bucolic countryside.
Chicago PCA member - for details,
1-800-892-2269, (unit #610) (MJJ)

OTHER

1987 BMW 325iC Convertible
2.5l straight 6; red w/black leather
interior, exc cond; new black soft
top; major Bilstein/Koni suspension
upgrades professionally installed by
Midwest Eurosport; BBS RS rims;
new clutch/starter/rotors/etc; high
end Sony stereo/CD changer; stored

Wanted

(1) Rectangular chrome RH
(passenger side) mirror to fit 75 911.
Craig Davies (630) 667-6101 (MJJ)

Advantages of driving in Germany:

1. Overall, the cars are in much better condition because of tough inspections
2. Licenses are much harder to get, with better driving training
3. The autobahn speed limit is "whatever's safe" up to 155 mph

Disadvantages of driving in Germany:

1. When you fly off the road at 120+ mph, you find out why oak was used as armor on ships

from Michael Rende



Aungahh!

Club Races. Mike Rende also send 3 articles and a picture story (I only had room for 2 of the articles).

Thanks to all who contributed to this issue.

Also in this issue you will find the registration information for GingerMan and TRAC 2004. Not only should you register early for these events, but you should make your lodging reservations PDQ.

The South Haven/Saugatuck resort area (where GingerMan is located) in MI is a very popular and fun summer vacation destination. As a result, the closer that we get to August, the harder it will be to get lodging convenient to the track and the resort area offerings. The same holds true for the Elkhart Lake area in WI over Labor Day Weekend ... fortunately we will not have lodging competition from the Harley folks this year.

Please note the correction on the Potter's Picnic registration form ... Kids at Potters are \$5.00 each.

Thanks for all the pictures Russ. As Jim notes in his column, we have lost the services of Russ Pesko as

Region Photographer to a job opportunity on the East Coast. Steve has been volunteered to step up as Region Photographer, but that doesn't mean that you shouldn't send in your event pictures. Chris Inglot covered the Autocross School for this issue and I have some pictures from another volunteer for next month's issue from one of the May Blackhawk events.

As I get this issue ready to send to Bob Soske at PressTech, it is raining, has been raining for what seems like forever, and there is enough rain in the forecast to make us consider acquiring ark plans. As you can see from the photo below, our trailer doesn't float.. I'm sure that someday, in the very far distant future, as I thumb through this issue, I'll find that picture amusing.

Thank you again Sol for hitching up (under water) your truck and hauling the trailer to higher, dryer ground.

The flooding is the 2nd in what I hope is not a series of bad car days (kinda like bad hair days). We trailered to the Mid-Ohio Club Race only to have the car break (in the 2nd lap) of the first practice session on the first day of the event. It was a very long, very quiet tow home ... but we missed the rain!

OK, so look through this issue, find an event or six that look interesting and get yourself and your car out there ... enjoy the car, the summer days, and the world renowned PCA-Chicago camaraderie.

We'll see you at an event soon!

SUSAN



A Dodge truck and Sol Synderman rescue our trailer from the flooding Des Plaines River. Fortunately, the 944 was inside the shop (Perfect Power) and not on the trailer.

photo submitted by Sol Snyderman

Aungahh (a-úun-gaaa), n. [Skip Barber Racing School]. 1 The sound of the motor of a car as the clutch is depressed, the brakes applied, and the throttle "blipped" to effect a heel and toe downshift. 2 Editors' column.

Why Would You Ever Consider A Luxurious PreOwned Vehicle From
Napleton Porsche in Westmont?

The Answer Is Quite Simple...



***It's All About
Selection.***

***The Midwest's Largest Exclusive Porsche Dealer
Finest Selection Of New And Preowned Porsches In The Midwest!***



NAPLETON
PORSCHE

201 E. Ogden Ave. • Westmont, IL • 630-725-0911 • www.ednapleton-porsche.com

Enjoy the races, visit us in Chicago!

BELLA BACINO'S

Ristorante & Pizzeria

featuring ANDRETTI WINES



- CREATIVE ITALIAN CUISINE
- FRESH SEAFOOD SPECIALS
- HOMEMADE BREADS & DESSERTS
- WINNER: AOL PIZZA POLL
- OUTDOOR CAFE SEATING
- RELAXED ATMOSPHERE
- FRIENDLY PEOPLE

WINE SPECTATOR AWARD OF EXCELLENCE

36 S. LaGrange Rd., LaGrange, IL. *** 75 E. Wacker Dr., Chicago

CHICAGO SCENE

838 Lee Street
DesPlaines IL 60018-0545