



Chicago Scene

March - April 2012



The Official Publication of the Porsche Club of America - Chicago Region

1957 - 2012 ~~~ Celebrating 55 years

INTRODUCING THE NEW NORTHSTARMOTORSPORTS.COM

Getting all the brands you trust has never been easier!

- Improved & Simplified Navigation
- New Look and Functionality
- Expanded Product Selections
- New Feature – Northstar TV (Video Features)
- Enhanced Search Functionality
- Social Networking Interactivity – Facebook, Twitter, Blog, You-Tube
- Foreign Language Translation Capability
- Improved Shopping Cart Functionality
- Smart Phone Compatibility

Northstar
MOTORSPORTS
WWW.NORTHSTARMOTORSPORTS.COM
ORDERS: 800.356.2080 | TECH: 847.304.5515



Chicago Scene

Advertisers

- 36 Autobahn Country Club
- 26 R. A. Adams Enterprises
- 23 Barrington Coach Haus
- 33 Body Works of Barrington
- 31 Century 21/1st Class - Peter Sygieda
- 3 Chicago Performance & Tuning
- 32 Clear Guard for Cars Inc
- 7 The Exchange
- 22 Fischer Motorsports
- 14 Fischer Motorsports Test & Tune, April 27th
- 8 Kurt's German Autowerks
- 31 Van A. Larson, P.C.
- 19 Laps Incorporated
- 29 LN Engineering
- 10 Loeber Motors
- 30 Loeber Motors Service
- 34 Midwest Eurosport/Eurosport Racing
- IBC Napleton Porsche
- IFC Northstar Motorsports
- 18 Perfect Power
- 24 Porsche Napleton Racing
- 13 Press Tech
- BC Joe Rizza Porsche
- 21 Sign Palace Inc
- 18 Tirebibs

Contributing to this issue: Cindy Jacisin, Ed Leed, Jim Ptak, Toby Duckett, Michael Grove, Cheryl Lehman Collier, Jim Jacisin, Jack Stephensen, Brian Beierwaltes, and Steve Rashbaum

Photographers: Steve Rashbaum and Larry Petry
ss

Features

- 35 2012 AutoX Tech Sheet
- 37 2012 DE Tech Sheet
- 11 Backroads: 1959
- 12 Backroads: 1960
- 20 14 Porsche Acronyms Explained
- 23 Chicago Region Buddy Program
- 25 How Did The Fun Start?
- 5 Let's Go, Let's Go, Let's Go!
- 8 Permanent Car Numbers
- 31 Top 10 Reasons to Rallye
- 28 Welcome to Conccours Competition
- 26 What is an Autocross?
- 27 Why Do I Like Autocross?

Departments

- 2 2012 Chicago Region Calendar
- 4 2012 Chicago Region Officers and Coordinators
- 40 Aungahh!
- 15 Board Meeting Minutes Summaries: Jan & Feb 2012
- 6 Change of Address and Contact Information Form
- 33 Membership News
- 38 The Mart

Chris Ingot, followed closely by Tom Collins, excutes a pass at the February 2012 Sebring Club Race

photo by Steve Rashbaum



PCA Chicago Region 2012 Calendar

Date	Event	Location
Apr 13	Board Meeting	VFW, Park Ridge
Apr 15	Rallye School	Perfect Power, Buffalo Grove
Apr 21	Cougars Baseball Game & Car Show	Geneva
Apr 22	Concours Judging School	The Exchange, Highland Park
Apr 29	Autocross School	Maywood Park, Maywood
May 4	Blackhawk 1 – Combined Novice & Experienced	Blackhawk Farms, South Beloit
May 6	Concours 1	Bolingbrook Promenade, Bolingbrook
May 11	Board Meeting	VFW, Park Ridge
May 12	Swap Meet	Midwest Eurosport, Bensenville
<i>May 19</i>	<i>Coffee and Cars Social</i>	<i>LaBriola Cafe, Oak Brook</i>
May 20	Autocross 1	<i>Balmoral Park, Crete</i>
May 25-27	Road America Drivers Education (RADE)	Road America, Elkhart Lake, WI
Jun 3	Rallye 1	TBD
Jun 8	Board Meeting	VFW, Park Ridge
Jun 10	Ravina Festival	Highland Park
Jun 17	Concours 2	Long Grove
Jun 24	Autocross 2	TBD
Jun 25	Autobahn 1 Drivers Education	Autobahn CC, Joliet
Jul 1	Rallye 2	TBD
Jul 6	Board Meeting	VFW, Park Ridge
Jul 8-14	Porsche Parade	Salt Lake City, UT
Jul 13	Blackhawk 2	Blackhawk Farms, South Beloit
Jul 21	Concours 3 – Potter's Picnic	Fischer's Estate, Grayslake
Jul 22	Autocross 3	TBD
Jul 28-29	GingerMan Drivers Education	GingerMan Raceway, South Haven, MI
Aug 3	Board Meeting	VFW, Park Ridge
Aug 5	Concours Charity Car Show	ABT, Glenview
Aug 10	Blackhawk 3	Blackhawk Farms, South Beloit
Aug 12	Autocross 4	TBD
Aug 18	Golf Outing	White Plains, Bensenville
Aug 19	Rallye 3	TBD
Aug 26	Concours Charity Car Show	Geneva Concours, Geneva
Aug 31-Sep 3	The Road America Challenge (TRAC)	Road America, Elkhart Lake, WI
Sep 1	Concours 4	Siebkens, Elkhart Lake, WI
Sep 7	Board Meeting	VFW, Park Ridge
Sep 9	Autocross 5	TBD
Sep 14	Blackhawk 4	Blackhawk Farms, South Beloit
Sep 16	Rallye 4	TBD
Sep 23	Concours 5	Burr Ridge Village Center, Burr Ridge
Oct 6-7	Blackhawk Oktoberfest	Blackhawk Farms, South Beloit
Oct 12	Board Meeting	VFW, Park Ridge
Oct 13	Driving Tour to WI & Social	TBD
Oct 14	Rallye 5	TBD
Oct 27	Halloween Party	Flagg Creek Golf Course, Countryside

Nov 2 Board Meeting
Nov 4 Fall Tech Session
Dec 8 Dinner Dance

VFW, Park Ridge
Midwest Performance Cars, Chicago
Butterfield Country Club, Oak Brook



Just as this image was used to recruit soldiers for World Wars I and II, we're using it to recruit you because

WE NEED YOUR HELP NOW !!!!

The Chicago Region Member Buddy Program is looking for experienced members to serve as "buddies" across all of our events - Concours, DE, Rallye, and AutoCross. Just an FYI, experienced doesn't mean you're an expert, it means you know more than someone who is brand new.

If you're interested and willing to serve as a "buddy" or you just want more info, please contact

Brian Beierwaltes

xupkid2@hotmail.com 847.404.7289

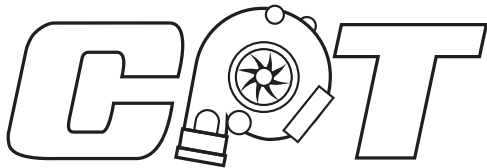

chicago performance & tuning
WHERE VICTORY IS IN THE DETAILS!

As a full service facility, CPT is proud to offer our customers an extensive line of parts and services all available in house. From minor maintenance to full race build, prep, track support and transportation, CPT is at your service. Please take a few minutes to visit www.gocpt.com for more information.

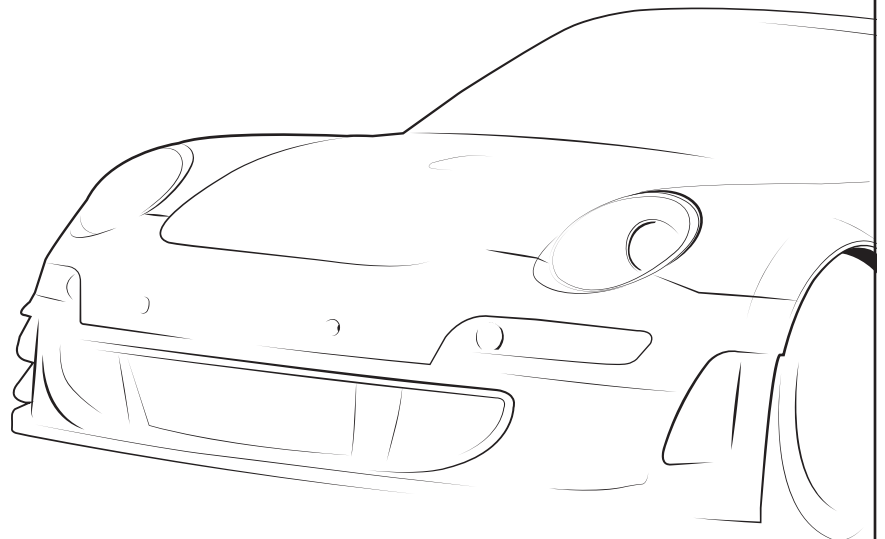

5109 Lake St. Unit B | Melrose Park, IL 60160 | 708.343.8677

2012 Chicago Region Officers

PRESIDENT

Cindy Jacisin 708.240.4757
cindyjacisin@hotmail.com

VICE PRESIDENT

Toby Duckett 630.248.7680
tobyduckett911@gmail.com

SECRETARY

Jack Stephensen 312.446.3019
jack.stephensen@e-arc.com

TREASURER

Stanley Sangdahl 630.961.1579
ssangdahl@wowway.com

PAST PRESIDENT

John Ruther 847.304.5515
john@northstarmotorsports.com

DIRECTORS

Ed Barnicle 708.302.6384
ebarnicle@comcast.net

Keith Clark 630.514.5937
kc_design@sbcglobal.net

John Diwik 630.962.9224
j.diwik@comcast.net

Kori Kwak 312.671.6789
korigirl@yahoo.com

Chuck LaMantia 847.417.6685
chuck.lamantia@msn.com

2012 Chicago Region Coordinators

AUTOCROSS

Cheryl Lehman Collier 312.402.6112
cheryl.lehmancollier@abbott.com

~ Tech

Peter Faehnrich 630.476.2267
bbrmotorsports@ymail.com

~ Timing & Scoring

Pete Bukantis 312.531.0727
pbukantis@comcast.net

BUDDY PROGRAM

Brian Beierwaltes 847.404.7289
BBeierwalter@motivequest.com

CHICAGO SCENE

Susan Shire 847.272.7764
ChiScene@aol.com

PressTech, Des Plaines, IL

Ed Soske 847.824.4485

CLUB RACE (TRAC)

Keith Clark 630.514.5937
kc_design@sbcglobal.net

~ Registrar

Susan Shire 847.272.7764
PCAClubRace@aol.com

~ Race Tech

Todd Conforti 847.254.1527
tlcontrols@aol.com

CONCOURS

John Diwik 630.962.9224
j.diwik@comcast.net

~ Co-chairs

Frank Dusek 312.332.6622
Fdusek@wsdd.com

Michael Grove 708.363.1294
mgrovecpa@comcast.net

Hank Weil 847.867.2017
Weilly@aol.com

~ Chief Concours Judge

James Jacisin 708.261.8719
jamesjacisin@mac.com

DRIVERS EDUCATION

Autobahn
Chris Inglot 847.602.9051
cinglot@aol.com

Blackhawk
Todd Conforti 847.254.1527
tlcontrols@aol.com

Pete Hackenson 8630.728.7294
phackenson@gmail.com

GingerMan

Scott Lynn 630.921.3834
ChicagoPCA@aol.com

RADE & TRAC - Road America

~ RADE Chair/TRAC Co-chair

Pete Hackenson 8630.728.7294
phackenson@gmail.com

~ TRAC Chair

Chuck LaMantia 847.417.6685
chuck.lamantia@msn.com

~ Registrars

Toby & Bonnie Duckett 630.248.7680
tobyduckett911@gmail.com

Drivers Education Tech

Peter Faehnrich 630.476.2267
bbrmotorsports@ymail.com

~ Assistant

Kori Kwak 312.671.6789
korigirl@yahoo.com

DRIVING INSTRUCTORS

~ Chief Driving Instructor

John Ruther 847.304.5515
chief_instructor@pca-chicago.org

~ Chief Novice Driving Instructor

Ed Leed 847.382.6911
leedlast@sbcglobal.net

HISTORIAN

James Jacisin 708.261.8719
jamesjacisin@mac.com

INSURANCE

Keith Clark 630.514.5937
kc_design@sbcglobal.net

MEMBERSHIP

Nicki Sangdahl 630.961.1579
nsangdahl@wowway.com

~ Membership Database

Ed and Debby Leed 847.382.6911
leedlast@sbcglobal.net

RALLYE

Steve Rashbaum 847.272.7731
steve.rashbaum@comcast.net

~ Co-chair

Ed Barnicle 708.302.6384
ebarnicle@comcast.net

SAFETY

Todd Conforti 847.254.1527
tlcontrols@aol.com

SOCIAL Co-chairs

Carl Armand 708.267.6299
carlarmand@sbcglobal.net

Carol Armand 708.267.6301
carolarmand@sbcglobal.net

SPONSORSHIP/DEALER LIAISON

Jim Ptak 224.245.0797
kingpin721@hotmail.com

TIMING & SCORING

George Schaefer III 708.562.5908

WEBMASTER

Carl Walstad
webmaster@pca-chicago.org

2012 DINNER DANCE Co-chairs

Keith Clark 630.514.5937
kc_design@sbcglobal.net

Chuck LaMantia 847.417.6685
chuck.lamantia@msn.com

ZONE 13 REPRESENTATIVE

Ken Hold 859.396.3502
kendellhold@insightbb.com

Let's Go, Let's Go, Let's Go!

Cindy Jacisin, President

Well - it's late March and the temperature has in the 70s. Is it too early in the article for me to say - Seriously, Life is Good!

That is quite a change since our first event in 2012. I know we've had a very mild winter for Chicago standards but as luck would have it, our first event was the Mix 'n Mingle on Jan 20 at Cooper's Hawk in Arlington Heights. You might remember that Friday night since it snowed about 5 inches. Thank you to Carl and Carol Armand, our Social Coordinators, who spent 2 hours creeping to the event. And thank you to the 10 local members who also attended. The event was rescheduled for March 16 and, and this time it was great turnout! Thanks to the almost 100 members who came. For several, it was their first event. I hope to see you again very soon.

Our annual Membership Meeting at Dave & Buster's was held on January 29. This is a great event that takes dozens of people to be successful. Membership Coordinator Nicki Sangdahl and Treasurer Stanley Sangdahl greeted each member and gave a mini-orientation to each new member. Carl & Carol Armand (Social), Cheryl Lehman Collier (Autocross), Steve Rashbaum (Rallye), Frank Dusek (Concours), Brian Beierwaltes (Buddy Program) and Kori Kwak (Tech and Safety) worked their respective display tables, handed out event information and answered questions in addition to giving presentations on their upcoming events. John Ruther spoke on Drivers Education and handed out several 2011 Trophies to members who missed the December Dinner Dance presentation. Thank you to all. And thanks to the 170+ members who came out. I was thrilled to see so many new members. We wouldn't do the event if it weren't for you. Now, I look forward to seeing you at the events!

Then we (me and about 200 of my closest friends) returned to Napleton Porsche in Westmont on February

19 for our 22nd Annual Concours School and Chili Tasting. Thanks to John Diwik for chairing the event. As usual Ron Bean, James Jacisin and Pat Yanahan demonstrated their techniques. Members learned how to care for their car's interior, exterior, chassis and engine - to return it to a new car appearance. Well, given the instructors' national reputation for excellence, cars will look better than brand new. John and Michael Grove developed an "Introduction to Concours" class attended by about 30 people. Great idea!

Then there was the food! Twenty-three, yes 23, chilis prepared by our local chefs fed our hungry members. Prizes were awarded for chili - Beaniest, Hottest, Meatiest, Tomatoiest, and Veggiest. Then my favorite part - desserts. A cake in the shape of a 911, a Road America cake (I ate both the chocolate and the yellow cake sides), a Porsche crest-shaped cookie, chocolate in the shape of Porsches and more. And I enjoyed them all. I'm sure the judges received enough teasing so I'll simply say - well done.

Congratulations to all the kids who participated in the remote control car autocross and mini-concours. Thanks to Beth Luddy, Barb Stark and Karen Morse who worked registration. Again, this is an event that takes quite a few people to organize and most of those people as well as Tom Stark, Bonnie Yanahan, Patty Jacisin, Bob Rath, Jim Drury and Lisa Barthels helped set up Saturday evening and clean-up Sunday afternoon. Great job everyone.

Thanks again to Napleton Porsche Westmont and Ron Barnaba for allowing us to use your dealership. And thanks to Carey Terlep and the Napleton crew who gave up their Sunday. Goodie bags were courtesy of Emmons Coachworks and Griot's Garage. As always, it is greatly appreciated.

Our annual Spring Safety Tech Session returned to Northstar Motorsports.



Thanks for John Ruther, our Chief Driving Instructor and Immediate Past President, Jeannie Ruther and their staff for opening their store on a Sunday (and thanks for the discounts). Over 100 attendees learned how to prepare their cars and their equipment for the upcoming Drivers Education (DE) and Autocross season. Thanks to OMP for making a presentation on their newest racing gear and safety equipment and for raffling many of their products. Peter Faehnrich and Kori Kwak performed a mock tech inspection and reviewed the tech sheets so drivers know what to expect at a DE or Autocross event.

April brings:

Rallye School - Learn what a rallye is or fine tune your rallye skills. The session starts with a rallye school, then has participants drive a short road rallye before meeting at a restaurant to discuss the route and the instructions. Great event for first time rallyists!

Kane County Cougars Baseball and Car Show - \$28 for a ball game, unlimited food on a private patio, a visit with Ozzie the mascot and the opportunity to run the bases. Do I see a holiday card opportunity??? Parking for Porsches is paved and right near our gate so it couldn't be easier. Skybox seating is available if there is inclement weather.

Zone Concours Judging School - Learn how to judge the car to Parade standards and to our region concours standards. Great session to attend to learn how to judge a car and to learn how your car is judged. I encourage all current concours judges and concours entrants to attend this session.

Autocross School - Learn what an autocross is and how the skills learned will make you a better driver. After a classroom session, apply what you learned on handling your car through a slalom, skid pad and braking zone. Great event for all members. Recommended for novice drivers who want to drive Road America over Memorial Day Weekend.

May will bring:

Blackhawk 1 Novice and Experienced Day - This event is dedicated to the novice driver to learn how to handle your car on the track amongst your peers. Recommended for novice drivers who want to drive Road America over Memorial Day Weekend.

Concours 1 - Our 3rd trip back to the Promenade Mall in Bolingbrook. Swap Meet - Participate as a buyer or a seller at Midwest Eurosport in Bensenville.

Cars 'n Coffee - New this year - Meet

us on a Saturday morning for casual conversations over a pastry at Labriola Cafe in Oak Brook.

Autocross 1 - Our 2nd trip back to Balmoral Park to use every inch of their gigantic parking lot.

Road America Drivers Education (Memorial Day Weekend) - New this year - 3 days of driving for experienced drivers. Same fun and camaraderie for the entire family.

Don't forget to register for our Driver's Education events (Blackhawk, Autobahn, GingerMan and Road America) on <http://register.pca.org>

Please review our website, under Drivers Ed, for information on the HPDE Insurance Program. The program provides affordable, single event physical damage insurance for vehicles used in PCA high-performance driving schools.

Porsche Parade Registration opened March 27. Come join us in Salt Lake City on July 8-14. It's a week long celebration of all things Porsche. Events include a judged concours and a non-judged corral, rallye, autocross, driving tours, a golf outing, kids activities, banquets and my personal favorite - the

ice cream social. A great event for the entire family.

The Board of Directors has selected Toys for Tots to be the 2012 Chicago Region Charity. Thank you to the charities who presented in February and March. We appreciate your involvement and dedication to your respective charities. Thanks to the Sangdahl's efforts at the General Membership Meeting, the Club has already raised \$650.

I must admit, the most frequent comment I've heard concerning the e-mail blasts is, "Thanks for the name tag reminder". I should have taken my own advice but yet I went to the Concours Chili Tasting Event and had to wear the big 'ole sticker name tag. So please do as I say - not as I do. Lesson learned.

Not getting the monthly blasts on upcoming events? Go to www.pca.org, sign in, and add your e-mail address to your profile. Family affiliates and associate members can receive them too! If you are having trouble, e-mail me at cindyjacisin@hotmail.com

Please continue to check the website for event details and I hope to see you at an upcoming event.

CHANGE OF ADDRESS and CONTACT INFORMATION

Names(s) _____

PCA Membership #(s) _____

Old Address _____

NEW ADDRESS _____

Home/Cell Phone _____ **Work Phone** _____

e-mail address _____

Send to: Debby Leed, 37 Lakeview Drive, Barrington, IL 60010-1949 or Leedlast@sbcglobal.net



Front Right – Bob Maguire, winner; Back Row Left to Right – Todd Ford, The Children’s Heart Foundation Illinois Chapter President; Bruce Semersky, General Manager of The Porsche Exchange and Vice President of Semersky Enterprises; Leo Cole, Event Chairman; Mark Witzke, Golf Invite Insurance

Golfer Wins A New Porsche From The Porsche Exchange

With one swing of his 4-iron Bob Maguire sank a hole-in-one, and won a new 2012 Porsche Cayman R from The Porsche Exchange in Highland Park.

His 175-yard shot on the second hole at Conway Farms Golf Club in Lake Forest during The Children’s Heart Foundation Golf Outing netted him every golfer’s dream, and a new Porsche from The Porsche Exchange.

Bruce Semersky, vice president of Semersky Enterprises and General Manager of The Porsche Exchange said he was “delighted for Maguire. One good drive deserves another, and the Cayman is a great car,” Semersky said.

“Any time we can support a charity as worthy as The Children’s Heart Foundation, we’re honored,” Semersky said. “Everyone at The Porsche Exchange was excited when Bob came in to get his keys, but of course Bob was the most excited of all.”

Bill Foley is the Executive Director of The Children’s Heart Foundation. Todd Ford is the Illinois Chapter President and Leo Cole served as Event Chairman. Mark Witzke of Golf Invite provided the insurance for the hole-in-one.

THE EXCHANGE
A Division of Semersky Enterprises, Inc.

2300 Skokie Valley Rd.
Highland Park, IL 60035
www.4porsche.com



Permanent Car Numbers

Ed Leed, Membership Database and Chief Novice Driving Instructor

It's time to get ready for the 2012 season. Chicago Region has over a dozen Autocross and Driver Education events scheduled this year, so if you do not have a permanent number for your Porsche, here is how to get one. You will need a permanent number because it simplifies everything, from registering for our events to timing and scoring. We have banned numbers painted with shoe polish, so now you get to decorate your Porsche with vinyl numbers that our corner workers can actually read.

Although the Autocross or Driver Education registrar may have given you a temporary number last year, it is not your permanent number. Another member may already own the number you are temporarily using and will likely be disappointed to see his number on your car at a future event. If you plan to regularly enter Chicago Region autocross and track events, you will need a number permanently assigned to you.

You will also need a permanent number in order to use the online registration system. Be aware that the online registration site is not directly linked to our master Chicago Region Permanent Number list. Therefore, the online registration system may show a number as available at the time you complete the online form and may accept the number that you enter, but the registrar will confirm it or assign you a different, temporary number. So the trick to avoid this confusion is to have your own permanent number. If you already have been assigned a Chicago Region Permanent Number, simply enter it into the online registration form. If your permanent number has been hijacked by another entrant, enter a different number and

notify the registrar. The registrar will straighten it out. Hint: Enter our events early to avoid conflicts about car numbers.

The list accompanying this article displays the numbers that are available. If you previously have been issued a number and see it on this list, it is because our records show that you have not entered an event for the past two years and the number has been released. Contact me immediately if you want to keep it. If I do not hear from you by June 1st, it will be reassigned to the first person requesting it.

Very few two digit numbers are available. Due to their scarcity, two digit numbers are awarded to members who frequently enter, volunteer and chair our events. If you would like to add your name to the waiting list for a two digit numbers, please let me know.

In order to keep your permanent number, you must use your assigned number at least twice over a two-year period at a Chicago Region Autocross, Driver Education or Club Race event

To request a number, please email me your list of three to five choices in preference order. You will need a number for each person who will drive the car at an event. Remember to include the year and model Porsche that the number will be used for. Numbers are assigned on a first come, first served basis.

Please email your car number request, Porsche year and model to me at Leedlast@sbcglobal.net. Again, don't forget to include the year and model of your Porsche.

Kurt's German Autowerks

Your Dealer Alternative for Full Service Repair

Porsche Premier
Audi Master Tech

Major Overhauls
Engines
Transmissions
Balancing
Chassis Setup
Track Prep
PCA Club Racing
Routine Maintenance
Pre-Race Inspections
Electrical System - All Phases

PREMIER Technician

Call Today: Master Guild Technician Since 2002

13850 Parker Road
Homer Glen, IL 60491
Mon.-Fri. 8-6 • Sat. 8-5

708-301-2910 or 708-431-6130



Permanent Car Numbers				
Available Numbers				
<u>100-200</u>	<u>300-399:</u>	<u>500-599:</u>	<u>700-799:</u>	<u>900-999:</u>
135	303	507	702	923
142	317	521	708	925
145	323	532	718	927
147	334	534-539	722	931
149	340-342	540	731-734	937-938
154	346-348	542-544	739-763	940
164	350-354	546-549	765	942-943
172	364	553	769-775	945-948
182	368-370	560-563	778-781	950
184	372-374	565-566	783-786	952
186	376	568-569	789	954
	378	573-574	791-794	958
<u>200-299:</u>	380-381	577-579	798	960
204	383-392	582-586		967
206	394-399	589-598		972-975
210				978-979
216-217	<u>400-499:</u>	<u>600-699:</u>	<u>800-899:</u>	981-985
227	401-403	Note:	812	987
230	406	600 to 655 are	816	992
233	412-413	Reserved for	822	994-995
235	416	Temporary Use	825	
243	422	For Entrants Who	830	
245	432-436	Do Not Have A	832	
247	438-439	Permanent Number	834-837	
249	445	At Autocross &	839	
251-252	447	DE Events	841	
254	450	These Numbers Are	843-844	
256	453	Not Assigned As	846-848	
261	457-458	Permanent Numbers	850	
264	460		852-854	
258-260	462-463	Available:	857-861	
263	467-468	657-658	863-865	
266-267	470-473	672	869-876	
273	478-488	674-675	878-879	
276	493-495	678-679	882-884	
279	497-499	681-688	886	
284		691-693	889-897	
287-288				
291				
294				
298-299				



LOEBER

MOTORS

EXPERIENCE THE
ALL-NEW
Porsche 911



*We at Loeber Motors believe...
Nothing should ever get
between you, and the road.*

LOEBERMOTORS.COM

ONLY IN LINCOLNWOOD, IL

THE LARGEST PORSCHE SALES AND SERVICE FACILITY IN THE MIDWEST

Search our new and certified pre-owned selection of Porsche vehicles online at www.loebermotors.com
Loeber Motors | 7101 N. Lincoln Avenue | Lincolnwood, IL [888] 575.9556

Backroads: 1959

Jim Jacisin, Historian

A somewhat familiar view of the pit lane grid from Road America, in Elkhart Lake Wisconsin in 1974.

This photo from longtime members Bruce and Jean Janecek.

*“From the **REALLY GOOD** old days. Before the the pit roofs blew away and there was a smell of shoe polish and race fuel in the late summer air.”*

And while the cars might still be recognizable, the track was beginning a transition to its present day configurations.

Lost to the growing demands for driver and spectator safety as well to the business of modern professional racing and sponsorship.

PCA Chicago: since 1957

In 1974: (MCMLXXIV)

Porsche 911 Turbo, the Type 930 is introduced

55 MPH national speed limit is imposed

Sears Tower becomes worlds tallest building

Global recession deepens

Richard Nixon is forced to resign in Watergate scandal

MRI Scanners are invented

Pocket Calculators begin to appear in stores

In Sports:

Oakland A's d. Los Angeles Dodgers in World Series

Emmerson Fittipaldi is Formula 1 world champion

Johnny Rutherford wins Indianapolis 500

In Movies:

The Sting, Blazing Saddles, The Godfather II

In Music:

ABBA, David Bowie, Alice Cooper, Supertramp

Year End Dow Jones Industrial Average: 616

Unemployment Rate: 4.9%

Inflation: 13.9%

Medium household income: \$11,900

Average home price: \$36,000

Postage stamp: \$.08

Gas: \$.53

Bread: \$.24

Milk: \$1.57

Eggs: \$.78



Backroads: 1960

Jim Jacisin, Historian

This memory from long time member Larry Petry:

Fifty-Two years ago this Oct. 27th, my father and I drove to Chicago to check out the two Porsche 356B Roadsters for sale in the area. At the time, there were 4 dealers that advertised in the Chicago papers. After phone calls to all four, two of dealers had one new Roadster.

One was at South Import Motors at 71st and Stony Island, the other was at Loop Import Motors on Wacker near Michigan Ave.

We looked at the one at South Import first, then went downtown to Loop Import next.

After looking at both Roadsters, I decided to buy the one from South Import Motors because I really didn't want to drive to the downtown area for service. Being from a small farming community 100 miles south of Chicago, I had never seen a building like the one that housed South Import Motors.

I can't remember how many floors the building had but everything above the ground floor was like a parking garage that housed their inventory.

The only way that cars could get from floor to floor was via a one lane corkscrew drive. Needless to say, car horns were honking quite a bit.

The Roadster I bought was on the second floor if I remember right. Anyway, that's where my love affair with Porsche cars began 52 years ago.

PCA Chicago. Since 1957

In 1960: (MCMLX)

Rear engined & aircooled, the Corvair debuts. The Flintstones, Andy Griffith, and Route 66 debut.

Nuclear submarine USS Triton completes first underwater circumnavigation of earth.

A pizza parlor in Detroit is renamed Domino's.

John F. Kennedy elected president.

In Sports:

Pittsburgh Pirates d. NY Yankees in World Series.

Jack Brabham is Formula 1 world champion.

Jim Rathmann wins Indianapolis 500.

In Movies:

Psycho terrifies movie goers, Ben-Hur wins Oscar

In Music:

Come Dance With Me and Mack The Knife

90% of homes in U.S. now have televisions

Unemployment Rate: 5.5%

Inflation: 1.4%

Medium household income: \$11,900

Average home price: \$16,500

Average new car price: \$2,275

Postage stamp: \$.04

Gas: \$.31

Bread: \$.24

Milk: \$.47

Eggs: \$.57





The picture on the opposite page was taken at the 2002 356 Registry East Cost Holiday in Charleston, SC. The ECH is just a long weekend event with a People's Choice Councours the last day. I was waiting in line at the left field wall at a minor league baseball stadium in Charleston to receive my "B" open ribbon for 3rd place. Dinner that night was there too.

This photo was taken at Mid America Motor Works in Effingham, IL. At the time, they sold parts for Porsche, VW and Corvette and had an annual summer weekend event called Funfest for each make. Each event had several sort of VIP's walk through the parking area and pick out a car they liked best rewarding that car with a trophy. The president/owner of the company, Mike Yeager always liked my car and awarded me with the President's Choice award one summer which gave me the opportunity to display my car in his museum the following year. Unfortunately, they discontinued Porsche parts.

text and photos by Larry Petry

PRESSTECH has your printing needs covered...



Give us a call and we will find the **best** and most **cost effective** solution.

www.presstechus.com



PRESSTECH

COMPLETE FULL-SERVICE PRINTING
+ DIRECT MAIL

959 Lee Street, Des Plaines, IL 60016 • 847-824-4485

PRODUCTS

- Banners
- Booklets
- Brochures
- Business Cards
- Calendars
- Catalog Sheets
- CD Duplicating
- Directories
- Direct Mail
- Envelopes
- Handbooks
- Labels
- Letterhead
- Magazines
- Manuals
- Postcards
- Posters
- Presentation Folders

SERVICES

- Graphic Design
- Typesetting
- Digital Color Copying
- High Speed Digital Black & White Copying
- 1-2 Color Printing
- Full Color Commercial Printing
- In-house Bindery
- Mailing Services
- Direct Mail
- Large Format Signage

ADVERTISEMENT - Not a PCA Chicago Region Driving Event

Test & Tune 2012

**Gingerman Raceway
April 27th, 9.00am - 5.00pm**

Admission: \$200.00

Info: 847.304.8822

**FISCHER
MOTORSPORTS**

Board Meeting Minutes Summary

Respectfully Submitted by JackStephensen, Secretary

Porsche Club of America Chicago Region Board Meeting Minutes January 06, 2012

Voting Members Present: Cindy Jacisin, Toby Duckett, Stanley Sangdahl, Jack Stephensen, John Ruther, Ed Barnicle, Keith Clark, John Diwik, Kori Kwak, and Chuck LaMantia

Coordinators Present: Scott Lynn, James Jacisin, Cheryl Lehman Collier, Todd Conforti, Chris Inglot, Nicki Sangdahl, Peter Faehnrich, Peter Hackenson, Jim Ptak, and Carl Walstead

Members and Guests Present: Patrick Yanahan, Sharon Ptak, and Wesley Dunford

President's Report: A quorum being present, Cindy Jacisin called the meeting to order at 8:01 p.m. at the Park Ridge VFW Hall, Park Ridge, IL.

Secretary's Report: Keith Clark motions to approve the minutes of the last meeting as submitted by Todd Conforti. Motion approved

Treasurer's Report: Stanley Sangdahl handed out a detailed accounting of the completed financials for year. He then presented two new forms to be used by Event Coordinators. These forms are to be used for reporting income and expenses to improve the accounting for events. He also requested that Coordinators submit any cash received at events directly to him, if he is present at the event. Motion Approved

President's Report: Cindy Jacisin welcomes everyone to the 55th year of the Chicago Region. John Ruther reports that he will bring the unclaimed trophies from the Dinner Dance to the Membership Meeting. Cindy Jacisin discusses the Post Event Report and the Observers Report which are national forms that are to be completed after every event that requires insurance. Cindy then begins a discussion

regarding the Email distribution lists that are used and held by several coordinators. A discussion follows regarding the appropriateness of the use of these lists. It is decided that the Officers and Directors need to be included on any email being sent out by a coordinator. It is also recommended that the President should be the main source of general email announcements using the email service provided at the national Website.

Vice President's Report: Toby Duckett - no report.

Autocross Report: Cheryl Lehman Collier is still finalizing the locations for the autocrosses for this year. Possible locations are Sugar River Go-Kart Track, Balmoral Park, Autobahn Country Club, and the TireRack. Cheryl is also working on lowering the cost of trophies for this year. Cheryl also reported there is a possibility of L&N Engineering sponsoring the autocross program for the year. Chuck LaMantia begins a discussion about the need to formalize the logo for this year as it is the 55th anniversary of the club.
Autocross School: Cindy Jacisin reports that Ed Leed has the date reserved at Maywood Race Track.

Timing & Scoring Report: Cindy Jacisin reports for Pete Bukantis that we have equipment and it will be ready for the start of the season.

Road America Report: Cindy Jacisin announces that Keith is the lead for Road America for this year and requests that Keith review the pricing for all the DE Events for the year. Keith Clark reports that a probable increase for track rental at Road America will be coming. The contracts are still being held by Road America and he is still in discussion with them.

Blackhawk Farms Report: Todd Conforti reports that we do have contracts for Blackhawk. The daily track rental rate went up and many improvements have been made at the track. In light of this, the Octoberfest

dinner might be held right at the track. The pavilion is now enclosed and heated. Todd is still working on pricing and still exploring sponsorship opportunities. Contracts will be given to Stanley Sangdahl to pay.

GingerMan Report: Scott Lynn reports we have a contract for GINGERMAN. He also reports that there is once again, no increase in the track rental fee. The rate will remain the same per day. He also states that they need the deposit by end of month.

Autobahn Report: Chris Inglot reports that he has the contract for Autobahn. The rental cost for Autobahn will remain the same for this year. The contract has been given to Stanley Sangdahl to mail in with the deposit check.

Chief Driving Instructor' Report: John Ruther reports that he will need Instructor Certificates printed and Ed Soske will be contacted.

Insurance Report: Keith Clark presents a detailed hand-out on Club Insurance for the upcoming year. He stresses that this should be read by all coordinators, especially with regards to using someone else's Porsche as part of event. He also reports that the Waivers have not changed for this year. Coordinators need to make sure that the information about their events are accurate on the region website. In addition, information regarding additional insured's must be passed along to Keith well in advance of the event so that Insurance certificates can be issued in time. Keith will try to send out the certificates at least 2 weeks prior to the event.

Concours Report: John Diwik reports that the February Chili Tasting and Concours School will be held at Napleton Porsche in Westmont. James Jacisin reports that a Zone sponsored Concours Judging School will be held at The Porsche Exchange in Highland Park. This will be advertised on a national basis in hopes of attracting

participants from across the country. The Exchange has agreed to defray costs.

Rallye Report: Cindy Jacisin reports that Steve has Rallyemasters for all but one event. She also reports that he is in the process of looking for a location for the Rallye School and that Jack Stephensen has once again agreed to teach it. It is also noted that the Windy City BMW Club will list our Rallyes on their website after successful participation in some of last year's events. The board was made aware of Region member Bill McClean volunteering to lead a tour in WI. Unfortunately the dates he provided would not work for 2012 so it was suggested that it be postponed until 2013.

Social Activities Report: Cindy Jacisin reported that there will be a Mix'n Mingle at CoopersHawk Winery in Arlington Heights, IL on January 20. Carl and Carol are also looking at another Social Event in February and exploring a "Cars and Coffee" morning event. Cindy also stated on their behalf they would need a deposit for Flag Creek Golf Course which would be the site of the 2012 Halloween Party. Other events that they were considering are a Car Show with the Kane County Cougars, and a tour of the WeatherTech Factory in Bolingbrook. Ed Barnicle noted that we will be returning to White Pines Golf Course for the annual golf outing. Cindy Jacisin then congratulated Sharon Ptak on a great dinner dance. Sharon then reported that they had gone over budget by a slight amount due to adding of a projector stand and screen at the last moment for the awards presentation. Cindy then announced that Keith Clark and Chuck LaMantia will be coordinating the 2012 Dinner Dance and that they had already booked Butterfield Country Club in Oak Brook as the venue. They have contracted for 180 people.

Membership Report: Nicky Sangdahl reports that in November we had 1706 Primary Members, 1310 Affiliate Members, 14 New members, 3 transfers, 1 transfer outs, 70 renewals and 26 non-renewals. She also stated that

we will be offering two \$100.00 dollar raffles prizes at the Membership Meeting to be used for events for the year. Nicky also reported the Forest Awards mistakenly ordered the logo's used on our name badges as pins and has agreed to sell them to us for 50 cents apiece. Nicky will be purchasing them to use as hand outs at the membership meeting.

Safety Report: Todd Conforti reports that he is looking at possible changes needed for this year. He advises that the Tech Sheet needs to be updated for this year.

Technical Report: Kori Kwak reports that the Fall Tech session was a great success. It was held at Fischer Motors on November 6th. Fischer Motors served authentic German Food and Beer to all 115 people who attended. Kori reports that she was able to raise \$500.00 for the Charity at this event and thanked all who donated. Pete Faehnrich reports that National is allowing Karting Helmets to be used at the Parade Autocross. A short discussion follows and the Board states that Chicago Region will not adopt this practice. Kori Kwak reports that she was contacted by Midwest Eurosport as they would like to change that to only a one day Swap Meet for Chicago Region Members to be held on Saturday, May 12. The Board agreed to this change.

Charity Report: Cindy Jacisin reports that she has two Charities that will be presenting at the next two board meetings.

Buddy Program: Brian Beierwaltes -no report

Chicago Scene Report: Susan Shire -no report

Sponsorship / Dealer Liaison Report: Jim Ptak reports that he has met with Kori Kwak and all the information for Sponsorship has been transferred to him. He states that he will start meeting with potential Sponsorship Participants over the next several weeks.

Historian's Report: Jim Jacisin reports that he has sent articles to Susan for publication.

Webmaster's Report: Carl Walsted reports we have a website and that he is in the process of updating officers, directors and coordinators on the site.

Zone 13 Report: None

Old Business: None

New Business: Ed Barnicle reports that his Grandson has been chosen as a Make-a-Wish recipient. The Make-A-Wish Foundation was a PCA-Chicago Region Charity several years ago.

Next Meeting: February 10th, 2012 at the Park Ridge VFW Hall.

Porsche Club of America Chicago Region Board Meeting Minutes February 10, 2012

Voting Members Present: Cindy Jacisin, Toby Duckett, Stanley Sangdahl, Jack Stephensen,, Ed Barnicle, Keith Clark, and Chuck LaMantia

Coordinators Present: James Jacisin, Cheryl Lehman Collier, Chris Inglot, Nicki Sangdahl, Michael Grove, Carl Armand, Carol Armand, Peter Hackenson, Jim Ptak, and Carl Walstead

Members and Guests Present: Patrick Yanahan, Bob Danko, Terri Gorman, Kurt Konrath, and Debbie Crisk

President's Report: A quorum being present, Cindy Jacisin called the meeting to order at 8:06 p.m. at the Park Ridge VFW Hall, Park Ridge, IL.

Secretary's Report: Keith Clark motions to approve the minutes of the last meeting as submitted by Jack Stephensen. Motion approved

Charity Presentations: Cindy Jacisin welcomes the representatives of three Charities that have come to make presentations to the board. The first to present was "for autistic kids", the second organization was "Almost Home Kids" and the third was "Equestrian Connection" All

three organizations made moving presentations and were thanked by Cindy Jacisin for attending. Two more presentations are scheduled for the March board meeting. Cindy reminds the board that they will convene at the end of the March Regular Board meeting to choose the charity for 2012.

Treasurer's Report: Stanley Sangdahl distributed an accounting for the year to date. Stanley reports that BlackHawk has been paid for all events being held there. Stanley also reports that deposits have been sent to Gingerman Raceway, Autobahn Country Club and Road America. Stanley reports he has been in contact with Bowen and Bowen to prepare the tax filings and to do the annual review of the books. Motion Approved

President's Report: Cindy Jacisin reports that we received a Plaque of Recognition from National in honor of our 55th year. They are passed around the room for everyone to see. Cindy also reports she has 55th Anniversary Decals to pass out at events. Cindy then thanks Bill McClain for his donation to this year's charity. She then thanks Nick Christopher for the donation of 200 Hot Wheels cars to Toys-for-Tots. A discussion on the Scene regarding the need for a schedule of when the Scene is going to be published. A discussion of the printing of the directory follows as to whether or not it can be moved to the web. Cindy then reports that the Region received a Thank You card from Bob Gummow and Heartland Hospice for the donation made in the memory of Virginia Gummow.

Vice President's Report: Toby Duckett takes the opportunity to thank Cindy and all the Coordinators for the job they did at the General Member's Meeting. It is also reported that due primarily to the efforts of Stanley and Nicky, we raised monies for our Charity. Toby recommends that next year we bring our own PA system.

Autocross Report: Cheryl Lehman Collier reports that she has contracts coming in for the Autocross sites. She reports that we have confirmed contracts with Sugar River Go-Cart Track and Toyota Park. She is still in

the process of confirming events at Balmoral Park. Cheryl says she will need deposit checks to secure the sites. Motion Approved

Autocross School: Cindy Jacisin reports that Ed Leed informed her that the costs for the lunches at the Autocross School have increased this year. Ed has proposed charging raising fees for the Autocross School.

Timing & Scoring Report: Pete Bukantis - no report

Road America Report: Keith Clark reports he has been in discussion with Road America over the fees for this year. They have presented two options to us for Memorial Day. Keith and Chuck then present a detailed breakdown of the rates from the last two years. He then suggests a program to cover the additional costs due to the increase in the Track Rental. The Board discusses these changes and then approves the rate structure as presented. Pricing will be on ClubRegistration.com by March 1.

Blackhawk Farms Report: Pete Hackenson reports that BlackHawk Farms raised the rates for this year. This is the first time in 3 years that the rates have been increased. Pete then reports that Blackhawk decreased the rate for Oktoberfest Weekend. Pete recommends that the rate for the single day Blackhawk Events be increased. The Board agrees to the proposed increase. Pete reports that all contracts have been signed and paid.

GingerMan Report: Scott Lynn - no report

Autobahn Report: Chris Inglot proposes tincreased rates for this year. The Board agrees to the proposed increases. Chris also reports that he has booked a block of rooms at the Fairfield Inn.

Chief Driving Instructor' Report: John Ruther - no report

Insurance Report: Keith Clark reports we have insurance for the upcoming events.

Concours Report: Michael Grove reports that all plans are in place for Concours School and Chili Tasting event to be held at Naplelton Porsche in Westmont. Michael reports that in addition to the traditional program he is adding an Introduction to Concours. Michael reports that the Zone Concours Judging School is being advertised in Panorama and is posted on the National Website. This event is going to be held at The Porsche Exchange in Highland Park. In addition funding of the event is being supported by National.

Rallye Report: Cindy Jacisin reports that Steve has Rallyemasters for all the events. Cindy relates that Steve does not see a need for an increase in the rates for rallyes for this year. Cindy concludes saying that trophies have been decided upon for this year and that the Rallye School will be at Perfect Power.

Social Activities Report: Carl and Carol Armand report that the following events are scheduled on the calendar for the year:

Friday, March 16, Mix 'N Mingle, Cooper's Hawk, Arlington Heights
Saturday, April 21, Car Show / Base Ball Game, Kane County Cougars Stadium
Saturday, May 19, Coffee & Cars, LaBriola, Oak Brook
Sunday, June 10, Ravinia, Doctor John with "Iron & Wine"
Saturday, August 18, White Pines Golf Outing
Sat/Sun, October, 13/14 Driving Tour to New Glarus, WI
Saturday, October 27, Halloween at Flagg Creek Golf Club
Saturday, December 8, Dinner Dance at Butterfield Country Club
Carl and Carol then report the following two events are unscheduled but planned:
Tour Weather Tech factory run by Cindy Jacisin
Billiards Get Together run by Pat Yanahan
Carl and Carol then report that weather should not be an issue for the Kane County Cougars Baseball game scheduled for April 21. They report that our seating area is covered and they we will have access to a Sky Box. They

also report that the parking area is fully paved. Porsches will be parked in their own lot with general parking nearby.

Membership Report: Nicky Sangdahl reports that the Membership for December was 1,712 Primary Members and 1,312 Family/Affiliate Members. She reports that this is one more primary member than a year ago and three less Family/Affiliate members making total membership 3,024 as of December 2011.

Safety Report: Todd Conforti - no report

Technical Report: Peter Faehnrich reports that they have two people registered for the Spring Tech Session that is being held at Northstar Motorsports.

Charity Report: Cindy Jacisin reports that she has two more that will be presenting at the next board meeting.

Buddy Program: Cindy Jacisin reports that a handful of people signed up at the

Membership Meeting and 5-6 signed up with Nicki Sangdahl. Brian will pair them up as we get closer to the start of the season.

Chicago Scene Report: Susan Shire - no report

Sponsorship / Dealer Liaison Report: Jim Ptak reports that he met with Faris Nijim of The Porsche Exchange and Faris has agreed to continue Sponsorship for this coming year. The Board thanks The Exchange for their continued support. Jim reports that he has sent letters to all of last years sponsors.

Historian's Report: Jim Jacisin - no report

Webmaster's Report: Carl Walsted reports we have a website.

Zone 13 Report: Cindy Jacisin reports that she will be attending the Zone 13 President's Meeting in March.

Old Business: None

New Business: None

Next Meeting: March 2nd, 2012 at the Park Ridge VFW Hall.

Tirebibs
PATENT PENDING TM

View Video

Floor Protection Mats
www.Tirebibs.com
331-472-0711

Messy Floors No More!

PERFECT POWER

GIAC Tuning

Audi, BMW, Mercedes Benz, Mini, Porsche service & tuning



Potent **GIAC** flashes available for your Audi, BMW, MB, Mini Cooper and, of course, Porsche. The **GIAC** software produces huge torque and power gains on the turbo charged models, especially with the correct hardware.

Call us regarding chassis set up and data acquisition systems for your track cars. We can do all of your normal maintenance as well. Visit our website.

Perfect Power. 1009 Commerce Court. Buffalo Grove, IL 60089. Phone: 847.465.8837. Email: perfectpower@sbcglobal.net. Website: www.perfectpowerinc.com

ADVERTISEMENT - Not PCA Chicago Region Driving Events

BEYOND DRIVING

YOUR LIFE IS WAITING...
GET ON TRACK

AUTOBAHN COUNTRY CLUB - FULL TRACK
MAY 7, JUNE 18, JULY 23, AUGUST 20, OCTOBER 8

ROAD AMERICA
JUNE 4 & 5

OPTIONAL ADVANCED DRIVING SCHOOL WITH PROFESSIONAL
INSTRUCTION BY THE 2011 GRAND AM GS CHAMPIONS
ANDREW DAVIS & LEH KEEN OF BRUMOS RACING

AFFORDABLE MEMBERSHIP OPTIONS

SINGLE TRACK DAYS AVAILABLE



630.205.0055

lapsincorporated.com

ENTER OUR FREE TRACK DAY RAFFLE

14 Porsche Acronyms Explained

Source: *PorschePurist.com* *Porsche Factoids* [Source: *Porsche Technology Glossary*]

When it comes to acronyms Porsche is probably the only car company in the world that could compete with the US Army when it comes to their use. We receive emails on an almost daily basis asking us for information/help on one Porsche acronym/system or another. Instead of continuing to answer each email as a one-off we decided to create a post (with the help of Porsche's technology micro-site) that outlines the most common acronyms. Where possible we gave a link for more information and in most cases the link will have a video further explaining Porsche's technology. We will eventually convert this post to a permanent page, under Porsche resources, so it always available (and update it as necessary). For now, if we missed something or you think we should add an acronym, just let us know by commenting below.

DFI: Direct Fuel Injection

Porsche's Direct Fuel Injection helps to reduce fuel consumption CO2 emissions without compromising performance. At the heart of the system lies an injector which sits directly on the cylinder head injecting fuel directly into each combustion chamber with the help of a high pressure pump at a pressure of up to 120 bar. This disperses the air/fuel mixture more precisely, increasing the mixing of air and fuel. Because direct injection reduces cylinder temperature, more air than normal can be compressed into the combustion chambers. This increases the energy density of the mixture and hence leads to fuel saving. It is possible to control the required fuel volume exactly via the duration and pressure of injection.

LSDL: Limited Slip Differential Locking

A mechanically locking rear differential is standard in the 911 all-wheel drive variants and is available as an option for all other 911, Cayman and Boxster models in conjunction with 18 and 19-inch wheels. It further enhances traction at the driven rear axle on uneven roads and when accelerating out of tight bends. This is accomplished by the damping of load-change reactions during fast cornering. If you're buying a Porsche and you think you might want to play with on a track, the LSDL option is something you should seriously consider.

MOST: Media Orientated Systems Transport bus

The data exchanged between the various audio and communications systems is done via the Media Orientated Systems Transport (MOST®) bus. This powerful digital technology uses high-speed fibre optics to ensure absolute consistency during data transfer. An essential prerequisite for advanced audio quality, it links the CD autochanger, BOSE® Surround Sound System amplifiers and PCM telephone module (all optional). The result is a significant improvement in sound reproduction.

PASM: Porsche Active Suspension Management

PASM is an electronic active damping system. It offers

continuous adjustment of the damping force on each wheel, based on current road conditions and driving style. At the press of a button, the driver can choose between two modes. While 'Normal' mode provides a blend of performance and comfort, the 'Sport' setup mode has a much firmer range of settings. The system responds to changing road conditions and/or driving style by continuously varying the individual damping forces within the parameters defined for the selected setup mode ('Normal' or 'Sport'). Pitch and roll are reduced, whilst contact of each wheel with the road is optimized.

PCM: Porsche Communication Management

As the central control unit for audio, navigation and communications PCM is available as standard equipment on all Turbo models and optionally available for all others. PCM can be further configured with everything from a TV tuner (in some markets) to Navigation and Bluetooth. If you like your Porsche full of gadgets, this one should not be missed.

PCCB: Porsche Ceramic Composite Brakes

PCCB technology provides unparalleled fade resistance and consistently high friction levels by utilizing specially treated carbon fiber ceramic discs and composite pads in conjunction with six-piston calipers at front and a pair of four piston units at the rear. Other key benefits include the remarkable durability of the pads and discs, and over a 50% weight decrease over conventional metal equivalents. If you're looking to reverse the course of the Earth's rotation when you slam on the brakes, then PCCB is for you. Be warned though, there has been lots of discussion about the good, bad and the ugly when it comes to the PCCB option. They are expensive to maintain and even more so to replace. The general consensus we've heard is that if you track the car often and can't afford the replacement costs, go with the standard/steel brakes. If, however, money isn't an issue, you don't want any brake dust or just have to have those eye poppin' yellow calipers, then by all means, go for it!

PDK: Porsche Doppelkupplung

Porsche's newest transmission is essentially two half-gearboxes in one and thus requires two clutches – designed as a double wet clutch transmission. This double clutch provides an alternating, non positive connection between the two half-gearboxes and the engine by means of two separate input shafts (input shaft 1 is nested inside the hollowed-out input shaft 2). In English, this means the next gear (up or down) is always ready to go and no matter how good you think you can shift a manual, the PDK transmission is faster! More importantly, PDK will make you a better driver on the track. While some argue that it takes some of the tactile feel from track driving, we're of the opinion that if it makes for faster times then... why not?

PDCC: Porsche Dynamic Chassis Control

Available on the Panamera and Cayenne models PDCC is

an active anti-roll system that anticipates and significantly reduces lateral body movement during cornering maneuvers. In addition, it minimizes the lateral instability of the vehicle on uneven ground. The effect is achieved with the aid of active anti-roll bars on the front and rear axles which respond to the current steering angle and lateral acceleration by producing a stabilizing force that precisely negates the roll of the body.

POSIP: Porsche Side Impact Protection System

Standard on all current models, POSIP provides an additional two air-bags on each side (one for the body and one for the head) located in different positions depending on the Porsche model. POSIP includes additional safety features unique to each Porsche model based on its configuration.

PSM: Porsche Stability Management

PSM is an automatic control system that stabilizes the vehicle at the limits of dynamic driving performance. Sensors continuously monitor driving direction, speed, yaw velocity and lateral acceleration. Using this information, PSM computes the actual direction of motion. If this direction deviates from the desired course, PSM initiates braking interventions targeted at individual wheels in order to stabilize the vehicle.

PTV: Porsche Torque Vectoring

PTV is a system that actively enhances vehicle dynamics and stability. As a function of steering angle and steering speed, accelerator pedal position, yaw rate and vehicle speed, PTV is able to improve steering response and steering

precision significantly by specific braking of the right or left rear wheel. In other words, if the 911 Turbo is too much car for you to handle, PTV can help to keep you from stuffing your new 911 if you take a turn way too fast for your driving ability. 😊

UAI: Universal Audio Interface

With this optional feature, the storage compartment in the centre console in combination with the optional PCM will contain up to three connections: one for your iPod®, one for a USB stick/MP3 player and one as an AUX interface for any compatible audio source of your choice. The iPod® or USB stick can be controlled conveniently and safely using the PCM.

VarioCam and VarioCam Plus

Okay, we know it's not an acronym, but so many people asked we thought we would include it. Variocam is Porsche's variable valve-timing system. According to Porsche it continually adjusts valve timing for increased power and torque to provide smooth running at all speeds, better fuel economy and lower emissions.

VTG: Variable Turbine Geometry

Available on 911 Turbo, 911 GT2 and the Cayenne Diesel with Variable Turbine Geometry it is possible to achieve higher turbine speeds, and thus higher boost pressure, at lower engine rpm. Cylinder charging is significantly improved, with a corresponding increase in both power and torque. Maximum torque is reached at lower rpm and is retained across a wider rev range.



signpalace inc.

SINCE 1969

847.640.1335
mrsign@signpalace.com
ELK GROVE VILLAGE, IL 60007

- CUSTOM STRIPE KITS
- UNIQUE DIGITAL GRAPHICS
- TEMP / PERMANENT NUMBERS



MEMBER DISCOUNT!

PORSCHE GRAPHICS SPECIALISTS

signpalace.com

FISCHER

MOTORSports

GERMAN SERVICE EXPERTISE

PORSCHE • MERCEDES • BMW • VW • AUDI



Discover Why so many Customers Bring Their German Cars to Us.

Try the GERMAN Repair Service You Don't Know About.

At Fischer Motors we're GERMAN car specialists...building our reputation with our customers since 1975. No one else in the northwest suburbs has over 30 years of experience with GERMAN cars. No one.

If you're particular about your German car, sooner or later you'll come to us. And you'll discover why so many people bring their German cars to Fischer Motors.

Complete repair & maintenance • Transmission • Brakes • Suspension

For more information and to make an appointment call:

(847) 304-8822

22221 N. Hillview Dr. • Lake Barrington, IL 60010
847-304-8822 • Weekdays 8am - 5pm Saturdays 8am - 1pm
Pickup and delivery service available. Loaner vehicles.

Chicago Region Buddy Program

Brian Beierwaltes, Buddy Program Coordinator

We can all remember the time we attended our first PCA event. I know for me I was a little nervous as I didn't know anyone and had no idea what I was doing or where I was going. Lucky for me I paddocked next to someone who was willing to give me a hand throughout the day. It was because of that extended hand that I have now been participating in club events for 7 years and many of my good friends were met through the club

As a result of our version of the first time experience, John Ruther and I recognized that we needed to come up with a way to help new members or exiting members more easily attend their first event. After all, you only get one first impression and we wanted to be sure we could leave a good impression. In 2011, we launched a new program called the Member Buddy Program.

The idea of the program is to partner first time attendees with an experienced member to help them experience their first event and meet people in our region. The experienced

member connects with the new attendee prior to their first event to talk about their goals as well as help them prepare. Then they meet the new attendee at their first event to help them through the ropes as well as introduce them to other members in the club.

The program caught on fairly well last year as we had nearly 45 people sign up. This year we are continuing the program so if you are new to the club or an existing member thinking of trying a new type of event please feel free to take advantage of the program.

To do so, please provide reach out to me and let me know your contact info below as well as your area(s) of interest.

My contact info is xupkid2@hotmail.com or 847.404.7289.

I look forward to seeing you at the events in 2012.

Barrington Coach Haus *Automobile Collision and Restoration Perfection* *Since 1984*

BCH specializes in Porsche, Mercedes Benz, and BMW. We take pride in our workmanship from dings & dents to complete restoration and detailing. All work is guaranteed. We will come to you with our Mobile Estimating Unit.

BCH is your one stop body shop!

21 N 966 Pepper Road

Located approximately 1 mile east of Fischer Motors

Barrington, Illinois

847.381.8221

Mon - Fri: 8:00 - 5:00

Sat: By Appointment

Contact: Chuck Harley - Owner

Porsche Napleton Racing (PNR) has the experience and personnel to get you on the right track today.



Ron Barnaba – Team Principal

Also Napleton Porsche of Westmont's General Manager, Barnaba is a career Porsche professional who brings decades of experience not only at the dealership, but also in the race shop and on the track.



Matt Hartsfeld – Race Shop Manager

From ground-up builds to full track preparation and advance support, Hartsfeld is a Senior Porsche Master Registered Technician who keeps PNR's day-to-day operations moving.



Isaac Fritsche – Team Manager/Crew Chief

Fritsche is a Weissach-trained Porsche specialist with winning experience in legendary GRAND-AM and ALMS races as well as the 24 Hours of Nurburgring, where he was part of Manthey Racing's overall distance record in 2009 and the Porsche Factory GT3 Hybrid race launch in 2010.



Jack Baldwin – Lead Driving Instructor/Coach

A road racing legend and three-time IMSA and SCCA Pro Racing champion, including the 1992 Trans-Am title, Baldwin is available for everything from trackside advice at club events on up to coaching and co-driving at national series events.



Marc Gomora – Lead Race Technician

A factory-trained Porsche Gold Meister Technician, Gomora's passion for Porsches has fueled his interest in racing as a top technician, driver and instructor for nearly 20 years.



Steve Jenkins – Competition Development and Driving Instructor

A winning driver and race team owner, Jenkins is another PNR team member with extensive experience with Porsches and behind the wheel which makes him the ideal coach or co-driver at any level.



Ben Lacy – Race Technician



Joe Buonsante – Research/Design and Product Specialist



Kerry Terlep – Dealer Liaison



Jenni Tuton – Business Development Manager



Porsche Napleton Racing

201 E. Ogden Avenue Westmont, IL 60559 • www.napletonmotorsports.com • (630) 725-0911 or Toll Free (866) 344-9169

How Did The Fun Start?

Toby Duckett, Vice President

I was asked by our President Cindy to write an article on how and why I got involved with the Chicago Region PCA. The story really begins due to my first sports car and my interest in the Road America race track during the 1960's era Can-Am cars and later years CART series racing. Since I have an English heritage, my first sports car was a 1973 Triumph TR-6 that Bonnie, my wonderful wife and I purchased direct from the factory in England in 1973. This was the car that we drove throughout England, France, Switzerland, Austria, Germany and Belgium. After driving 3500 miles including 2 laps of the Nurburgring full track, we shipped the car back to Chicago. After 7 years, I sold the TR-6 to a friend; however, several years later I tracked down the same car in Michigan to rebuild it and own it again.

When the TR-6 rebuilt was complete, I went up for my first visit to a Chicago Region TRAC event invited by Todd Conforti. I have known Todd through my work since he built control panels then and still does for equipment I sell. This was back in 1993 when Todd and Pete Hackenson worked RADE and TRAC. By 1995, I sold the Triumph to buy my first 1982 911SC Targa, worked TRAC Tech, received my first Chicago Region Tech shirt, and began being hooked forever to the Chicago Region PCA.

While the 1982 Targa was a great fun car, it really was not a great track car. One day in 1999 while it was pouring rain, my left leg was wet again from the leak in the Targa top, I was driving by a dealer with a 1993 RS America which needless to say is a much, much better track car. Within 3 hours, I was a very happy person, but only after I let my dear wife see the car and tell her that this Porsche would be my last fun car. Bonnie does not remember that I also told her that the next one would be very serious. My DE track life began.

I worked with Todd and Pete on several TRAC weekends through DE and CR tech work. I got to know all the great people in DE tech and DE drivers. ete and Keith Clark got me to take over for doing DE tech for several years, 2001 to 2007 from my memory. My best Region decision to date was to get Peter Faehnrich involved to take over DE Tech when I was getting more active on the Region Board. During

these years, I was doing DE, Autocross, and even one or two Concour events. Bonnie and I started doing rallyes and even been rallyemasters over the past four years. This has been very enjoyable for both Bonnie and I to share time in the car and all the rallye teams. Getting active in Rallye work was due mainly to Susan Shire, Steve Rashbaum, and Jack Stephensen.

From 2008 to 2010, I was honored to be a National Club Race Scrutineer mainly due to Susan Shire. his was an adventure and experience I will never forget. I was able to go to first time Club Races in Las Vegas and New Jersey along with experienced Club Races in Texas. Besides getting to know National CR staff, it was fun to see how other clubs ran a club race. I wish I could have continued except for my very busy work schedule at that time.

I have been on the Chicago Region Board as a director from 2005 to 2011 and now your Vice President. I told the nominating committee I would run if nominated, and serve if elected. I consider this a wonderful honor. I trust I can serve you all as well as several of our prior VP and Presidents.

The point of this article is to recommend that you get involved in some way through the wonderful people in our club. Enjoy your car at one of the many different events in Autocross, Concour, Driver Education, Rallye, or Social during the year. You are all welcome to our Board meetings as well. We are a volunteer group of Porsche car owners that are always ready to welcome you.

The WHY I got active in the club was to drive a Porsche as fast as I possibly could on race tracks including Road America and to be honest, take a break from my daytime work. Now, it is because of the great people, the cars, and the joy of driving a Porsche.

The HOW I got active in the club is due to Todd Conforti introducing me to the Chicago Region Porsche Club at TRAC even before I owned a Porsche. There are many people that helped me in the early years including Pete Hackenson, Keith Clark, and Dan Gallagher to name just a few.



2012 Chicago Region Charity

What Is An Autocross?

Cheryl Lehman Collier, Autocross Coordinator

An Autocross is a low speed competition event requiring precision and skill as you negotiate a tight course marked by rubber pylon cones. From tight, low speed slalom sections to short bursts up to 50 or 60 MPH, the action is fast and furious. Quick reflexes and finesse are more important than huge horsepower. An Autocross abuses your nerves more than your Porsche, so it will not destroy your budget or your car. However, please be aware that Autocrossing may be habit forming and lead to doing things with your Porsche that it was designed to do.

We offer a ninety-minute class discussing the fundamentals of high performance driving. Following the classroom session, you will receive personal instruction at the skid pad, braking, slalom and ninety degree turn exercises. Finally, we will coach you as you drive a complete Autocross course at your own speed. Times will not be taken since this is an educational, not a competitive event.

Our events this season are:

April 29 Autocross School @ Maywood Park, Melrose Park, IL

Chaired by Ed Leed and Cheryl Lehman Collier our Autocross Driver School is a fun, must attend event for new members and anyone who just bought his or her first Porsche! This driver education event is an excellent opportunity for all 16 to 18 year olds in PCA's Junior Participant Program to gain some safe hands-on experience behind the wheel of their parent's Porsche as well. For Junior Participant Program info log on to http://www.pca.org/portals/insurance/FAQ_JuniorParticipationProgram2010.pdf

This event will run Rain or Shine. The skid pad is much more fun when it is wet!

- 8:00 a.m. Technical Inspection Opens in the West Parking Lot (Park your care here)
- 8:00 a.m. Registration Opens in Maywood Park building (Walk from the parking lot)
- 9:15 a.m. Classroom Session (Tech Inspection of entrants' cars will continue during class)
- 11:15 a.m. On Track Driver Instruction at the skid pad, slalom, turn and braking areas
- 12:15 p.m. Lunch (Box lunch provided)
- 1:00 p.m. On Track Driver Instruction at skid pad, slalom, turn and braking areas
- 3:00 p.m. Autocross Course driving with on-track instruction

Pre-registration by April 23 is required: Lunch is included in the registration fee and must be ordered in advance.

Our deadline for ordering box lunches is Monday, April 23rd. Entrants registering after April 23rd or on the day of the Autocross School at the event site will not have lunch provided.

May 20 Balmoral Park, Crete, IL

Balmoral Park was a new venue for the Chicago region last season and was given a huge thumbs up by all in attendance so we are once again embracing this gigantic parking lot which provided one of the best events we had all last season. Another stellar course will be set up that will be long, fast, challenging, and above all, fun! Come out and join us for another wonderful time.

Feel free to bring your lunch or, if you'd prefer, there is a grill that makes an assortment of hot food inside the horse track. After the completion of the event and the awarding of trophies to the victors feel free to join many of us who will be congregating at the Peotone Bierstube (306 N Harlem Ave., Peotone, IL 60468) for what we like to call the "after glow". This involves food, beverages, rehashing good and bad runs, comparing notes and typically some good-natured trash talking. We ate there last year and the food and atmosphere were outstanding!

June 24 Tire Rack, South Bend, IN

July 22 Sugar River, Brodhead, WI

August 12 Toyota Park, Bridgeview, IL

September 9 Balmoral Park, Crete, IL

OPEN MON-FRI 7:00 - 5:30
SAT 7:00 - 1:00

R. A. Adams
ENTERPRISES, INC.

TRAILERS
HITCHES
TRUCK EQUIPMENT

Full Service/Electrical • Custom Paint/Graphics • Full Line of Accessories

(815) 385-2600
2600 W. RTE. 120, McHENRY, IL
(3/4 MILE EAST OF FOX RIVER)
www.raadams.com

OVER 500 TRAILERS IN STOCK • FINANCING & NATIONWIDE DELIVERY AVAILABLE
FAMILY OWNED & OPERATED FOR OVER 45 YEARS!

Why Do I Like Autocross?

Jim Ptak, Sponsorship / Dealer Liaison

First reason is: It's fun. It's competitive. I feel like I'm actually trying to accomplish something. I'm trying to improve. I'm trying to beat all those pesky Boxsters, Caymans and 911s (who says an old 944 Turbo can't be competitive in an autocross?) I get instant results and gratification – make a run, and a minute or two later, I get a printout telling me just how much I improved (or didn't), down to the nearest hundredth of a second.

I get to spend the day hustling my Porsche around, using it as it was meant to be used: accelerating, braking, and zipping around corners.

Yeah, autocrossers sometimes get flak from D.E. regulars and the club racers, claiming it's "cute" that we "race around in a parking lot." Well ... ok, that's true most of the time (hey sometimes we take over a go-kart track!) But take it from me – as someone who HAS been there, done that with the "real" (as they would call it) racing scene (2 wheels instead of 4, but no less real racing – with the bills and receipts to prove it!) it is NO less fun. And when you factor in the costs, you absolutely can NOT beat the bang-for-the-buck that you get with autocross. Personally, I put autocross halfway between D.E. and Club Racing, since you can approach it in one of two ways. You can tackle it like a learning experience (D.E.) and cruise around, have fun, and really experience what your car can do. Or you can tackle the competitive angle (like Club Racing), sizing up your competitors and trying to win, but with, in my opinion, a lot more pressure. I like the competition and the pressure. I have to learn the course quickly (they're different every time) AND figure out how to put down a fast lap before the day is done. On top of all that, I usually only get 10 or so attempts to do it so generally I have to make each run count. It really forces me to concentrate and think about what the car and I are both doing out there, and stay focused and under control.

There is also great camaraderie. First and foremost, everyone is out there for fun. And everybody wants to see everybody else having fun, so between runs there is lots of chit-chatting, questions, advice, and even some gentle ribbing and trash talking (but all in good fun!) Feel stuck or confused and there is no shortage of advice available and new ideas to try from fellow competitors.

But it's not just about competition. There are real skills involved. Useful skills. I've learned a TON about how my car feels at the limit (and way past it!), in a controlled, safe environment. I learned that, as much of an expert as I thought I was, I was actually nowhere near what my car could do. My car is also too old to have ABS, so I had to learn how to threshold brake – that is, brake hard enough to be right on the verge of locking up the tires. Helpful when it came time to panic stop on I-90 one morning last fall, and kept a minor bump (and bent front license plate) from turning into a total loss.

And who hasn't charged down an empty expressway on-ramp just a liiiiittle bit faster than you probably should have? Maybe the tires made a little noise, or the car even wiggled a little bit? Autocross helps with that. I learned what my car feels like BEFORE it lets go, so I stay out of trouble in the first place.

The 2nd time I ever autocrossed my 944 Turbo (I'd only owned the car for a month or two at that time), my wife and I were up at Miller Park in Milwaukee for a combined Chicago/Milwaukee/Madison region event. There was a particular section of the course that was a pretty fast, sweeping turn, one that had me right in the big meaty part of my car's power band in 2nd gear. I was trying my best to chase down Ken Winger in his early 944 N/A, and went in just a teeny bit too fast. Rear end of the car got loose, and around I went, in most spectacular fashion, with cones flying everywhere! (My wife even got it on video! I'll post a link to it on the PCA Chicago Facebook page so you can see it.) My lead-footed wife had a similar experience, when she got a demonstration of "turbo lag" and what happens when the boost comes up mid-turn at Tire Rack in 2010: she left the course backwards and found herself down in the grass in pretty short order! Now imagine if had this all been "learned" on the road? Chances are, we wouldn't have been laughing about it. But now I have that experience – I know what the car will do, what that feels like, and can stop well BEFORE I get to that point.

It's also safe. Those folks who volunteer to design the courses we run on take each person's safety with the utmost priority, and we don't want the risk of someone going home hurt, or worse... a damaged car! (Wait... did I get that backwards?) There's always enough room to get the car stopped safely, with the worst thing to hit being a couple rubber cones. I've hit a bunch, and my car has lived to tell the tale without a scratch.

So there ya go. My wife and I both love it and can't get enough. I hope maybe some of you will come give an autocross event a try this year. We've got some great new venues this year, and we held on to the best of the new venues from last year (with some BIG lots, which means some BIG and FAST courses.) Bring your spouses, too. Plenty of room for everyone, and you can share the same car too.

Welcome to Concours Competition

Michael Grove Concours Co-chair

So you joined the Porsche Club of America (PCA) and somewhere along the line you saw the word "CONCOURS." And you probably said to yourself, "Self, what the... is Concours?" And then you said, "Why do people do it?" Here are a few thoughts from a Concours contestant who has been involved in competition for the last 13 years.

If you appreciate the design and engineering that went into your Porsche and want to get close and personal to it, then nothing brings you closer than cleaning, polishing and buffing the components that make up your Porsche. During the process, your Porsche will be prepared to a higher level, even better in some cases than when it was built. Your efforts can lead to a situation where you are preserving and protecting to a level where your car will last many years and still appear to be a new car. Your efforts are rewarded with a Porsche that is free of corrosion and rust. A Porsche with leather that is supple, and free of cracks and fading. A Porsche with wheels that are clean, shiny and free of brake dust and road rash. A Porsche with a chassis and engine free of grease, oil, dirt and grime. And in the process you have learned about all the nooks and crannies that exist in your Porsche. I have spent many hours "praying" to the wheels of my Porsches but the results are impressive. People will come up to you and tell you how nice your car looks. Other drivers

will drive erratically just to get near your car and see how beautiful it is. Strangers will give you a "thumbs-up." Hot chicks will want you.... Or perhaps hot dudes will want you..... (You decide....) Or maybe you will just have the satisfaction of knowing that your Porsche looks great. So what is the history of this "Concours" thing? They were originally called a **Concours d'Elegance**.

- A Concours d'Elegance (from French meaning a competition of elegance, lit. "concourse of elegance", referring to the gathering of prestigious cars) dates back to 17th Century French aristocracy, who paraded horse-drawn carriages in the parks of Paris during summer weekends and holidays. Over time, carriages became horseless and the gatherings became a competition among automobile owners to be judged on the appearance of their automobiles.
- Traditionally vehicle judging at a Concours d'Elegance is much more demanding than that of a neighborhood or general automobile show. Trained judges examine the vehicle thoroughly and in its entirety.
- Concours Judging in the Chicago Region is based on the best preparation and maintenance of the Porsche, as the



2012 Concours Events



- Feb. 19 Concours School & Chili Tasting
Napleton Porsche, Westmont
 - April 22 Concours Judging School
The Exchange, Highland Park
 - May 6 Bolingbrook Concours (Concours 1)
Promenade Mall, Bolingbrook
 - June 17 Long Grove Concours (Concours 2)
 - July 21 Potter's Picnic and Concours (Concours 3)
Fischer's Estate, Grayslake
 - Aug. 5 Charity Car Show, ABT, Glenview
 - Aug. 26 Charity Car Show, Geneva Concours
Geneva, IL
 - Sep. 1 Elkhart Lake Concours (Concours 4)
Siebkens, Elkhart Lake, WI
 - Sep. 23 Burr Ridge Concours (Concours 5)
Burr Ridge Village Center
 - Oct. 13 Driving Tour and Rally weekend - Wisconsin
- Refer to www.pca-chicago.org for up to date club event details and registration information**



car was originally manufactured or properly modified due to a Porsche factory recall or modification. (Think cleanliness and condition.)

- Non-factory modification or aftermarket parts (such as wheels, seats, etc.) will be judged for best preparation and maintenance and will not be penalized. (Think cleanliness and condition.)
- Originality shall not be judged.
- All cars must possess a Porsche VIN number.
- We are judging against perfection, not comparing one Porsche to another.
- Concours competitions in the Chicago region are divided into **classes**.

Corral Class: display only, Cars are not judged – This is where you can park your clean Porsche and enjoy the day with other Chicago Region members.

Exhibition Class: exterior and interior are visually inspected. Judges do not touch the vehicle. (This a great place to start competing and learn...). Enter your Porsche in this class, ask questions, and learn from others.

Show Class: exterior, interior and compartments are judged – The next step in the progression of Concours preparation. When you are ready to make the commitment to preparing your car.

Touring Class: exterior, interior, compartments and engine are judged – Another step up in the progression and for those members willing to commit to cleaning that engine compartment with all it's hard to reach places.

Full Concours Class: exterior, interior, compartments, engine and undercarriage are judged. The class for serious, die-hard competitors. When you are ready to spend hours looking at the underside of your Porsche....

- Concours competition is an evolving process.
- A Concours winning car does not occur overnight, even if you start with a new car.
- Each event is a learning experience.
- Your efforts will be rewarded.
- Time invested = Results
- Your fellow PCA members are an excellent resource.

**Have Fun!
Meet new friends!
Ask Questions!**



LN ENGINEERING

Aircooled Precision Performance



Nickies™ The Original & Genuine Solid Aluminum CNC Billet NSC-Plated Cylinders



66% Stronger & Twice the Cooling - 80-105mm Lifetime Warranty on Plating • 356, 911 & 914 PRICES STARTING AT \$4099 6CYL \$2899 4 CYL INC. FORGED JE PISTONS ALL MODELS 1948-1998

Blown engine? Want more power? We have your 'D' chunk or slipped sleeve Cylinder repair solution!



Nickies™ for 986/987 & 996/997 models \$4199 INC. FSR ULTRA-LIGHT JE PISTONS STOCK OR BIG BORE SIZES UP TO 4.0 LITERS UPGRADE TO TRIPLE CERAMIC IMS BEARING \$895 9A1 MY09+ DFI BIG-BORE TO 4.0+ ALSO AVAILABLE



R&R Pro Connecting Rods
Manufactured exclusively for LN Engineering CRYO-TREATED BILLET 4340 CHROMOLY MOST SIZES IN-STOCK THRU 997 MODEL 6 CYL \$1699 | 100% MADE IN THE USA



MY97-12 M96/M97/9A1 UPGRADES
Improve your engine's reliability and longevity

- Low-Temp Thermostat \$99+
- Spin-On Filter Adapter \$135
- Magnetic Drain Plug \$23
- Oil Change Bundles Available
- Billet Racing Oil Filter \$250
- .5 & 2 qt Deep Sump \$283+
- HPDE Accusump \$1359
- "X51" Dual Oil Scavenge Pump Kits \$1699+
- Power Steering Cooler Kit \$150
- External Oil Cooler Adapter (Heat Exchanger Delete) \$270
- Billet Tensioner Paddle \$272
- Chromoly Oil Pump Drive \$20
- ARP Rod Bolts \$243
- ARP Carrier Bolts \$177



IMS Guardian
Engine Failure Detection System
The first line of defense against IMS Bearing failure.

IMS Retrofit™
MY97-05 M96 MODELS CERAMIC BEARING STRONGER DESIGN SINGLE & DUAL ROW \$619 IMS PRO TOOLKIT \$189







815-472-2939
www.LNEngineering.com

dealer inquiries welcome | prices subject to change | please mention this ad when calling





TRUST THE PORSCHE PROS



When it comes to Porsche service, you can count on the professionals at Loeber Motors

The largest Porsche sales and service facility in the Midwest, the Loeber Motors Porsche service and parts facility encompasses over 10,000 square feet of space, including twelve service bays. Complete with the latest state-of-the-art diagnostic equipment and the top certified Porsche technicians in the field, the Loeber Motors Porsche Service Center offers convenient indoor drive-in lanes each staffed by an accommodating team of experienced service consultants.

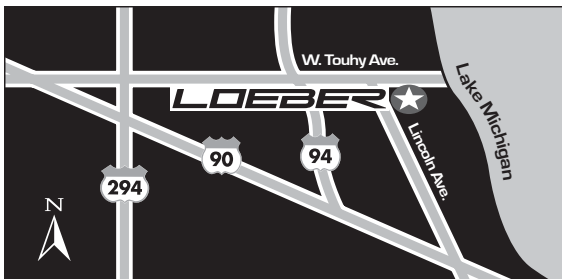

A Special Invitation

We'd appreciate the opportunity to provide you with exceptional service on your Porsche. For a limited time only, we're offering you **\$25 OFF** your next Porsche engine oil and filter change. It is our way of saying "welcome!" We feature:

- A comfortable customer lounge featuring premium coffee and fresh baked goods.
- A complimentary car wash with every service visit.
- An Early Bird Drop-Off Box is available 24 hours, 7 days a week for your convenience.
- Convenient online service appointment scheduling is available now at www.loebermotors.com.

We're Thirty Minutes From Anywhere!

Loeber Motors Porsche is centrally located in convenient Lincolnwood, just minutes from the city and minutes from the North Shore. With easy access from the Edens, Kennedy and Northwest Tollway, Loeber Motors is literally thirty minutes from anywhere!

SERVICE DEPT. HOURS: Monday-Friday 6:30am-8pm • Saturday 8am - 5pm | Call (888) 595-8296 to schedule your service appointment today!

\$25.00 OFF

your next Porsche engine oil and filter change

Valid only at Loeber Motors in Lincolnwood. Must present coupon at time of service. Not valid with any other offer. Offer expires 12/31/12.

Sports Cars Non Turbo	Regularly: \$150	With Coupon: \$125
ALL Turbo Cars & Older 993 911s	\$225	\$200
For Cayenne Models	\$165-215	\$140-190
Panamera	\$195	\$170

Regularly:	With Coupon:
\$150	\$125
\$225	\$200
\$165-215	\$140-190
\$195	\$170



LOEBER MOTORS

The Largest Porsche Sales and Service Facility in the Midwest

Search our extensive new and certified pre-owned selection of Porsche vehicles online at www.loebermotors.com
Loeber Motors 7101 N. Lincoln Avenue Lincolnwood, IL (888) 595-8296

GO CHICAGO. GO LOEBER.

Top 10 Reasons to Rallye

Steve Rashbaum, Rallye Coordinator

10. Enjoy exploring new places
9. Don't feel the need to use maps or GPS
8. Need to take or give directions
7. Love puzzles
6. Wish to improve communication skills
5. Desire to take some things literally
4. Crave new challenges that are not work or family related
3. Want to spend time in your Porsche with others.
2. Have a need to drive your Porsche on the open road
1. Need to spend time with like-minded crazed people

The Chicago Region hosts Time-Speed-Distance rallyes. Though many of us would like to think that we should run World Rallye Championship type rallyes, we have decided on the more sane TSD rallye.

A TSD rallye is one where you match your navigational and driving skills against a Rallye Master who will provide directions and speeds over specified distances. The Rallye Master computes the perfect time and contestants are scored by their measured time against the perfect time.

Sounds simple, doesn't it. The directions are not like following a nav system but rather a set of literal instructions to follow to remain on course. The challenge for the rallye team is to interpret the instructions correctly and keep to the designated speed. Rallyes are run on public roads (we will not ask you to exceed the speed limit) so you will have to contend with not only following directions but stop lights, stop signs and traffic.

To succeed, the rallye team must develop good communication skills and teamwork. Rallyes will test your concentration for about three hours. You will have to ignore beautiful scenery and Porsche roads.

From those of us who have been rallying for years, you will hear a lot of jokes about divorces (no murders yet), slammed car doors, partners not speaking to one another and make up speed. Some are true, some are exaggerated, but all are part of the fun.

Rallying is a load of fun. It is another way to spend time in your Porsche on fun roads with a partner. It is a chance to share tall tales with fellow rallyists and enjoy the raucous camaraderie of fellow rallyists before and after a rallye.

Experience the fun yourself. Come to the Rallye School for a sneak preview.

* Want to join in on the fun after the School? There is a short Rallye School before each Rallye. It won't be as comprehensive as the Rallye School on April 15th but it should be enough to get you 'on the road and to the last checkpoint'.

** Want to rallye, but don't have a partner? Contact Steve Rashbaum steve.rashbaum@comcast.net and we'll see if we can find you one.

*** Want to just join us for the fun? There is always a need for CheckPoint workers --- free 'on-the-spot training is always available.

**** Want to drive the route but not compete? Come on out and we'll find a way to 'get you out there'.

2012 Chicago Region Rallye Schedule

April 15	Rallye School, Perfect Power, Buffalo Grove
June 3	Rallye 1
July 1	Rallye 2
August 19	Rallye 3
September 16	Rallye 4
October 14	Rallye 5 in WI (combined with Driving Tour and Social)

VAN A. LARSON, P.C.
Attorney and Counselor

www.vanlarsonlaw.com vlarsonpc@netzero.com

630-879-9090
630-879-9102 (f)



233 W. Wilson St.
P.O. Box 185
Batavia, IL. 60510

“ On The Hill in Downtown Batavia “

CENTURY 21 1ST CLASS HOMES
724 East Schaumburg Road, Schaumburg, IL 60194
Phone: (847)584-6604



Peter S. Sygieda

Cell: (312)404-9965
peter@petersygieda.com

Each office is independently owned and operated.

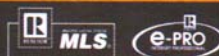

CGC

Clear Guard for Cars Inc.

The "Ultimate" in Paint Chip Protection



Preserve your vehicles beauty.

Eliminate paint chips & scuffs.

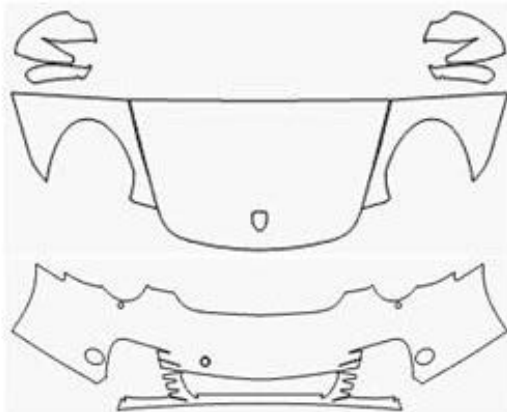

Computer designed
& vehicle specific
for each application.

Custom applications
also available.

We are also a mobile
service.

3M Certified installers

www.clearguardforcars.com 847 571-0381
Hoffman Estates IL

Membership News

Nicki Sangdahl, Membership Coordinators

The Chicago Region welcomes our newest Members!

Carol Arnold
Brad Arnold
2007 C4S

Julius Macjules
2003 911

Thomas Palmer
1983 944

Moma Vidakovic
2012 Carrera 4S

Kevin Barton
Lisa Barton
2000 Boxster

John Gaydos
1986 944 T

Scott Sattovia
Stacy Sattovia
2010 Cayman S

Paul Wagner
Wesley Wagner
1988 924 S

Mathew Behning
2002 Carrera

Meg Gorecki
2002 996

Samme Thompson
1999 911

Haihao Wu
2006 Boxster

Paul Bonaguro
2005 Carrera

Tim Hamann
1992 911

Richard Browne
1978 911 Targa

Steve Hansen
1999 996

Jeff Brozek
2005 997 C2S

Bob Hertel
1997 993

Buddy Burzik
1987 911

Paul Hydzik
Caprice Hydzik
2008 Cayman

Bruce Chandler
2006 Cayman S

Teddie Kossuf
1987 928 S4

John Cifonelli
David Cifonelli
1987 911

Gary Kukla
Chris Kukla
1991 911

Al Dalessandro
2007 997

Steve Levy
Lisa Levy
2001 911

Alan Devereaux
Gale Devereaux
2002 996

Terrence Lydon
2004 911

Alex Dias
1987 944 T

Tom McBreen
2008 4S

Louis Ertel
Teresa Ertel
2006 911

John Neyer
Heather Neyer
2007 Cayman S

Brad Fridell
2003 911

Tom O'Brien
2002 911 TT

**PORSCHE EVENT
OF THE YEAR!**
amidst the stunning beauty of the Great Basin

**THE 2012
PORSCHE PARADE**

**SALT LAKE CITY, UTAH
JULY 8 - 14, 2012**

PCA's Premier Event Of The Year!

- Autocross • Concours • Rally • Driving Tours
- Tech Sessions • Social Events • and more!

Salt Lake City -
Mountains - Scenic Wonder - Crossroads of the West

**Registration
closes
June 22,
2012!**

Learn more and register at parade2012.pca.org

DESI VINCZEN
BOB VINCZEN

Body Works of Barrington

SPECIALIZING IN MERCEDES, PORSCHE AND B.M.W
ALL IMPORTED SAPORTS CARS

126 N COOK STREET
BARRINGTON, ILLINOIS 60010

PH 847.381.9144
FAX 847.381.9163

THE MIDWEST'S LARGEST PORSCHE SPECIALTY SHOP

EUROSPORT *Racing*



STREET, AUTOCROSS, RACE CAR PREP • ENGINE DEVELOPMENT • PERFORMANCE MODIFICATION • ALIGNMENT • DYNO TUNING • MOTEC FUEL INJECTION & TUNING



For more than 20 years, Eurosport has offered the Midwest and the Chicagoland area, the finest in Porsche service and repair for every Porsche made. From the Carrera GT "supercar" to a '55 356, we have everything needed to keep your Porsche in top-notch condition. From Scheduled Maintenance to complete engine re-builds, the pros at Eurosport can make it happen!

EUROSPORT BENSENVILLE

104 W. Irving Park Rd.
Bensenville, IL 60106
630-595-5577 tel
630-595-8096 fax
weatheredb@aol.com

EUROSPORT *Racing* JOLIET

Autobahn Country Club
3671 South Patterson Rd
Joliet, IL 60436
815-727-5577 tel
weathered1@aol.com

www.midwesteurosport.com



PCA Chicago Region 2012 AutoX Tech Sheet

NAME: _____ CLASS: _____ MEN'S LADIES

YEAR/MAKE/MODEL: _____ UTQG _____ CAR COLOR: _____ CAR #: _____

!!! TO BE INSPECTED BY ENTRANT PRIOR TO EVENT !!!

Pass Fail

- | | | |
|-----|-----|--|
| ___ | ___ | 1. HELMET - SNELL SA or M 2005 or later required. Face shield required for cars without windshields.
Snell SA or M sticker must be attached inside |
| ___ | ___ | 2. APPAREL - Full-length pants, long sleeved shirts, socks and full shoes are recommended.
Bare feet, sandals, and open toed shoes are not permitted. Recommended are fire resistant drivers' suits, driving gloves and shoes (cotton, wool, silk) or PCA Club Racing approved fire resistant fabrics. |
| ___ | ___ | 3. SEAT BELTS/HARNESSES - Must be present and adequate. Showroom Stock Classes must use factory belts.
Where installation is other than factory design, the belt mounting must be securely anchored, metal-to-metal, with large diameter washers on both sides of floor mounting holes. Non-factory shoulder harnesses may be used in an open vehicle only if the automobile is equipped with a rollbar or cage. |
| ___ | ___ | 4. FIRE EXTINGUISHER - Recommended but not required. Securely anchored metal-to-metal in reach of driver.
BC or ABC rated and fully charged. AFFF or Halon recommended. |
| ___ | ___ | 5. ROLL BARS/CAGES - Recommended in open automobiles driving in Improved classes.
Roll Bars are required in open vehicles driving in Modified classes, cages are optional. Must be equipped with adequate padding. |
| ___ | ___ | 6. PEDALS - Free return and in good operating condition. Firm brake pedal. |
| ___ | ___ | 7. LOOSE OBJECTS - Remove all loose items from trunk and interior, including glove compartment, door pockets, console, etc. Spare secured properly (spare adds to the structure of certain Porsches). |
| ___ | ___ | 8. AIR BAG EQUIPPED CARS - No obstructions in front of Air Bag (s). |
| ___ | ___ | 9. WINDSHIELDS/WINDOWS - No major cracks. Bolt-on windshields may be removed.
Driver and Passenger windows must be fully up or fully down.
Contestants must use a face shield if driving a vehicle without a windshield in any class. |
| ___ | ___ | 10. REMOVEABLE ROOF PANELS/CONVERTIBLE TOPS/SUNROOFS - Any automobile may run with their top down.
Removable roof panels must be removed or fully secured. Tilt-up style panels/sunroofs must be removed or fully closed. Sliding Sunroofs may be open. |
| ___ | ___ | 11. GAS CAP - Gasket intact and cap tightened. |
| ___ | ___ | 12. RUST - No rust or damage to suspension or chassis parts that affect the integrity of the chassis or brakes. |
| ___ | ___ | 13. STEERING and SUSPENSION - No excessive looseness in steering or suspension.
Axle and shock bolt tight. Ball joints in good condition. Tie rods secure. Axle boots and oil seals in good condition.
Check half-shaft bolts and shock bolts, 914's check fuel pump and lines. |
| ___ | ___ | 14. CAMBER - (356 automobiles) No positive camber on any car. |
| ___ | ___ | 15. WHEEL BEARINGS - Correct adjustment, check for play and proper lubrication, no damaged or burnt bearings. |
| ___ | ___ | 16. BRAKES - Must be tested for pedal "fade" while vehicle is stationary.
Brake linings/pads should be 4mm thick for disc brakes, 3mm thick for drum brakes. |
| ___ | ___ | 17. WHEELS - No cracks. No bends. All lug nuts must be torqued to manufacturer's specifications, minimum one diameter of engagement. Snap-on wheel covers and trim must be removed from steel wheels. |
| ___ | ___ | 18. TIRES - Must be free of visible sidewall cracks. Clearance between tires and any potential rubbing point must fall into compliance of chosen car classification. |
| ___ | ___ | 18. BRAKE FLUID - Level up, must show in reservoir. |
| ___ | ___ | 20. BATTERY (IES) - Securely fastened and in good condition. No acid leaks or corrosion. Check fuel lines under battery trays on 914's. The Positive (+) Terminal on All batteries must be covered by cap or tape. |
| ___ | ___ | 21. EXHAUST - Must be in safe condition, no leaks, securely mounted. |
| ___ | ___ | 22. SEAT BACKS - Must be suitably secured if not equipped with locking devices. |
| ___ | ___ | 23. LEAKS - No exhaust leaks or fluid leaks of any kind. - Oil, gas, brake, or coolant. |
| ___ | ___ | 24. THROTTLE RETURN - Freely operating and with good springs on cars so equipped. |
| ___ | ___ | 25. BRAKE LIGHTS - All bulbs on both sides and center brake light (if so equipped) must be functional. |
| ___ | ___ | 26. HOOD AND DECK LIDS -Must fasten securely. |

All cars must adhere to the rules as defined by the previous year's PCA Parade Competition Rules!

In consideration of my participation in this event, I have checked the above items and certify that they meet or exceed the requirements. I agree to indemnify and hold harmless the organizers of the event, or their agents, with respect to responsibility for the condition and preparation of my car, or any subsequent mechanical failures or resulting damage to my car, its occupants and the venue facilities as a result of any such failures. I acknowledge that at all times; I remain solely responsible for the safety and roadworthiness of my car.

I hereby certify that I have no physical or mental problems, which could jeopardize any others or me if I participate in this event.

ALL OF THE ITEMS ON THIS TECH SHEET HAVE BEEN TESTED AND SERVICED AS DESCRIBED. THE TECH INSPECTOR'S SIGNATURE BELOW DOES NOT IMPLY COMPLIANCE WITH THE ABOVE AND IS ONLY AS WITNESS TO THE DRIVER'S SIGNATURE, WHICH WARRANTS COMPLIANCE.

DRIVER'S SIGNATURE: _____ DATE: _____

WITNESS TO DRIVER'S SIGNATURE (Inspector): _____ SERVICE STAMP _____ DATE: _____

Revised 1-23-12

EXERCISE REGULARLY!



AUTOBAHNCC.COM

QUESTIONS CALL RON DABISCH 815-823-8570

RONDABISCH@AUTOBAHNCC.COM

PCA Chicago Region 2012 DE Tech Sheet

NAME: _____ DRIVER CLASS: _____ RUN GROUP: _____

MODEL/YEAR: _____ CAR COLOR: _____ ENG. DISP.: _____ CAR #: _____

Driver Classes: Green (prior C) is least experienced, progressing to Yellow, White & Black the most experienced.

Pass Fail **!!! TO BE INSPECTED BY ENTRANT PRIOR TO EVENT !!!**

Inside

Harness Requirements!

1. **HELMET - SNELL SA 2005 or later required for all Track Events** including Autobahn, Blackhawk, GingerMan and Road America. Full face required for all open cars. **(Snell SA sticker must be attached inside)**
- 1a. **HELMET - SNELL SA or M 2005 or later required for all Autocross events**
Full face required for all open cars. **(Snell SA or M sticker must be attached inside).**
2. **APPAREL** - Full-length pants, long sleeved cotton shirts, cotton socks and full coverage shoes are mandatory. Highly recommended are drivers' suits, driving gloves and shoes all made of Nomex or similar fire-resistant materials. Arm restraints required for All Open Cars.
3. **SEAT BELTS - Novice, Green, Yellow & Autocross**, may run with stock seats and belts.
White Group requires a 5 or 6-point harness with proper race seat, rollover protection highly recommended.
Black Group requires a 5 or 6-point harness with proper race seat **AND** rollover protection (see item 5).
All securely anchored, Metal-to-metal, with large diameter washers on both sides of floor mounting holes.
Harness and Seats must be equipped the "same" for Driver and Passenger side (Instructor).
4. **FIRE EXTINGUISHER** - Recommended but not required. Securely anchored metal-to-metal in reach of driver. BC or ABC rated and fully charged. AFFF or Halon recommended.
5. **ROLL PROTECTION (DE)** – Roll Bar, Cage or Extender using "broomstick rule" Required for Black Class. The same Roll Protection is **highly recommended** for other Classes. Arm restraints required for all open cars.
All Cabs in all classes (except Boxsters & 996 and later Porsche) must have Roll bar or better.
6. **PEDALS** - Free return and in good operating condition. Firm brake pedal.
7. **LOOSE OBJECTS** - Remove all loose items from trunk and interior, including glove compartment, door pockets, console, mats, etc. Spare secured properly (spare adds to the structure of certain Porsches).
8. **AIR BAG EQUIPPED CARS** – No Obstructions in front of Air Bag (s).
9. **WINDSHIELD** - No major cracks and functional wipers with good blades.
10. **MIRRORS** - At least one side (two highly recommended) and one securely mounted rear view mirror.
11. **GAS CAP** - Gasket intact and cap tightened.
12. **RUST** - No rust or damage to suspension or chassis parts that affect the integrity of the chassis or brakes.
13. **FRONT SUSPENSION** - No excessive looseness in steering or suspension. Lower trailing arm to radius tight; Axle and shock bolt tight. Ball joints in good condition. Tie rods secure. Axle boots and oil seals in good condition.
Warning: 944/968 MUST Check Ball Joint & Control Arms for cracks and binding caused by excessive lowering, larger sway bars and track usage.
14. **REAR SUSPENSION** - No excessive looseness. Check half shaft bolts and shock bolts. 914's check fuel pump and lines. No positive camber on any car.
15. **WHEEL BEARINGS** - Correct adjustment, check for play and proper lubrication, no damaged or burnt bearings.
16. **BRAKES** - Sufficient brake linings or pads. No rubbing, cuts or abrasions in brake lines. Check rotor condition. Brake pad thickness must be checked periodically for 2mm minimum thickness throughout the high-speed events. Make sure you start with ample brake pad material and/or bring an extra set of pads. It is recommended you start with fresh Competition pads properly bedded in.
17. **WHEELS** - No cracks. No bends. All lug nuts must have 94 - 96 lbs. torque. Valve stem must have airtight cap. Hubcaps and Center Caps must be removed for DE. Steel lug nuts highly recommended for DE.
18. **TIRES** - In Good condition. No cracks or bulges. ZR or better required (HR for Autocross only). Minimum tread depth of 3/32" on contact patch area (race tires or shaved performance tires must have as least 1/16" tread wear marker depth and No Cord Showing). Seek an experienced driver with like car/tires for hot/cold tire pressure.
18. **BRAKE FLUID** - Level up, must show in reservoir. **All cars must have their brake systems flushed with DOT 4 specification or better brake fluid 90 days or less preceding the high-speed event. If another high-speed event is run less than 90 days prior to this event, then the fluid must be flushed AGAIN before running.**
20. **BATTERY (IES)** - Securely fastened and in good condition. No acid leaks or corrosion. Check fuel lines under battery trays on 914's. The Positive (+) Terminal on All batteries must be covered by cap or tape.
21. **ENGINE** - Check for odd sounds and satisfactory exhaust (**103dB limit at all our DE tracks**)
22. **DRIVE BELTS** - Tight and in good condition.
23. **LEAKS** - No exhaust leaks or leaks of any fluid - oil, gas, brake, or coolant.
24. **THROTTLE RETURN** - Freely operating and good springs. Check both throttle return springs on CIS cars.
25. **BRAKE LIGHTS** – All bulbs on both sides and center brake light (if so equipped) must be functional.

Outside

Engine

103 dB Limits!

In consideration of my participation in this event, I have checked the above items and certify that they meet or exceed the requirements. I agree to indemnify and hold harmless the organizers of the event, or their agents, with respect to responsibility for the condition and preparation of my car, or any subsequent mechanical failures or resulting damage to my car, its occupants and the venue facilities as a result of any such failures. I acknowledge that at all times; I remain solely responsible for the safety and roadworthiness of my car.

I hereby certify that I have no physical or mental problems, which could jeopardize any others or me if I participate in this event.

ALL OF THE ITEMS ON THIS TECH SHEET HAVE BEEN TESTED AND SERVICED AS DESCRIBED. THE TECH INSPECTOR'S SIGNATURE BELOW DOES NOT IMPLY COMPLIANCE WITH THE ABOVE AND IS ONLY AS WITNESS TO THE DRIVER'S SIGNATURE, WHICH WARRANTS COMPLIANCE.

DRIVER'S SIGNATURE: _____ DATE: _____

WITNESS TO DRIVER'S SIGNATURE (Inspector): _____ SERVICE STAMP _____ DATE: _____

Revised Jan 29, 2012

The Mart

PCA Members may place ads of a non-commercial nature at no charge in The Mart. Ads will run for two issues only. The non-member, non-refundable fee for this service is \$20.00 for two issues. The check, which must be received before the ad is run, should be made payable to PCA Chicago Region and sent to the address shown below.

Ad material must be received by the 5th of the month for publication in the next issue and is subject to editing. Ads and photos may be submitted by e-mail.

Ad limit is 75 words or less. All photos submitted must be in digital format, may be tiff or jpeg but must not exceed 1 MG. No photos will be scanned by the editor.

The Mart/Chicago Scene
c/o Susan Shire
1897 Mission Hills Lane
Northbrook, IL 60062

Phone: 847.272.7764
Fax: 847.272.7785
e-mail: ChiScene@aol.com

For Sale - PORSCHES

1973 914/ 6-GT project car; all OEM parts; total body restoration/perfect steel flares/doors/lids/ rockers/ bumpers; new interior complete; too many OEM interior/exterior trim/mechanical parts to list; like New '94 Carrera C4 3.6 eng/1.8K mo; all new '86 915 trans/syncros; Quaife w/limited slip/lub system/Vellios 916 built by Jerry Woods Enterprises. new brake/calipers/rotors; all OEM parts; \$41,900 in/looking to sell everything \$22,000. Joel : 847.593.9880 (MA)



1987 944 Turbo Coupe Guards Red/Black leather seats/Recaro Driver's seat; 6 pt harness/Brey Krause harness bar; orig owner/all maintenance records; Fikse forged aluminum wheels; Bilstein struts; Brey-Krause harness bar; Chipped, boost enhancer maintained by Fischer Motors. Driver Ed. Ready. \$10,900 Chuck 773.209.9801 clmontagna2@comcast.net (MA)



1987 944 Turbo Diamond Blue/Burgundy trim; 79K mi; 1/2 cage/TRG adj. swaybars/Bilstein adj, shocks/Sparco speed seat (driver only)/harness both seat; stage 2 chips; 3" stainless muffler & pipes; Panasonic CD radio/four alpine speakers; 18"rims/like new Hoosier A6 competition tires; new Dunlop Direzzo DZ 101 tires on stock rims; obsessively maint. by Eurosport /all maint. records. \$8500. Jerry 630.533.1581 destinsuns@sbcglobal.net (MA)



1991 911 Carrera Cabrio Carrera White/Navy leather interior; Navy top; 72K mi; all orig; tiptronic; pwr seats/locks/windows/cruise; CarFax/maintenance records available; no track/tobacco/dings; Factory air (blows cold); ABS brakes w/new OEM rotors/pads (2010); clear bra; indoor cover; always garaged/stored winters; Great buy, \$19,500 Chuck 847.502.0872 Maddier1@yahoo.com (MA)

1994 968 Cabrio Amazon Green/Tan Leather; 80K mi; 6 spd; 17" Porsche Sport Whls w/ Pilot Sport (stock 16" wheels w/ new 4 season tires incl); Euro Front Signals (stock incl); Wind Baffle; 2 covers; . Antilock Brakes; AC; pwr steering/locks, cruise control; e-mail for pics. \$15,500. Hank hankestrada@gmail.com 773.480.4265 (MA)

1997 C-2 Guards Red/Black interior; Still smells new inside; 50,6K mi; 9 in/out-Custom mats & cover; maintained by Fabson Engineering. \$35,000. Don Emigholz 309.853.7974 (MA)



1999 Boxster Yellow/black 58Kmi; 5 spd man trans; orig owner; heated seats/traction & cruise controls; non-smoker/races; all recs; always garaged/stored winters; incl cover/Porsche battery maint; \$14,000. Lynette Poirier, 708.434.5389 lepoirier@gmail.com (JF)



2007 GT3 RS Black/Orange 7.7K mi; almost every factory opt: exc working cond/ looks fantastic inside/out; >\$25K in upgrades (inc race seats/Formula 43 wheels/M&M BROMBACHER Race Exhaust System) & more; orig Porsche Ceramic Composite Brakes barely used/ steel rotors; orig sticker price \$151,330; Eng Dyno'd 5/24/2011, 431 HP, 309 ft/lb torque. \$110,000. Steve Creech; 630.705.9482 (JF)

For Sale - OTHER

1998 Formula Mazda, ready to go \$17,500; **1994 Frazer Lemans Sport Racer**, Toyota twin cam, streetable right hand drive, made in new Zealand, \$31,000, Lots of fun! Has logbook; **1968 Corvette Vintage Race**, nut and bolt restoration \$42,000; 50% discount at GingerMan Fastguy Club with purchase. Dan 269.207.0913 (JF)

For Sale - TIRES/PARTS/MISC

Winter Tire & Wheel package Two each Pirelli 235/40/R18 & 255/40/R18 winter tires w/Cayman wheels plus Weathertech floor mats \$200 Paul 312.259.8858 (JF)

2007 Boxster/Boxster S Accessories Winter Tire/Wheel Set - 18" Moda

MD1 5-spoke rims w/Michelin Pilot Alpine PA2 N1 Winter tires (F) 235/40-18R (R) 255/40-18R – <10k mi. inc TPMS sensors & 4 - TireRack Tire Tote Bags \$950; Porsche Black Nose Bra w/Mirror Covers for Boxster S \$50; Porsche Silver Car Cover w/Bag \$75; Tonneau Cover \$50 anthonyhegarty.com or 630.677.6256 (JF)

Parts 993 6-spd transmission/Model G50/20/total stock; shifts nicely;

currently in a 1998 993/can test drive the transmission before buying; upgrading to an RS transmission. \$3900. Ernie 630.615.0345 earossi@yahoo.it (JF)

Parts 1994 Carrera C4 3.6 engine like new/1.8K mi \$12,000. '86 915 trans/complete new rebuild by Jerry Woods Enterprises/syncros/bearings/Quaife w/limited slip/Vellios 916 shift/oil lub system \$5,000. Both for \$15,000.

Perfect combo for 914 / 6 project. Joel: 847.593.9880. (MA)

Wanted - PORSCHEs

1995 to 1998 Porsche Carrera Coupe. Looking for a clean, low mileage 993 that needs a new home. Please contact Denis Downs 708-361-1160, Denis.downs@att.net (JF)

C	O	T	L	Y	E	H	C	S	R	O	P	Z	P	B
S	R	E	T	S	D	E	E	P	S	A	Y	O	N	A
R	M	T	C	A	N	O	X	O	A	T	U	B	N	T
O	T	R	A	C	T	O	R	B	M	E	T	M	A	T
A	C	L	Y	R	Q	Y	O	R	E	L	R	R	M	B
D	N	U	M	G	E	X	S	U	R	O	O	J	R	M
S	C	B	A	U	S	R	J	T	I	I	P	E	A	F
T	L	W	N	T	S	M	R	D	C	R	S	E	K	P
E	U	E	E	O	P	M	L	A	A	B	N	T	T	Y
R	B	R	P	I	Y	W	M	E	C	A	N	N	H	E
M	S	T	E	R	D	V	W	N	U	C	E	Z	A	N
A	P	C	A	Y	E	N	N	E	O	I	R	O	V	O
N	O	K	A	G	R	A	T	U	H	C	S	R	Y	O
A	R	E	M	A	N	A	P	R	L	N	A	C	A	M
O	T	R	A	I	R	E	B	Y	S	S	N	A	R	T

Solution in the May - June issue of the Chicago Scene

- | | | |
|-----------|-----------|--------------|
| BABY | GMUND | RSAMERICA |
| BOXSTER | KARMANN | SPEEDSTER |
| CABRIOLET | MACAN | SPYDER |
| CARRERA | MOONEYPFM | TARGA |
| CAYENNE | PANAMERA | TRACTOR |
| CAYMAN | PORSCHE | TRANSSYBERIA |
| CLUBSPORT | RENNSPORT | TURBO |
| COUPE | ROADSTER | |

Aungahh!

It's Spring! It's late Winter! It's Chicago and the saying goes something like "if you don't like the weather, just wait a few minutes and it'll change!"

Well, whatever it is, there's lots to do and the Chicago Region Calendar is full. Take a look at it in this issue as well as on www.pca-chicago.org as there's got to be something that looks like fun. If you're new to the Club, take a chance and try out a couple of things. The Schools are the perfect opportunity to try things out in a low key environment with lots of help and encouragement available.

There's information about the Buddy Program, Autocross, Rallye, and Concours in this issue. Next issue we'll talk about the Social, Tech, Charity, and Track parts of our Club.

It was nice to hear from so many of you telling us how much

you like BACKROADS. Larry Petry shared his story with Jim Jacisin and ended up in a column! We'd love to hear your stories and see your pictures as well. Send them to me or to Jim at jamesjacisin@mac.com

A reminder that the details for our many events is on the webpage. Many of our events require pre-registration and that pre-registration information is available on www.pca-chicago.org. It's not too early to sign up for many of the track events make your hotel reservations while you're at it.

PCA Parade registration is also open and it is filling up.

Whatever strikes your fancy, get up, get the car out, wash it, and just get out there!

Finally, below please see a note from the Milwaukee Region regarding an event that they have on their schedule.

Aungahh (a-úun-gaaa), n.
[Skip Barber Racing School].

- 1 The sound of the motor of a car as the clutch is depressed, the brakes applied, and the throttle "blipped" to effect a heel and toe downshift.
- 2 Editor's column

The Milwaukee Masterpiece or Wisconsin's Answer to Pebble Beach - August 25 - 26, 2012

Every August there is a fabulous **Concours d'Elegance** and **car club show** on the shores of Lake Michigan at Veteran's Park. The Milwaukee Masterpiece is Wisconsin's answer to Pebble Beach and Meadowbrook coupled with the welcoming blue waters of a truly Great Lake. Some of the finest examples from around the world gather at this annual event. August of 2012 promises to continue the tradition that will be of particular interest to those of us who own or follow German cars. In addition to the traditional "club day" on Saturday (8/25) which is open to all marques to gather on the grounds, there is a special class for the feature day on Sunday (8/26). On Sunday there will be a class for Teutonic Touring and Track Cars. The class will be open to German touring and race cars which are 1973 or older. Eligible marques include Mercedes Benz, Porsche, Audi, BMW, VW, etc. How about a Ford Lincoln/Mercury Capri rally car? Sunday is a by invitation event with those that wish to display their car applying for acceptance. It is really painless. Just send a few digital pictures of the car and a paragraph or two with the background describing what makes the vehicle unique and special. Send the material to either Mike O'Krongly at mokrongly@aol.com or to Ron Pace at ronald.pace@kohler.com. Space is somewhat limited so get your submission in quickly.

See you in August.

The Chicago Scene (ISSN 10564195) (USPS 0006-381) is published bi monthly (six times a year) by the Porsche Club of America (PCA)-Chicago Region, printed at PressTech, 959 Lee Street, Des Plaines, IL 60016-6545. Periodic Rate Postage paid at Des Plaines, IL. USPS Subscription is provided to members of the PCA-Chicago Region. PCA dues are \$42.00 annually, of which \$12.00 is for the subscription.

Permission from the editor is required to reprint any material published herein and full credit must be given to the Chicago Scene and the author. PCA-Chicago Region is not responsible for any services or products advertised herein. Statements appearing in the Chicago Scene are those of author and do not constitute an opinion of the PCA-Chicago Region or its Board of Directors.

All copy and advertising material must be received by the 5th of the month for publication in the next month's issue

and will be published on a space available basis. The editor reserves the right to refuse and/or edit all materials submitted for publication.

Articles are preferred in Word format. All photos submitted must be in digital format. All digital photos should be taken at the maximum resolution the camera allows (minimum 300 dpi). Photo file format may be tiff or jpeg but must not exceed 2 MG.

Commercial Advertising Rates (for 2 issues)
Business card: \$55.00 One-quarter page: \$125.00
Half-page: \$185.00 Full page: \$315.00
Covers: not currently available

2012 Publication schedule: January-February, March-April, May-June, July-August, September-October, and November-December

Susan Shire
Editor
1897 Mission Hills Lane
Northbrook, IL 60062-5760
ChiScene@aol.com
Phone 847.272.7764
Fax 847.272.7785

Send address changes to:
Postmaster
Ed Soske—PressTech
959 Lee Street
Des Plaines, IL 60016-6545
Leedlast@sbcglobal.net

The service of a full prep race shop.
The technical support of a certified Porsche dealer.



Twice as nice.



In addition to selling the world's most prestigious sports cars, Napleton Porsche of Westmont also serves all of your Porsche aftermarket performance and racing needs. We have management and technicians that have been a part of professional winning race teams, as well as professional drivers on our full time staff to lead you in the right direction. At Napleton Porsche Motorsports, we also have the distinct advantage of being an Authorized Porsche Dealer. This allows us to take care of any issues that may arise while installing aftermarket parts by using our extensive resources in our Dealership Service Department. Whether you're looking to improve street performance, track performance, or go racing, we have the staff, the knowledge and the facilities to make sure you reach your goals.

**COMPLETE CUSTOM
BUILDS & SERVICES:**



**TRACK
MODIFICATIONS:**

- Suspension Systems
- Data Acquisition
- Horsepower Mods
- Race Wheels
- Race Tires

**HIGH PERFORMANCE
STREET
MODIFICATIONS:**

**SAFETY
EQUIPMENT:**

- Roll Cages & Hoops
- Seats
- Belts
- Fire Systems

- Wheels
- Brakes
- Intake & Exhausts
- Suspension Systems

**AT TRACK SUPPORT;
D.E. AND RACE**

- Complete Prep Services
- Track Specific Setups
- Competition Alignments
- Storage & Transportation
- Certified Race Technicians

**HIGH PERFORMANCE &
RACE DRIVER COACHING**

- Multiple, race winning Porsche drivers available for one-on-one coaching

**NEW AND
PRE-OWNED SALES:**

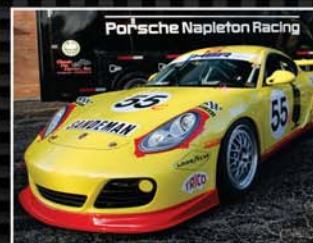

Cayman
INTERSERIES
ENDURANCE CUP ★★★
★★★ CHAMPIONSHIP



PROSPEED
RS683



Napleton Porsche
MOTORSPORTS

Chicago Scene

959 Lee Street

Des Plaines, IL 60016-6545

Dated Material

©2010 Porsche Cars North America, Inc. Porsche recommends seat belt usage and observance of all traffic laws at all times. Optional equipment shown is extra.



Legendary Porsche performance with four passengers. We're definitely defying the laws of something.

No one has the capacity to break the rules more than Porsche. And now, the new Panamera. The legendary sports car driving experience built for four. The staggering Porsche power is unmistakably present. As is the relentlessly precise handling. And with the addition of a second row of executively seated passengers, there's no end to the rules you can break. Porsche. There is no substitute.

The Panamera. Experience pure Porsche performance for four.

Joe Rizza Porsche

8130 West 159th Street
Orland Park, IL 60462
(708) 364-2400
porsche.rizzacars.com

Porsche recommends **Mobil 1**



PORSCHE