

CHICAGO SCENE



October 2003

Cuneo Concours • Gingerman

FREE SHIPPING HUGE INVENTORY TOP BRAND NAMES



**Customer Service. Competitive Pricing.
Free Ground Shipping. Tech Support.
We can help put you in front.**

Northstar Motorsports has earned a reputation as the premier source for motorsports safety equipment sales and knowledge. Our full-time staff of seasoned racing enthusiasts and professionals can help you select the best equipment for your needs.

With exceptional customer service, competitive pricing and free ground shipping on all orders, you will receive the most value on our large inventory of products from the best manufacturers in the world.

Northstar
MOTORSPORTS

WWW.NORTHSTARMOTORSPORTS.COM
Orders: 800.356.2080 | Tech: 847.304.5515 | Fax: 847.304.5615





CHICAGO SCENE



Four Decades of Porsche with the Cuneo mansion as a backdrop. Pictured are Bob Follmer 356B and Mike Haas' 993 Turbo.

IN EVERY ISSUE	Clark's Corner.....	3	Spare Parts.....	37
Advertisers Index	Address Change Form	35	The Mart.....	39
Calendar of Events	Board Meeting Minutes—AUGUST '03.....	33	Steve's Tech Corner	43
Behind the Scene.....	New Members Welcome	36	Directors & Coordinators	44

FEATURES

THE MIDSHIP REPORT – RETRACTIONS & CONTRACTIONS	5
EMAIL HUMOR.....	10
QUICK SHOTS FROM GINGERMAN.....	16
COMPETITION IS GOOD - AUTOCROSS III	21
CUNEO CONCOURS.....	22
2004 ELECTION BALLOT	31/32
TECH INSPECTION SHEET.....	36

EVENT ANNOUNCEMENTS

TRICK OR TREAT SOCIAL	6
AUTOCROSS RUN FOR FUN	8
OCTOBERFEST DE & DINNER 2003 . .	12
INDIANA ODYSSEY RALLYE	15
CONCOURS JUDGES SCHOOL	17
CAFE 36 SOCIAL	18
FALL TECH SESSION	20
DINNER DANCE	28/29

SUBMISSIONS TO THE EDITORS: Scott Adleman, Stan Reed & Cari Compton
Precision Research, Inc. 10600 W. Higgins Rd. Suite 100 Rosemont IL, 60018
E-mail: saa@prepres.com

Send address changes to: POSTMASTER: Bob Soske, PressTech
959 Lee Street DesPlaines, IL 60016-6545
E-mail: Leedlast@hotmail.com

Published articles and advertising are for general, informational purposes only. The opinions contained therein belong to the authors or sponsors solely. They are not meant to establish absolute technical and safety standards. Therefore, no authentication is implied by the editors or publishers.

SUBMISSION INFORMATION

Articles are preferred in MSWord but they can be contained in the body of an e-mail. Do not send articles in pdf format.
Digital photos: All digital photos should be taken at the maximum resolution the camera allows. At a minimum, pictures should be 300 dpi for use in the newsletter. File format can be either tiff or jpeg.
Commercial Advertising: For rates and technical information, contact the editor at 847-390-8666.

The Chicago Scene (ISSN 10564195) (USPS 0006-381) is the monthly publication of the Porsche Club of America (PCA) – Chicago Region, printed at PressTech, 959 Lee Street DesPlaines, IL 60016-6545. Periodical Rate Postage Paid at Des Plaines, IL USPS. Subscription is provided to members of the PCA – Chicago Region. PCA dues are \$42.00 annually, of which \$12.00 is for the subscription. Subscription rates for non-Chicago Region members is \$24.00 per year. Permission to reprint any material published herein is granted, provided full credit is given to Chicago Scene and the author. PCA – Chicago Region is not responsible for any services or products advertised herein. Statements appearing in the Chicago Scene are those of the author and do not constitute an opinion of the PCA – Chicago or its Board of Directors.

2003

CALENDAR OF EVENTS

Current Calendar of Events

OCTOBER, 2003

- Friday, October 3 Autocross Fun Under the Lights at Rockford Speedway
- Saturday, October 4 & Blackhawk Octoberfest Sunday, October 5 Drivers' ED
- Friday, October 10 Board Meeting at Park Ridge VFW
- Saturday, October 18 & Rallye V - Indiana Odyssey
- Sunday, October 19
- Sunday, October 26 Trick or Treat Social

NOVEMBER, 2003

- Saturday, November 1 Concours Judges' School
- Sunday, November 2 Cafe 36 Social
- Friday, November 7 Board Meeting at Park Ridge VFW
- Sunday, November 9 Fall Tech Session

DECEMBER, 2003

- Saturday, December 13 Holiday Dinner Dance and Awards Presentation



O c t o b e r • 2 0 0 3

<i>monday</i>	<i>tuesday</i>	<i>wednesday</i>	<i>thursday</i>	<i>friday</i>	<i>saturday</i>	<i>sunday</i>
		1	2	3	4	5
					Octoberfest @ Blackhawk DE & Pig Roast	
6	7	8	9	10	11	12
				Board Meeting at Park Ridge VFW		Autocross Fun Run New Location
13	14	15	16	17	18	19
					Rallye V Indiana Odyssey	
20	21	22	23	24	25	26
						Trick Or Treat Social
27	28	29	30	31		
Trick or Treat Social at the Weber Grill						

N o v e m b e r • 2 0 0 3

<i>monday</i>	<i>tuesday</i>	<i>wednesday</i>	<i>thursday</i>	<i>friday</i>	<i>saturday</i>	<i>sunday</i>
					1	2
					Concours Judges School	Cafe 36 Dinner Social
3	4	5	6	7	8	9
				Board Meeting at Park Ridge VFW		Fall Tech @ The Exchange
10	11	12	13	14	15	16
17	18	19	20	21	22	23
24	25	26	27	28	29	30

Advertisers Index

- 914 Limited 9
- Air Mortgage34
- Autobahn42
- R.A. Adams Enterprises9
- Bacino'sBC
- Body Werks of Barrington27
- Barrington Coach Haus14
- The Exchange4
- Fischer Motors9
- Kelly-Moss Motorsports41
- Lynch Porsche7
- Manny's9
- Midwest Eurosports19
- Midwest Performance Cars35
- Napleton PorscheIBC
- Northstar MotorsportsIFC
- O'hare Autobody30
- Porsche Cars NA11
- Property Consultants9
- Sound & Video Consultants27

Clark's Corner

by Keith Clark, President, ClarkFNFlying@aol.com

I find myself using the word Great a lot while writing my monthly articles but I really feel the word is perfect for describing our events. They are great! This years T.R.A.C. 2003 event at Road America was... GREAT. Pete Hackenson did his best work yet on putting this event together. Everyone had a great time while either driving, racing or showing their car at the Concours. This is a full weekend of activity for everyone.

I can't begin to thank everyone who volunteered his or her time to help. There were so many people involved, people from everywhere working together to make it all happen, without you this weekend would not have happened. Our registration was handled by Mary Anne Nowakowski who ran it like clock work while taking care of her husband Wes who had shoulder surgery days before the event. The Jacisin's put the Concours portion of the weekend together at Siebkens Saturday night. I think it's great to see the Concours and racecars all showing in one spot, to see the street and the race version of a car from the factory is really cool. I know we have the best tech crew in the world and they again proved it to us all. They are a great group of people Toby Duckett and Todd Conforti kept everything moving and everyone that helped them through out the weekend, thank you!

To try to stay fare, I never single anyone out that helps but I'm breaking my own rule. It seemed that every time I looked up or someone needed help I saw A.J Tiller first in line. If you know A.J and you enjoyed the weekend thank him,

he made a lot happen. Greg Turek and Nick Brenkus did a great job put together the parking assignments which is not a simple task seeing that everyone wants certain spots and they all want them at the same time. Chuck LaMantia did whatever need doing through out the weekend; he was everywhere working with everyone. Lee Lichtenstein has been working/running timing and scoring for our club race since it started eleven years ago. Lee has decided it's time to retire from his post as of this year, so when you see Lee thank him for many years of hard work and support. Thanks to everyone from the region and myself you all did a GREAT job.

I'm running out of room for this page but I wanted to Thanks Ed Barnicle for hosting the club's golf outing. It was a lot of fun and our group finished second. Not because of my talent I assure you it's the only time I ever won anything golf related. To the Irish team, to bad maybe next year. To the Irish team's, the Dutch won!

Please remember if you're interested in getting involve with publishing the scene please contacted me, we are still looking for as many people as we can get.

It's your club enjoy it.

Behind The Scene

by Scott Adleman, Editor in Chief

As I reflect on the Chicago Scene covering the last two years, I see several areas for improvement. Most of these improvement ideas involve scheduling. At times, we have tons of event photos but no story to accompany them. Other times we have a story, but no photos. And still other times, I receive two stories on the same event. Not wanting to leave the authors' efforts unappreciated, I run both stories, however, must be a better way.

At my request, the event coordinators have been making an effort to find people to write stories on each event. This has helped, but can potentially increase the likelihood for competing stories when someone gets an itch to write and sends an unsolicited article. Please don't begin to think that we don't want your story. The fact is we need all the writers we can get.

What would be nice is a website registration page where both photographers and writers could sign up for events or topic categories well in advance. This way everyone could know at a glance which events were covered and which were not.

In addition to knowing what is covered, we could also have four downloadable pages to inform volunteers of the project parameters.

First off, there could be a page containing material deadlines based on event dates and when they could expect to see the contributions published. For articles, the page could outline the story length which could vary by event type and duration as well as include the acceptable electronic file formats and transmittal methods. Another page would be for photographers. This one would outline ideal resolutions for digital photos, how to proceed if using regular film, and how to get reimbursed for film and developing expenses. In addition, it would also define acceptable transmittal methods. A final page would be for those interested in trying to make the cover. It is easier than it looks. The page would contain tips along with resolution requirements and transmittal information.

I'm not sure how hard this would be for Webmaster, Greg Gulik, to implement. But I would like hear your comments first. Let me know what your thinking. After all, it's our Club.



Porsche Cayenne

The Midwest's Largest Volume Porsche Dealer
Including The Largest Selection of New & Pre-Owned Vehicles.
The Exchange Porsche, where complete satisfaction has been
our commitment to our customers for 27 years!

R a i s e Y o u r E x p e c t a t i o n s
THE ✦ EXCHANGE
A Division of Semersky Enterprises Inc.



PORSCHE

2300 Skokie Valley Rd. • Highland Park • (847) 266-7000 • www.4porsche.com
Monday-Thursday 9a-8p Friday 9a-6p Saturday 9a-5p

THE MIDSHIP REPORT ©

Retractions and Contractions

by John Miller [Boxster_S@veryspeedy.net]

My luck ran out. Sort of. No sooner had I committed to print (last month's Chicago Scene) my apology to PCA-Chicago member Tony Janairo for having to miss yet another Autocross (as I was off to Sturgis, SD for the Bike Rallye), things went bad. There was some 11th hour bike sickness (mechanical) that eventually gave way to (12th hour?) personal sickness. So instead of spending a few

It's not BMW.

Porsche Cars offered and I accepted. The Cayenne Experience came to town in mid-August and I decided I should have a look and drive the beast. The photos (1-3) show what would appear to be an intriguing set of driving tests to put the Porsche SUV thru.....but it wasn't. I should explain that I've attended quite a few BMW events in the past (yeah, gasp and swoon),

tions: KEEP IT AT 3 MPH. YAWN. I push grocery carts faster. The road course portion was worse. The 'instructor' insulted the Boxster "yeah, it's nice enough...there are a lot of them out there..." and then got seriously annoyed with me when I fully tested the Turbo's antilock brakes. And that's when I induced a 4 wheel drift and started 'killing' course marker cones. Don't get me wrong, it's a capable



days of genuine insanity in the Badlands, I dragged my tired behind to the Autocross IV. And still, I managed to have a good time --- and I'm not ruling out Autocross V at Lake Geneva on Sept 14 ---but 2 weeks of stomach unhappiness is taking its toll.

so maybe I've been spoiled, but BMW really let me put their X5 thru the paces and get a feel for it. On road, off road, skidpad, even 15 minutes (actual seat time) of autocross—the BMW group understood how to bring car and driver together. At the Cayenne Experience, the off-road portion had clear instruc-

vehicle and the Turbo has the type of kick that Porsche will always be known for. I don't think I'll be asked back for the next edition.

Defector or Convert?

Or neither. Jim Jacisin, our (illustrious?) PCA-

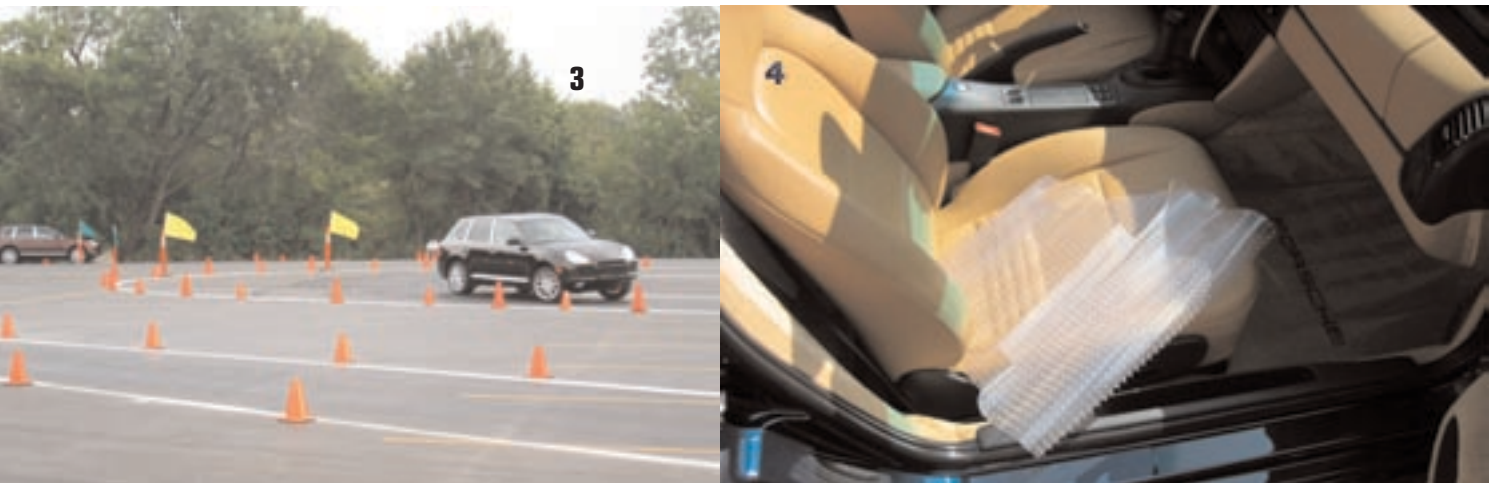

Continued from page 34

TRICK OR TREAT



BEARS VS LIONS FOOTBALL SOCIAL at the WEBER GRILL Lombard



You do not need to be a football (the Bears) nut to come out and enjoy the day, watch the game you would watch anyway, eat great food, yes pay for your drinks, but get the bonus of BBQ Tips at half time, talk about football, cars, etc.

Location: Weber Grill, Lombard, Illinois 630-953-8880 (NW corner of Rt 56 Butterfield Road & Meyers)

Date & Time: Sunday, October 26, 2003
Noon to ??? Come Anytime, but let us know

Menu: Barbbque Buffet including: Chicken Wings, Ribs, Pulled Pork, Plus More Cash bar

HIGHLIGHT: BBQ TIPS BY THE WEBER CHIEF AT HALF TIME

Cost: Only \$15.00 per person

Please send in the form or email Toby@mc2fyi.com with subject labled: Weber Grill, or I may not open your mail. We do need to confirm how many people will attend so we can prepare the food and reserve the proper number of seats.

Name: _____ No. People _____

When at Weber: Noon till ??? _____ 1st Half _____ 2 Half

Phone: _____ e mail address: _____

Payment Enclosed: \$15.00 x _____ people = \$_____

Mail to:
Toby Duckett,
23W272
Edgewood Court,
Glen Ellyn, Il.
60137



PORSCHE

Summer Sports Car Spectacular

NOW YOU SEE THEM

lynch offers chicago's #1 sports car inventory



NOW WE DON'T

lynch offers unprecedented summer clearance deals that guarantee immediate acceleration off our lot and into your driveway

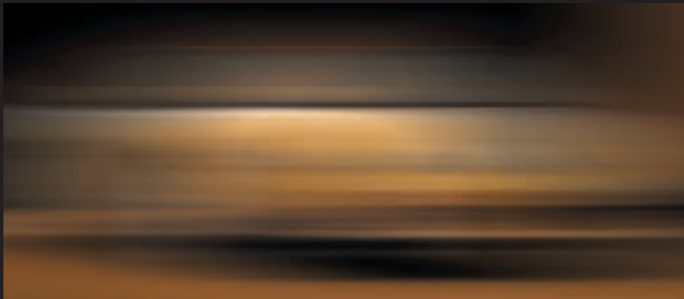

*SPEED IS A GIVEN.
UNPRECEDENTED SUMMER CLEARANCE DEALS
ON ALL BOXSTER'S & 911'S IS STANDARD*

LYNCH PORSCHE

5201 West Irving Park Road | Call John Landin: 630-781-6519
www.lynchporsche.com

Autocross Run for Fun Sunday, October 12 New Location!

Northeastern Illinois Public Training Academy

Come out for the last autocross event of the year. Put your Porsche or inferior sports car to test on the huge parking lot at NIPSTA. This facility is brand new and is the size of 3 football fields. There is over 160,000 square feet of pavement, with no poles or obstructions in the way. This event will not count as points and trophies will not be awarded. You are encouraged to bring new people who have never tried autocrossing to this event. In car instruction will be available. New members and those with 4 door sports sedans are encouraged to attend. Lunch and air are available near the track. Pre-Register by mail to create a speedier Event. Include permanent drivers number.

Directions: The NIPSTA facility is at 2300 Patriot Boulevard. NIPSTA is _ mile south of Willow Rd on the west side of Patriot. Or take Patriot north about 1 mile off of Lake Avenue. <http://www.nipsta.org/>-- Includes directions.

Time 9:00-10 AM	Registration and Technical Inspection Opens
10:15 AM	Tech is closed
10:15 AM	Drivers meeting
10:30 AM	First car off-Let the fun begin.
3:30 PM	Trophy presentation

First driver	\$25.00 member	\$25.00 non-member guest - member must be present
Second driver	\$10.00 Family Member	\$10.00 non-member guest - member must be present
	\$25.00 member sharing car with other member	

Directions: It is 8600 West North Ave in Maywood, between 1st Ave and 5th Ave. You can exit the Eisenhower Expressway at 1st Ave and head north to North Ave. Turn left on North Ave and Maywood Park is on the left. Enter from 5th Ave.

General Rules: Snell 1990 helmets are required. Short/Long pants and shirt. 18 years or older with valid drivers license. Member may bring one guest to event. Guest may drive members Porsche or a two-door sports car. Associate Member driving a non-Porsche is considered a guest. Maximum two drivers per car. Trophy with first car you drive. Member must be present with guest.

Please register by mail. (Checks payable to PCA-Chicago Region) Please pay by check.
To: Michael Gallagher 2418 N. Seminary.
Chicago, IL. 60614
Email: autocross@pca-chicago.org
Questions? call 773-929-8108

Driver 1 _____ Member/Guest _____ Phone Number _____
Car Model/Number _____

Driver 2 _____ Member/Guest _____ Phone Number _____
Car Model/Number _____

Total Enclosed _____ Please be prepared to display a valid driver's license

If you don't pre-register, which would save time, please pay by check at registration to speed the event up.
Day of the event questions-call Shawn Young-630-205-0055

LEADERS IN SALES, DEVELOPMENT AND CONSULTING

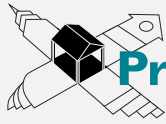

Property Consultants

Peter Sygieda

Consultant

www.propertyconsultants.com
psygieda@propertyconsultants.com

1205 West Adams St
Chicago IL 60607
Tel 312 733 4444
Dir 312 492 3225
Fax 312 492 3425

914 Limited

Maintenance, repair, restoration,
track preparation, new and used parts
exclusively for your 914
Brad Mayour, PCA since 1974
Peoria, IL. 309-694-1797
veldiadv@midwest.net fax:309-698-2203
Pickup and delivery available

R.A. Adams ENTERPRISES, INC.

2600 W. RTE. 120, MCHENRY, IL
(3/4 MILE EAST OF FOX RIVER)

(815) 385-2600
www.raadams.com

- TRAILERS • HITCHES •
- TRUCK EQUIPMENT •

- Full Service / Electrical
- Custom Paint / Graphics
- Full Line of Accessories

OPEN: MON-FRI 7:00 - 5:30
SATURDAY 7:00 - 1:00

- OVER 400 TRAILERS IN STOCK •
- FINANCING & NATIONWIDE DELIVERY AVAILABLE •
- FAMILY OWNED & OPERATED FOR OVER 45 YEARS! •

MANNY'S

Servicing, modifying, racing and restoring

Porsche cars since 1964

708-333-6606

By appointment only

WE DO IT RIGHT THE FIRST TIME!



Fischer Motors, Inc.

SPECIALISTS IN COMPETITION PERFORMANCE SERVICE

- High Performance Engine Work
- Hunter Wheel Alignment
- Race Suspension Tuning & Weight Balancing
- Transmission & Brake Conversions

Besides all sport related upgrades, we are a repair facility for German cars.

PORSCHE MERCEDES BENZ BMW VOLKSWAGEN AUDI

908 S. Northwest Highway (Rte. 14)
Between Lake Cook Roads & Dundee Road
Barrington, Illinois 60010
(847) 304-8822 - 8823

Weekdays 8 AM - 5 PM

Saturday 8 AM - 1 PM

Email Humor



Sanders, Lyn & Ragonetti Associates, Trial Lawyers

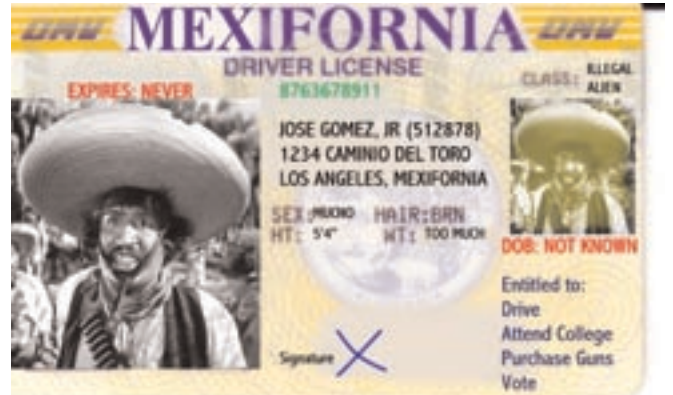

California decides to issue DL to all illegal aliens





The sounds you'll hear are echoes of Sebring.

The legendary heritage of Porsche can be heard from raceway to roadway all summer long.
Good luck from Porsche Cars North America to all participants at the 11th Annual Club Race.



PORSCHE

Octoberfest 2003

The event you've been waiting for.

Two days at Blackhawk Farms.
Drivers Ed, Germanfest and Pig Roast.

October 4th, and 5th

Yes it's that time of year again and we are back to the two day Drivers Ed. format to give you maximum track time. You will enjoy the Saturday night Pig Roast along with the German Oompah music at nearby Williams Tree Farm. Sunday offers a trackside Beer and Pizza party.

This is not a novice driving event. You must have experience to drive. All track rules apply. Mandatory clothing for all drivers at this event includes: a Snell SA 1995 or 2000 Helmet, long sleeve cotton shirt, long pants, socks, all made of non-synthetic materials, and closed toe shoes. Recommended but not mandatory are: driver's suit, driving gloves, driver shoes and a protective neck brace all made of Nomex or similar fire-resistant material, as well as a mounted fire extinguisher. Please check the date on your helmet now, as it will be inspected during the Tech Inspection at the track. If you and your car do not pass Tech Inspection, you will not be able to drive. You will be required to show a valid drivers license (no tickets accepted) along with a valid PCA Membership at registration.

You can save time at the track by bringing your car to a recognized Porsche Dealer or Porsche Specialty Shop for mechanical inspection and having them complete, sign and stamp the Chicago Region Tech Inspection Sheet. Review the NEW Updated Year 2002 Tech and Safety Requirements - there are changes from the prior year! Pay particular attention to specifics concerning brake pads and fluid, since Blackhawk is very hard on the brake system!

Blackhawk Concession Stand serves breakfast from 9 a.m. until 10 a.m., and lunch from 10 a.m. until 1 p.m. The Accessories Store sells gas (leaded & unleaded Race only), air, and showers all day.

Places to Stay for the Blackhawk Events:

Ramada Inn (formerly the Holiday Inn)
South Beloit, Illinois 815-389-3481
Indoor pool

The Beloit Inn (brand new)
Beloit, Wisconsin 866-362-5507
Jacuzzi/fireplaces in the rooms
also have suites special rates for the Porsche Club, No pool

Directions:

Follow I-90 W to Rockton Rd. exit.
Turn left (west) and follow Rockton Rd. 5.5 miles to Prairie Ave.
Turn right (north) on Prairie Ave. and proceed 1.5 miles to track entrance on left.
Mobil station 2 blocks south of Rockton Rd. on Blackhawk Blvd.

EVENT SCHEDULE

Saturday October 4

8-11 a.m.- Registration
8-11 a.m.- Tech Inspection
8:45 a.m.- C Driver's Mtg
9:10 a.m.- B2 Driver's Mtg
9:35 a.m.- B1 Driver's Mtg
5:30 p.m. Dinner at German-
Fest & Award
Presentation

Sunday October 5

8:00 a.m.- 5:00 p.m. - DE
8:45 a.m.- B1 Driver's Mtg
9:15 a.m.- C Driver's Mtg
9:45 a.m.- A Driver's Mtg
10:15 a.m.- B2 Driver's Mtg
5:30 p.m. Beer & Pizza at
track

Note: A block of 20 rooms has been reserved for PCA members at the Ramada Inn at a special rate.

Octoberfest 2003

Registration Form

Select the plan that is right for you. **CIRCLE** your choice and send this form and your payment to Peggy Gallagher at the address below.

Saturday Only \$170
Includes Pig Roast

Sunday Only \$170
Includes Pizza & Beer

2 Day - Saturday & Sunday \$290
Includes Both Pig Roast & Pizza & Beer

2nd Driver (family member) 50% of that days event price

2nd Driver (Non-family member) 75% of that days event price

Additional Dinners

Adult Only \$30.00
Child 6-13 \$15.00
Child Under 6 FREE

Non-Porsches are allowed except in run group A



First Driver Name

 Year/Car Make/ Model/ Permanent Car Number

 Phone

 E-mail

[] Member [] Applicant [] Guest of: _____

Class: (circle applicable) [Instr] [A] [B1] [B2] [C]

Prior Experience: _____

Second Driver Name

 Year/Car Make/ Model/ Permanent Car Number

 Phone

 E-mail

[] Member [] Applicant [] Guest of: _____

Class: (circle applicable) [Instr] [A] [B1] [B2] [C]

Prior Experience: _____

Make check to PCA- Chicago Region and Mail to:
 Peggy Gallagher 708-784-0784
 11156 Indian woods Drive
 Indian Head Park, IL 60525

CHICAGO SCENE

Editor Wanted

The club is looking for volunteer Editor.

If you have a knack for creative desktop publishing and would like to get involved with the club we would like to talk with you.

Contact Keith Clark (630) 690-3381

Barrington Coach Haus

Automobile Collision and Restoration Perfection

Since 1984

BCH specializes in Porsche Auto Body work and all German cars. We take pride in our workmanship from dings & dents to complete restoration and detailing. All work is guaranteed.

BCH is your one stop body shop!

22073 N. Pepper Road

3 miles west of Route 59 off of Route 14

Barrington, Illinois

847-382-5285

Mon – Fri: 8:00 – 4:30
Sat: By Appointment

Contact: Chuck Harley - Owner

INDIANA ODYSSEY RALLYE

(TANSTAAFL revisited)



SUNDAY OCTOBER 19, 2003

Registration opens	11:00 AM	Meet at The White Rose Inn
Driver's Meeting	12:00 PM	SW corner of Torrence Ave
First Car Off	12:31 PM	and Glenwood-Lansing Road
Rallye Car Fee	\$20.00	Tel: (708) 418-8700

Location: The White Rose Inn is at the SW Corner of Torrence Ave & Glenwood-Lansing Rd. Normal driving time 30MIN from the LOOP. Directions to the Inn: Take whatever route you need to get East Bound on Interstate 80-94 in Illinois. Torrence Avenue is the first exit. Exit Southbound onto Torrence Ave. Continue Southbound approximately 2 _ miles to the intersection of Torrence Ave & Glenwood -Lansing Rd. Enter the parking lot just South of the intersection at the sign reading " White Rose Inn Banquet Parking." The end point of the Rallye will be at the same location, The White Rose Inn. The White Rose Inn is an excellent German restaurant. I would suggest you plan to have dinner there after the Rallye.

The Rallye will be in NW Indiana and a small bit of Illinois. It will be a straight forward TSD (time speed distance) with a few tricks and traps. Most of you will have no idea where you are, I'm not sure I know. Since we are getting a late start, there will be no scheduled lunch break in the Rallye. Rolls and coffee will be provided at the start. Gasoline is slightly cheaper in Indiana so plan accordingly. There is a Speedway station about 2 miles east of the White Rose Inn, in Indiana. Questions may be directed to the Rallye Masters Helga & Jerry Meyer (219) 838-9232, e-mail Helgameyer88@aol.com

Mail registration to: Helga Meyer, 1101 Oriole Dr, Munster, In 46321

DRIVER _____ **Phone** _____ **e-mail** _____
Member ___ **Applicant** ___ **Guest of** _____

Navigator _____ **Phone** _____ **e-mail** _____
Member ___ **Applicant** ___ **Guest of** _____

Car Model _____ **Color** _____ **SOP** ___ **TOURING** ___ **NOVICE** ___ **EQUIPPED** ___

Rallye Car Fee \$20.00 Please make checks payable to PCA/Chicago Region

Quick Shots from Gingerman



Concours Judges School

Saturday, November 1, 2003

For the 5th consecutive year, the Chicago Region will be conducting a Concours Judges School at the Yanahan garages near Chicago. All members of Zone 13 who are interested in improving their judging skills for local and national concours are invited to attend. John Takehara and Pat Yanahan who are both experienced national judges and national concours winners will lead these sessions. This is an approved Porsche Club of America judge's school. We will have examples of preservation, restoration and preparation cars for training. After the training session, we will spend time on preparation techniques and will review various products that have been used successfully by our experienced staff.

The school will start at 10:00 am on Saturday, November 1st, with coffee and fresh pastries from our neighborhood bakery and will include a buffet lunch prepared by Bonnie Yanahan and her staff of volunteers. The sessions will include classroom instruction and then hands-on with as many cars as we can get into the heated garages. Pre-registration is required by October 28th so we can plan for enough space for everyone. There is no charge for this school, which is being hosted and underwritten by the Chicago Region, Porsche Club of America. Three hotels are within a two-minute drive of our home, which is located near I 294 and I 55 just southwest of Chicago.

For registration and information please contact:

Registration required by October 28, 2002

Pat Yanahan
7754 S. County Line Rd. Burr Ridge, IL 60527
Tel: 630-887-7605 Fax: 630-920-1935
Email: pyanahan@attbi.com



Concours experts Pat Yanahan & John Takehara

Name: _____

Address: _____

City: _____ State: _____ Zip: _____

Phone: _____ Email address: _____

Region: _____



Reinhard Barthel Chef & Proprietor
22-24 Calendar Court :: LaGrange, IL 60525
Ph (708) 354-5722 :: Fax (708) 354-5042

Date : Sunday November 2nd 2003 TIME:3:00 p.m

Café 36

22 Calendar Avenue La Grange IL 60525

Phone: (708) 354-5722 Fax (708) 354-5042

Price: \$45.00 Includes food, tax and gratuity.
Cocktails: Cash Bar

Don't miss out! Register today to dine on outstanding French cuisine and enjoy the day with your Porsche friends.

CHOOSE ONE ITEM EACH:

..... Cut Along Dotted Line.....

Appetizer _____

Entree _____

If you have any questions please feel free to call.

Make Checks Payable to: Chef Reinhard Barthel, Cafe 36

Send Checks to: Ilene Wostoupal

5 Harbinger Falls

Northbrook, IL 60062 (847) 291-1192

Name _____

Address _____ Telephone _____

Number Attending ____ Amount Enclosed at \$45.00 per person ____

Private Party Rooms

For 20-150 Persons

Wine and Champagne Bar ■ Gourmet Carry Out

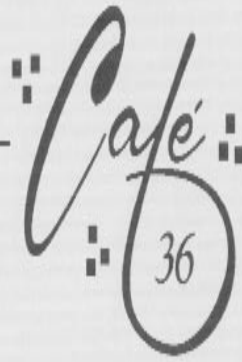

Reinhard Barthel Chef & Proprietor
22-24 Calendar Court :: LaGrange, IL 60525
Ph (708) 354-5722 :: Fax (708) 354-5042

APPETIZER

CŒUR D'ARTICHAUD ET ESCARGOT À LA PROVENÇAL
Artichoke bottom, Escargots, Provençal with Sauce Beurre Rouge and Asiago Cheese

COQUILLES ST JACQUES ET MÉDAILLIONS DE HOMARD NOUVELLE
CUISINE
Sautéed Sea Scallops and Lobster Medallions Strawberry Papaya relish,
Champagne Sauce

CHAMPAGNE ROSE SORBET

ENTRÉE

CANARD ROTI AVEC SAUCE A L' ORANGE SANGUINE ET GRAND MARNIER
Searced Duck Breast with Blood Orange and Grand Marnier Sauce

or
TOURNEDOS DE BOEUF BÉARNAISE
Broiled Filet Mignon with Sauce Béarnaise

or
TOURTEAU À LA FORESTIÈRE
Sautéed Crab Cakes with Shiitake Mushroom , Capers and Sauce Beurre Blanc

SALADE MAISON

CAFÉ CRÈME BRULÉE

Coffee and Kahlúa Flavored Custard with a Caramelized Sugar Crust

CAFÉ - THÉ

Private Party Rooms

For 20-150 Persons

Wine and Champagne Bar ■ Gourmet Carry Out

EUROSPORT *Racing*



**PORSCHE :SERVICE
:PARTS
:ROAD RACING**

**We Specialize in
Keeping Your Porsche
At It's Peak of Performance.**

- Street, Autocross & Race Car Prep
- Engine Development & Dyno Testing
- Performance Modifications & Tuning
- Motec Fuel Injection & Data Logging Installation & Support
- Transport & Support for Driver's Ed & Club Racing Events
- Custom Exhaust & Tuning
- Alignments & Corner Balancing

**Ask Us About Our
Reduced Labor
Rate
For Winter Projects
Or Major Overhauls**

**Winter
Storage?**

Some Spaces
Still Available

We Also Carry
MOTEC Systems
Hoosier Tires
Recaro Seats
Fikse Wheels
JRZ Shocks

Team Eurosport Wins At Gingerman 2003

ENDURO

JASON BROWN: 1ST - GT-2S
3RD OVERALL
BO KROCZEK: 1ST - GTP-2
4TH OVERALL
GARY KNOBLAUCH: 1ST - GT-4S
BILL ECONOMOS: 1ST - C
ROB KING: 1ST - D
CHRIS INGLOT: 1ST - F
BOB KLASKIN: 2ND - E
ERIC CYRANSKI: 3RD - C



SPRINT

GARY BOSS: 1ST - GT-4R
2ND OVERALL
TIM MCKENZIE: 2ND - GT-4R
3RD OVERALL
BO KROCZEK: 1ST - GTP-2
4TH OVERALL
ROB KING: 1ST - D
WORKER'S CHOICE
BILL ECONOMOS: 1ST - C
JEREMY GOLDBERGER: 2ND - C
NICK BRENKUS: 1ST - F
CHRIS INGLOT: 2ND - F

**midwest
EUROSPORT**

104 W. IRVING PARK RD. BENSenville, IL 60106
PHONE: 830-595-5577 FAX: 830-595-8096

WWW.MIDWESTEUROSPORT.COM

Save this date
November 9th 2003

FALL TECH SESSION

Where: The Exchange
2300 Skokie Valley Road
Highland Park, Illinois
847-266-7700

What: Four Wheel Dyno Testing and Demo
Safety and Tech Update
Tire Selection Talk

When: November 9, 2003

Time: 10am-4pm

Time Table:

10-4 PM Dyno Testing available
10-1 Registration
12-1 Lunch
1-2 Dyno Demo and Talk
2-2:30 Safety and Tech review
2:30-3:15 Tire Talk
3:15 Door Prize Raffle

We are very lucky to have The Exchange offer Four Wheel Dyno Testing for your car at \$125.00 each car for three runs, front, rear, or both available. A major discount from the normal \$300.00 cost.

First 10 cars that sign up by calling THE EXCHANGE have an appointment time. A special drawing will have one of the ten be able to receive a \$75.00 refund on the cost.

Come and be social, learn new things, get your car tested

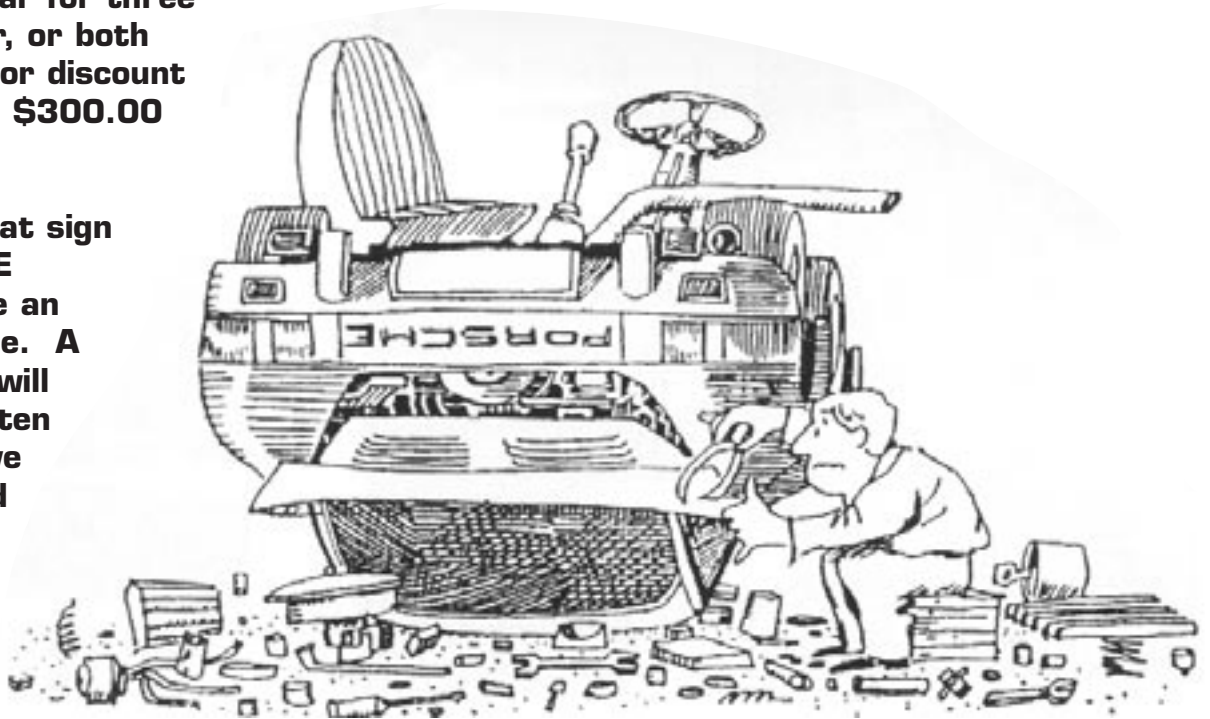

Call our host Shawn Young, The Exchange, 1-847-266-7700 to schedule your Dyno Test on a first come first serve basis. This is a great opportunity to test your car.

SUPPORT OUR Advertisers IN THE SCENE - Come and enjoy.

Competition is Good (Autocross III)

(July 27, 2003 Melrose Park, IL)

By: **Anthony C. Janairo**

The weather was muggy and warm in the morning, threatening rain at anytime. However, by the time the second group hit the grid, the temperature was 10 degrees cooler and the humidity dissipated. When the first driver was sent off onto the course, I counted about 3 dozen cars with about 4 dozen drivers. Due to the stormy skies, this was a small gathering for an Autocross event. But small groups mean a quick event. First drivers were off at about 10:45 and the course was cleared and the awards were handed out by 3:00.

It was great to see some novices as well as a few DE-ers out at the event. We had some nice cars in the paddock besides the Porsches: BMW M3, Subaru WRX, Cooper Mini, Audi TT and a few Miata's. They were all ripping up the course as well as they could keeping up good competitive times with the lot of us. Initially, to my pleasure (later to my chagrin), there were two other Boxster S's running. Competition is GOOD! Both were well prepared and treated to some of the finest options. Unfortunately for Rick, the other Boxster S driver, and me, Ed Russ has started to campaign in his M030, 18" wheeled cone eating Boxster S. He beat me by 2 _ seconds. Well, Ed does have over 25 years experience on me (while I have about 100+ pounds over him as well).

For the first run group, I was supposed to 'rest', but it had been two months since my last AX and I needed to participate, so I ran numbers from the timing van. I figured that the FTD of the day would be in the low 40's and that I would be happy with a time in the 44's. I never broke 45 seconds. The fastest time that I saw was in the sub 40's, but the three killer letters "DNF" adorned the last line of the timing slip. When I handed to Tony Kufous, he suspected that he hit a cone on the back straight.

THE competition of the day was for Fastest Time of the Day (FTD) and the level of competition at today's Autocross was something for the history books. FTD was determined by just 0.032 seconds. Tony Kufous, the veteran autocrosser, in his tried and true modified 911 RS, has always been in the sights of Shawn Young, the "modern era" autocrosser in his 1999 Boxster. Today, Shawn reached that goal. Shawn quipped that he and the Boxster have become "one". Is it Tony's turn to acquire a vehicle from the "modern era"?

Think you've maxed-out your Porsche's ability on the Autocross course? At my first Autocross in 2001, Shawn Young co-drove my Boxster S. Shawn demonstrated what my car is capable of doing. He took third fastest time on the day on that wet September day. It is not the car; it is the driver's experience. Nothing beats seat time, so keep attending the events and your car will be one of the fastest. If I'm going to beat Ed Russ, I guess I need to hit some SCCA AX's (with their 200+ drivers running cars solid from 8:15 until 5PM) to get that valued seat time. We'll see what happens at Autocross IV on August 10th.



*Jason Brown, at Gingerman.
Photo by Jason Meredith of Midwest Eurosport*

The Cuneo Concours d'Elegance III

Story & Photos by Pat Yanahan
Contributors: Mark Roter, Van Miller, Russ Pesko

The Cuneo Concours is now history and it will go

down as one of the biggest and best shows that we in Chicago have organized and executed with perfection. Over 100 show cars attended at the Cuneo Estates in Vernon Hills, Illinois making it the third consecutive year that the Chicago Region has volunteered to run this event. Architect Benjamin Marshall designed this mansion in 1914 for Samuel Insull, Founder of Commonwealth Edison Company and partner of Thomas Edison. John Cuneo purchased the Mansion in 1937 and it remained the Cuneo family home until 1990. The venue provided the cars to be presented in the gardens surrounding the mansion.



Dan Gallagher organizing the final judging



Best of Show – 1934 Packard

Since Chicago does not have an event like the Amelia Island or Meadow Brook Concours we decided to make this not just a Porsche Club event but also one that would be open to all classics. When the Chicago Region was originally invited to hold one of its regular summer concours at the Cuneo Estate three years ago the only demand we made was that the proceeds of the event go to a charity of our club's choice. This year it was Lamb's Farm and Ken Lattur from their Board of Directors was one of our final judges.

This year we had over 40 Porsches and over 100 cars representing all marques. Without a doubt the quality of the show cars this year was the best yet. With every thing from stately Rolls Royces to exceptional American brands, the early and mid 1900's were well represented with finely prepared show cars.



Lori Cappetta, scorekeeper and Judge Peter Martin



April and Mike Milhouse working on those last details



Frank Creamer getting his teeth into it

We still judge Porsches to Chicago Region standards and then pick the best from Porsche and non-Porsche categories to compete among the top 30 finalists. Both Ed Leed and Jeff Girard's racecars as well as Bob Follmer's 356 moved to the final judging field.

Dan Gallagher directed the final judging team (in Tuxedos) to pick the best. This year Best of Show was a 1934 Packard shown by Dennis Sobeski from Downers Grove. Even the very critical Porsche crowd admitted that it was deserving of the top honor. It was remarkable that Dennis had restored this Packard doing all of the restoration work including final painting himself in the back garage.

Most importantly we thank over 40 volunteers who worked from 7:30 in the morning until final trophy presentations at 3:30. Spectators and event exhibitors do not see the incredible effort that it takes to run a show of this size and quality. Without their help we could not have made this what is becoming the premier Concours in the Midwest.

Porsche Cars North America was our prime sponsor this year with an exhibit by The Exchange of new Porsche toys. Doug Battie our Midwest representative from PCNA was one of our final judges and presented \$1,000 in gift certificates to the winning finalists. Exhibits by North Shore Sports Car and shirts by Great Lakes added to the interest of spectators

See you next year on August 15, 2004.





The Cuneo Concours Results

Class A		Points	Name	Porsche	Year
	1st	43	Follmer, Robert	356 B	1960
	2nd	32.5	Drury, Jim	911 Cab	1988
Class B	1st	45.5	Slack, David	911 Targa	1974
	2nd	44.5	Buss, Kevin	911 Cpe	1971
	3rd	41	Milhouse, Mike & April	993 Carrera	1996
	4th	40.5	Leed, Ed	911S Cpe	1969
	5th	39	Bean, Ron	911	1986
	6th	38	Laurie, Rich	993	1998
	7th	37.5	Ross, John	911 RSA	1993
	8th	36	Collura, Sam	944 Turbo	1989
	9th	35.5	Giannini, Anthony	911	1996
	10th	34	Larson, Van	996T	2002
Class C	1st	43.5	Dusek, Frank	951 Cpe	1986
	2nd	41.5	Folkerts, Jeff	930 S Cpe	1987
	3rd	40	Haas, Michael	996	1964
	4th	40	Macak, Joe	911 Targa	1988
	5th	39	Miller, Van	911	1974
	6th	37.5	Diwik, John	Boxster	2000
	7th	37.5	Jacisin, Cindy	968 Cab	1992
	8th	34.5	Gallagher, Daniel	Boxster	2003
Class D	1st	41.7	Creamer, Frank	911 C2	1991
	2nd	40.6	Dirks, Robert	911 Cpe	1990
	3rd	39.9	Roter, Mark	911 Turbo	1985
	4th	39.5	Hutton, Maureen	924	1977
Class E	1st	27	Matta, Jerry	911 Cpe	1973
	2nd	26.5	Cook, Robert	911 Cpe	1988
	3rd	25	Curtis, Tim	356 Cpe	1965
	4th	24.5	Jacisin, Jim	Boxster	1999
	5th	19.5	Lichtenstein	968 Cpe	1993
	6th	19.5	Tiller, A.J.	930 Cpe	1989
	7th	14	Markese, Mark	944 Cpe	1986
Novice	1st	39.5	Girard, Jeff	944	1985
	2nd	39	Thomas, Wade	912 Cpe	1966
	3rd	37.5	Dorfman, James	911 Cpe	1974
	4th	36	Harris, Charles	911	1994
	5th	34	Jezl, Ron	911 C4S	2003
	6th	32	O'Brien, Mark & Sonia	911 Targa	1988

AUDIO... VIDEO... HOME THEATER!

**FREE
IN HOME
CONSULTATION**



**We Can
Design A
Custom System
For You**

- Big Screens
- Home Theater
- HDTV Satellite
- Speaker Systems
- Home Audio
- Plasmas
- DVD Players
- Receivers
- Projectors

**VISIT
OUR
SUPER
SHOW
ROOM**

*"For All Your Home Theater Needs...
Satisfaction Guaranteed!"*

Sound & Video

CONSULTANTS



Monday - Friday
11 a.m. - 7 p.m.

Saturday
10 a.m. - 4 p.m.

Closed Sundays

**96 W.
Northwest Hwy.**
*Clocktower Plaza
Palatine
(corner of Smith & 14)*

847 776•1611

Body Werks of Barrington

**For the Finest in
PORSCHE, MERCEDES and BMW
Work and Painting**

Desi Vinczen • 126 Cook Street • Barrington, IL
847-381-9144

The 2003 PCA Chicago Region Dinner Dance and Awards Presentation

Saturday Evening, December 13, 2003

6:30 pm - Midnight

Skokie Country Club

500 Washington Avenue
Glencoe, Illinois

6:30 - 7:30 pm	Cocktails and Hors d'oeuvres
7:30 - 9:00 pm	Dinner and Awards Presentation
9:00 pm - Midnight	Dancing

Music for the evening will be provided by the Brian Patti Orchestra

Open Bar 6:30 - 7:30 pm
Cash Bar 7:30 pm - Midnight

Entree choices:
Beef Filet Grilled Salmon
Chicken Oscar Vegetarian

\$65.00 per person Reservations Required* Black Tie Optional

Reserved seating is available for full tables of eight No cigars

Name Entree choice

Name Entree choice

Contact phone e-mail

Please reserve table of eight for: _____

\$ 65.00 per person Please make checks payable to PCA Chicago Region Total enclosed \$ _____

*No reservations or cancellations after December 3, 2003

R.S.V.P.

Susan Shire 847.272.7731
1897 Mission Hills Lane
Northbrook, IL 60062

Helpful Information for the Dinner Dance

Overnight Accommodations: Please mention the Porsche Club when making reservations to obtain special rate. The cut-off date for the special rates is November 11, 2003.

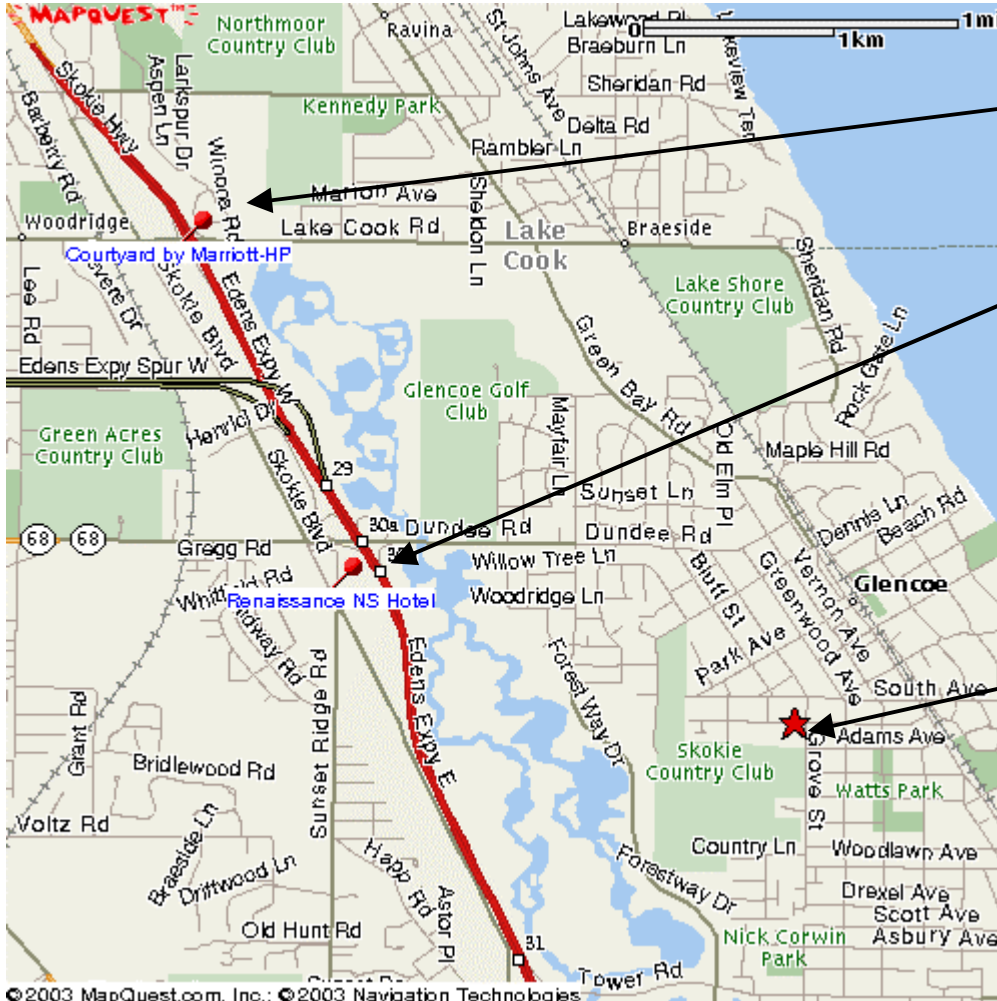

The Courtyard By Marriott-HP is located at 1505 Lake Cook Road (at Route 41) in Highland Park, IL 800.321.2211 \$89.00

The Renaissance Chicago North Shore Hotel is located at 933 Skokie Boulevard (Dundee Road and Edens Expressway/I 94) in Northbrook, IL 800.468.3571 \$65.00

The Skokie Country Club (847.835.0600) is located at 500 Washington Avenue in Glencoe, IL, just east of the Edens Expressway/I 94), between the Tower Road and Dundee Roads exits. The Club House parking lot is on the corner of Washington Avenue and Grove, with the entrance on Washington Avenue.

DIRECTIONS to THE SKOKIE COUNTRY CLUB:

From the North: Take Rt. 41 (which becomes the Edens Expressway/I 94) and exit at Tower Road. At the exit ramp Stop Sign, turn right. At the next Stop Sign (Tower Road) turn right (East). Take Tower Road to Vernon. Turn left (North) on Vernon to Washington Avenue. Turn left on Washington Avenue to Grove.

From the South: Take the Edens Expressway/I 94) and exit at Dundee Road East. Turn right on Grove to Washington Avenue.

From the West: Take Dundee Road (East) to Grove. Turn right on Grove to Washington Avenue.

OR

Take Willow Road (East) to Green Bay Road. (Willow Road is an exit off I 294). Turn left (North) on Green Bay Road (through Winnetka and Hubbard Woods) into Glencoe (where the street name will change to Glencoe Road). Turn left on Washington Avenue to Grove.



O'HARE

auto body

The finest in auto body repair from street to full race, aero kits to custom body design, and detail work to complete paint jobs. We have superior equipment and an expert team dedicated to customer service for the distinguished auto enthusiast.

**Celette Dedicated
Fixture Bench**

**Pro Spot Resistance
Spot Welding**

Full Lifetime Warranty

**Expert Insurance
Claim Processing**

**Onsite Towing and
Rental Service**

**Certified Automotive
Restoration Technicians**

I-Car Certified

Glasurit Authorized Refinisher



**O'Hare Auto Body Ltd.
1316 W. Irving Park Road
Bensenville, IL 60106
Ph: (630) 766-6668
Fx: (630) 766-6663**

PCA-CHICAGO REGION OFFICIAL BOARD ELECTION BALLOT

Below is the official Ballot for the 2004 Board of Directors. This ballot is in accordance with our By-Laws, Article VI, Section 2. By tradition, we leave a place for write-in candidates. Only active family members may vote and all ballots must be signed by the voting member. All ballots must be received by the Secretary or post marked no later than November 1, 2003.

		Nominating Committee Candidates		WRITE-IN
President:	[]	Jim Jacisin	[]	_____
Vice President:	[]	Chris Inglot	[]	_____
Treasurer:	[]	Jack Stephensen	[]	_____
Secretary:	[]	Ed Barnicle	[]	_____
 Vote For Two Directors:				
Director	[]	Mary Ann Nowakowski	[]	_____
Director	[]	Todd Conforti	[]	_____
Director	[]	Steve Rashbaum	[]	_____

Member's Signature: _____

Date: _____

Member's Name (printed): _____



		Nominating Committee Candidates		WRITE-IN
President:	[]	Jim Jacisin	[]	_____
Vice President:	[]	Chris Inglot	[]	_____
Treasurer:	[]	Jack Stephensen	[]	_____
Secretary:	[]	Ed Barnicle	[]	_____
 Vote For Two Directors:				
Director	[]	Mary Ann Nowakowski	[]	_____
Director	[]	Todd Conforti	[]	_____
Director	[]	Steve Rashbaum	[]	_____

Member's Signature: _____

Date: _____

Member's Name (printed): _____

This ballot is pre-addressed. Appropriately fold, tape, stamp and mail it after voting.

MARK YOUR BALLOT AND SIGN.

**NOTE: THIS BALLOT CAN BE USED FOR
TWO VOTING MEMBERS PER HOUSEHOLD.**

TEAR OUT, FOLD, TAPE AND MAIL IMMEDIATELY.

POSTAGE REQUIRED!

Fold Here

Mary Anne Nowakowski
PCA Chicago Region Secretary
527 South Rammer Avenue
Arlington Heights, IL 60004

PLACE
STAMP
HERE

Mary Anne Nowakowski
PCA Chicago Region Secretary
527 South Rammer Avenue
Arlington Heights, IL 60004

PCA - Chicago Region Board Meeting Minutes

AUGUST 8, 2003

Voting Members Present: K. Clark, J. Jacisin, M. Nowakowski,
J. Stephensen, P. Hackenson, S. Young,
K. Pesavento, E. Barnicle

Coordinators Present: V. Miller, T. Duckett, P. Harwood,
T. Harwood, D. Gallagher, J. O'Keefe, T. Conforti,
P. Yanahan, E. Leed

Members Present: D. Fiedler, R. Gunderson, M. Bour

Meeting Called to Order by K. Clark at 8:00 PM at the Park Ridge VFW Hall, Park Ridge, IL

Secretary: M. Nowakowski

Presented minutes from July 11, 2003 Board Meeting.
Motion to Accept Minutes: E. Barnicle Second: P. Hackenson
Approved: Unanimously

Treasurer: J. Stephensen

Presented Chicago Region Financial Statement dated August 7, 2003.
Motion to Accept Financial Statement: M. Nowakowski Second: E. Barnicle
Approved: Unanimously

Autocross: S. Young/M. Gallagher

Presented by S. Young. An alternate date for the "Run for Fun" will be proposed at a future Board Meeting.
General discussion regarding conflict with the Naperville Grand Prix Charity event.

Road America: P. Hackenson/K. Clark

Presented by P. Hackenson. Currently 180 club racers and 80 Drivers' ED participants are registered. Rooms are still available. All preparations are on target including shirts and awards. Sponsorship dollars and awards are incoming. Sponsorship is down slightly from last year.

Blackhawk Farms: D. Gallagher/P. Hackenson

Presented by D. Gallagher. Currently 33 vehicles are pre-registered for the August 13 event. Instructors are required for this event. The Octoberfest Blackhawk planning is ongoing.

Insurance: K. Clark

Insurance coverage for all August and September events has been procured.

Concours: J. Jacisin/P. Yanahan

Presented by P. Yanahan. Over 60 cars are pre-registered for the Cuneo Concours on Sunday, August 17, with 100-150 cars expected. Bosch, PCA, Cadillac, Morgan and Great Lakes Apparel are among the sponsors for this event. Trophies have been donated by Bosch Company. PCNA has contributed gift certificate awards. Shirts are available for this event. The designated charity is Lambs' Farm, as chosen by Cuneo Estates.

Rallye: K. Pesavento/T. & P. Harwood

Presented by P. Harwood. The July 13 Lake County Rallye was attended by 31 cars, all of which finished the rallye. The preparations for the September rallye are completed.

Social:

T. Duckett answered K. Clark's request for social events by arranging two upcoming events. A social event has been planned for Sunday, October 26 at Weber Grill in Lombard. A BBQ buffet will be available for \$15 per person beginning at 12 PM. A cash bar will be available. The Bears vs. Lions game will be televised, and the Weber Grill Chef will give grilling tips at half-time. A tentative social event on February 14, 2004 at Shaw's Crabhouse in Schaumburg will be finalized in 2004.

Membership: V. Miller

Presented 14 new members for July, and 5 new members for August. General discussion regarding membership dues.
Thanks to E. Leed for assistance in computer conversion.

Safety: T. Conforti

Gingerman 2003 Drivers' ED was incident free.

Technical: T. Duckett

The Porsche Exchange and Shawn Young will host the Fall Tech Session. The key highlight for this event will be a demo and opportunity to run your car on the unique four-wheel dyno. Information for this event will be in the upcoming Scene. Tech at the Gingerman event ran smoothly.

Goodie Store: K. Hackenson

Presented by P. Hackenson. The Goodie Store will be transferred to another coordinator.

Charity: J. Drury/K. Knott

Presented by K. Clark. The Naperville Grand Prix event, on September 28, is gathering steam and will be well attended. An area for parking of Porsche's has been procured, with a parade lap around the track. Potters Mexican Bar has been chosen as a central PCA Chicago Region gathering place.

Historian: J. O'Keefe

The Club's historical archive has been moved to a storage location in Hinsdale.

Webmaster: G. Gulik

Presented by M. Nowakowski. TRAC 2003 DE and CR information and participant listings are included on the webpage.

No Report

President: K. Clark

Vice President: J. Jacisin

Gingerman: J. Girard

Timing & Scoring: C. Bittman

Continued on page 34

Board Meeting Minutes

Continued from page 33

Chief Driving Instructor: J. Ruther
 Chicago Scene: S. Adleman
 Advertising: S. Shire
 Property: E. Leed
 Sponsors: M. MacKonkie
 Photography:

Old Business: None Heard

New Business:

Presented by E. Leed. General discussion regarding Scene charges to out-of-region recipients.

Presented by P. Yanahan. On July 29, 2003, the duly appointed Nominating Committee met to address the slate of officers and directors to be submitted to the membership for consideration for the upcoming election. The Nominating Committee, consisting of K. Clark, J. Drury, T. Duckett, S. Shire, and P. Yanahan met at the home of S. Shire. After an excellent dinner hosted and prepared by S. Shire, the Committee officially convened its meeting at 7:30 PM. The following slate of officers and directors are presented:

- President – J. Jacisin
- Vice President – C. Ingot
- Treasurer – J. Stephensen
- Secretary – E. Barnicle
- Director – M. Nowakowski
- Director – S. Rashbaum*
- Director – T. Conforti

*Please note that S. Shire abstained from the vote for S. Rashbaum.

The Committee agreed unanimously to the above slate and adjourned at 8:50 PM.

Motion to Adjourn: E. Barnicle Second: S. Young Approved Unanimously

Adjournment: 8:42 PM



Formerly Apple Mortgage, Inc.
Michael Gallagher
 Senior Loan Officer

750 North Orleans, Suite 101A • Chicago, Illinois 60610
 Direct Phone: 312.932.2333 • Office Phone: 312.932.2300
 Cell: 312.919.8108 • Fax: 312.337.2534
 Email: mikeg@airmortgage.com

2003

Shawn Young
Sales Consultant

The Porsche Exchange

2300 Skokie Valley Rd.
Highland Park, IL 60035



PORSCHE

Certified
Sales Professional

Phone: 847-266-7000
 Fax: 847-266-7710
 Cellular: 630-205-0050
 Email: shawn@porsche.com

The Midship Report: Retractions & Contractions

Continued from page 5

Chicago Vice President turned up at the Cuneo in a 1999 Ocean Blue Boxster. Jim was previously behind the wheel of a Guards Red 968 when threats of major mechanical expenses 'persuaded' him to come to OUR side. Jim made his first contribution to our cause and I immediately promised to steal his idea and publish it as my own...DOH! Floor mat protectors. Do you have the OEM Porsche Floor mats? Were you as STUPID as I was to pay almost \$100 for them? If you answered yes (at least to the first one), there are a few options: You can go out and get a new OEM set every 2 or 3 years; You can get a set from Lloyd's (also around \$100, but far superior in quality); Or you can put some protectors over the ones you have. In this photo (4), Jim fashioned his own protectors using non-slip (office) chair mat that you can get from Home Depot and the like. A very inexpensive and very durable solution. Welcome to the Team, Jim.



And speaking of Cuneo...

Were you there? Lots of Porsches were—both in entrants (photo 5) and visitors. This may have been the best showing yet in terms of Porsche participants. Sadly, the rest of the field wasn't as filled out as the previous year. Only afterward did I hear that a MAJOR historic car show was scheduled up against us on the same Sunday. Scheduling issues aside, there are still far too many car people out there that don't know about this event and should. Next year, we all need to do a bit of PR for this. If the local suburban (Elmhurst, Lombard, Berkley) car shows can attract several hundred cars on a week night, we should be able to focus some of that interest into our event.



MIDSHIP TOURIST-TROPHY

And the winner is... Jim Caruso. The look of shock is SO worth it. Jim made it to the Maywood Park Autocross with his '99 Ocean Blue Boxster (also wearing the 10 spoke wheels that I covet) and for the very reason of participating, Jim is shown here (photo 6) accepting his MidShip TT prize. Who's next?...like the slogan says: "You must be present to win".

Pride, Performance, Passion



Select Pre-Owned Sports Cars

2215 W. Belmont Avenue
Chicago, IL 60618
773.325.1690
midwestperformancecars.com



Address Change?

Name (s):

Old Address:

NEW Address:

Home Phone:

Fax:

Work Phone:

E-mail:

Mail, Fax or E-mail the above information to: Debbie Leed, 37 Lakeview Drive, Barrington, IL 60010-1949 FAX-847-382-3562 (8:00 a.m. until 8:00 p.m. only), leedlast@hotmail.com

WELCOME TO OUR NEW MEMBERS

August 2003

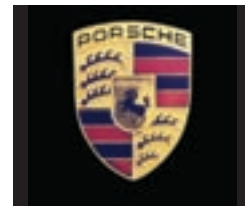

Total Members: 1511, Transfers into Region: 7, Transfers Out: 7

New Members

Mark & Isabel Anderson St. Charles, IL 1975 914	Gregory & Linda Guy Chicago, IL 2003 911 Coupe	Michael & Laurie Kibler Oak Park, IL 1995 911 C4 Coupe	Roy & Heidi Schoeneck Naperville, IL 1990 Carrera 2 Coup	David Hirschfeld Wilmette, IL 1995 911
Matt Borowski Chicago, IL 2003 Boxster S	Victor Grzebicki Glenview, IL 1995 911 Cab	Tom Kowalski Arlington Hts., IL 1987 944 Turbo Randy & Tina Looke Palatine, IL 1986 911 Coupe	David & Nancy Schultz Hanover Park, IL 1983 928S Coupe	Jill Janeski Chicago, IL 2002 Boxster
Paul & Olga Dolinar Libertyville, IL 2002 Boxster	Jeff Hall Batavia, IL 2003 Boxster S	Alex Nash Gurnee, IL 2004 GT3 Coupe	Ron & Kim Taylor Romeoville, IL 1984 944 Coupe	Rob King Elmhurst, IL 1982 911SC
Robert & Lynne Donald Lynne Donald Arlington Heights, IL 1988 911 Turbo Cab	Mike Hasanov Deborah Hasanov N. Barrington, IL 1987 911 Cab	Piotr Niklinski Mike Patton Hanover Park, IL 1994 968 Coupe	Larry & Amy Thalmann Glenview, IL 1986 930 Coupe	Amy Kristoff Crown Point, IN 1994 911
Scott & Sanders Frank Chicago, IL 1993 928 GTS	John Hayden Winnetka, IL 2002 911 TT X50	Christopher Ross Theresa Ross Chicago, IL 1984 911 Turbo	Tom & Pam Turner Rockford, IL 1986 951 Coupe	Ray Quick Arlington Heights, IL 1987 911 Coupe
Michael Friedlander Elizabeth Friedlander Chicago, IL 1998 Boxster	John Kenna LaGrange, IL 1980 911SC Targa			

Transferees

Morgan Raines
Hudson, IL
2000 Boxster



- **Focus Group Research** *(a tool to help define marketing plans or new product ideas)*
- **Customer Satisfaction Surveys** *(what better way find out what customers think)*
- **Mystery Shopper Research** *(used to evaluate salesperson performance.)*
- **Music Listeners Testing** *(useful in improving your stations market share)*
- **Taste Testing** *(a change of ingredients can save millions if it doesn't effect taste)*
- **Product/Website Usability Research** *(Is your product or service as easy to use as you think?)*
- **Jury Research** *(Test your strategy before it is time for the verdict)*

For more information call us at 847-390-8666 or
visit our website www.preres.com.

Spare Parts

This section is a compilation of short pieces from our region, various web sites and other regional sources.

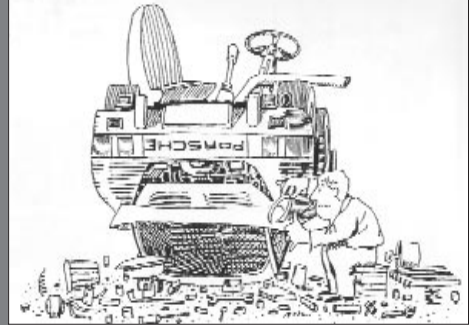

Porsche Certified Pre-Owned

ATLANTA, GEORGIA, June 25, 2003 — Porsche Cars North America Inc. (PCNA) this month launched Porsche Approved Certified Pre-Owned, a program intended to bring younger buyers to the Porsche brand, strengthen brand loyalty and awareness, and increase the value of pre-owned Porsches. "Response has been extremely positive," said Peter Schwarzenbauer, PCNA President and CEO. "This is a very agreeable situation for customers and dealers. Dealers can increase traffic and build relationships with new customers, while the customers get a car they can trust from a source they know."

Key elements of the program are a 100-point mechanical and appearance inspection backed by the manufacturer's limited vehicle warranty extension and roadside assistance program. In addition, Porsche Financial Services, Inc. (PFS) will offer new-car financing and lease rates for eligible customers and vehicles.

New Porsches have a four-year/50-thousand-mile (80-thousand-kilometer) warranty. The program extends the car's original warranty by an additional two years or 50 thousand miles (80 thousand kilometers). For those cars that are out of warranty, the plan covers them for two years or up to 100 thousand total miles (160 thousand kilometers).

PCNA will support the program and dealers with a marketing and advertising program, including point of sale material, national newspaper and magazine advertising, and an on-line campaign linked to a pre-owned vehicle locator. PCNA will also offer training for dealers.

Porsche Approved Certified Pre-Owned applies to all Porsche models originally sold through PCNA authorized dealers and put into service within the last eight years. Only 1998 and newer models are eligible for PFS financing and leasing.



New Cayenne Coming to NA

ATLANTA, August 27, 2003 — Following the successful worldwide launch of the Porsche Cayenne — success measured in many ways including two top magazine awards and more than 7,300 Cayenne S and Cayenne Turbo V8 models sold in North America to date — Stuttgart, Germany-based Dr. Ing. h. c. F. Porsche AG today announced the introduction of a third Cayenne model, which will be powered by a six-cylinder engine. It will debut at the Frankfurt Auto Show in September and subsequently go on sale in Germany and Europe.

Once it is introduced in North America during the first half of 2004, this latest Cayenne model — named simply Cayenne — will feature the same standard-setting on- and off-pavement capabilities of its V8-powered siblings while offering its own impressive performance figures. It can accelerate from 0 to 62 mph (0 to 100 km/h) in 9.1 seconds and has a top test track speed of 133 mph (214 km/h).

The Cayenne will have a V6 engine, the first ever offered in a Porsche. Engineers at Porsche further developed the stock engine and modified it for the most severe off-pavement driving conditions. It has four valves per cylinder and produces 247 horsepower (SAE) at 6,000 rpm and 229 lb.-ft. of torque between 2,500 and 5,500 rpm.

Aside from its power source, the Cayenne will offer all of the features first introduced on the Cayenne S and Turbo, including the Porsche Traction Management permanent four-wheel drive system, Porsche Stability Management and air suspension.

Since its arrival at the end of 2002, the Porsche Cayenne has been making a name for itself in the vibrant luxury sport utility segment, offering best-in-class on-pavement driving characteristics and exceptional off-pavement performance. In 2003, AutoWeek Magazine readers named the Cayenne the Best SUV/Off-Road Vehicle as part of the magazine's 14th Annual "America's Best" Survey. The Robb Report also presented its "Robb Report Best of the Best 2003" award to the Cayenne in the sport utility segment.

This latest addition to the Cayenne line-up will expand Porsche's potential customer base within the high-end SUV segment and will provide more opportunities for Porsche's 204 North American dealers.

PCA Chicago Region 2003 Tech Inspection Sheet

NAME: _____ CAR COLOR: _____ RUN CLASS: _____
 MODEL/YEAR: _____ ENG. DISP.: _____ CAR #: _____

Pass Fail

!!! TO BE INSPECTED BY ENTRANT PRIOR TO EVENT !!!

Note Driver/Run Classes: Slower, less experienced driver is Novice Class N, progressing to C, B2, to B1 to A, with A Class the most experienced and faster.

Inside

Outside

Engine

1. **HELMET, SNELL SA 95 or later required for all Track Events** including Blackhawk, Road America, and GingerMan. (Snell SA sticker must be attached inside)
- 1A. **HELMET, SNELL SA or M 90 or later required for all Autocross events** (Snell SA or M sticker must be attached inside).
2. **APPAREL** - Full-length pants, long sleeved cotton shirts, cotton socks and full coverage shoes are mandatory. Highly recommended, but not mandatory are drivers' suits, driving gloves and shoes all made of Nomex or similar fire-resistant materials. Arm restraints required for All Open Cars.
3. **SEAT BELTS** - Original factory installed belts for N,C&B2 Class. Required for all other Classes (and all B Class at Road America); Stock Seat =6- point, "H" Harnesses without Harness Bar & no "H" with Bar or Race Seat = 5/6-Point. All securely anchored, Metal-to-metal, with large diameter washers on both sides of floor mounting holes. Tunnel side belt mounting only on factory seats. Harness and Seats must be equipped the "same" for Driver and Passenger side (Instructor).
4. **FIRE EXTINGUISHER** - Recommended but not required. Securely anchored metal-to-metal in reach of driver. BC or ABC rated and fully charged. AFFF or Halon recommended.
5. **ROLL PROTECTION** - Roll Bar, Cage or Extender using "broomstick rule" Required for all A Class. The same Roll Protection is highly recommended although not required for other Classes. Any open car (no roof) must run A Class rules. Cabs must have roof in up position and sunroofs must be closed.
6. **PEDALS** - Free return and in good operating condition. Firm brake pedal.
7. **LOOSE OBJECTS** - Remove all loose items from trunk and interior, including glove compartment, door pockets, console, mats, etc. Glove box locked. Spare secured or removed (spare adds to structure to certain Porsches).
8. **AIR BAG EQUIPPED CARS** - No Obstructions in front of Air Bag (s).
9. **WINDSHIELD** - No major cracks and functional wipers with good blades.
10. **MIRRORS** - At least one side (two highly recommended) and one securely mounted rear view mirror.
11. **GAS CAP** - Gasket intact and cap tightened.
12. **RUST** - No rust or damage to suspension or chassis parts that affect the integrity of the chassis or brakes.
13. **FRONT SUSPENSION** - No excessive looseness in steering or suspension. Lower trailing arm to radius tight; Axle and shock bolt tight. Ball joints in good condition. Tie rods secure. Axle boots and oil seals in good condition. **Warning: 944/968 MUST Check Ball Joint & Control Arms for cracks and binding caused by excessive lowering, larger sway bars and track usage.**
14. **REAR SUSPENSION** - No excessive looseness. Check half shaft bolts and shock bolts. 914's check fuel pump and lines. No positive camber on any car.
15. **WHEEL BEARINGS** - Correct adjustment, check for play and proper lubrication, no damaged or burnt bearings.
16. **BRAKES** - Sufficient brake linings or pads. No rubbing, cuts or abrasions in brake lines. Check rotor condition. Brake pad thickness must be checked periodically for 2mm minimum thickness throughout the high-speed events. Make sure you start with ample brake pad material and/or bring an extra set of pads. It is recommended you start with fresh Competition pads properly bedded in.
17. **WHEELS** - No cracks. No bends. All lug nuts must have 94 - 96 lbs. torque. Valve stem must have airtight cap. Hubcaps and Center Caps must be removed.
18. **TIRES** - In Good condition. No cracks or bulges. ZR or better required (HR for Autocross only). Minimum tread depth of 3/32" on contact patch area (race tires or shaved performance tires must have at least 1/16" tread wear marker depth and No Cord Showing). Seek an experienced driver with like car/tires for hot/cold tire pressure.
18. **BRAKE FLUID** - Level up, must show in reservoir. All cars must have their brake systems flushed with DOT 4 specification or better brake fluid 90 days or less preceding the high-speed event. If another high-speed event is run less than 90 days prior to this event, then the fluid must be flushed again before running.
20. **BATTERY (IES)** - Securely fastened and in good condition. No acid leaks or corrosion. Check fuel lines under battery trays on 914's. The Positive (+) Terminal on All batteries must be covered by cap or tape.
21. **ENGINE** - Check for odd sounds and satisfactory exhaust (remember 108db limit at Road America)
22. **DRIVE BELTS** - Tight and in good condition.
23. **LEAKS** - No exhaust leaks and leaks of any fluid - oil, gas, brake, or coolant.
24. **THROTTLE RETURN** - Freely operating and good springs. Check both throttle return springs on CIS cars.
25. **BRAKE LIGHTS** - All bulbs on both sides and center brake light (if so equipped) must be functional.

Helmet Requirements!

In consideration of my participation in this event, I have checked the above items and certify that they meet or exceed the requirements. I agree to indemnify and hold harmless the organizers of the event, or their agents, with respect to responsibility for the condition and preparation of my car, or any subsequent mechanical failures or resulting damage to my car or its occupants as a result of any such failures. I acknowledge that at all times, I remain solely responsible for the safety and roadworthiness of my car.

I hereby certify that I have no physical or mental problems, which could jeopardize any others or myself if I participate in this event.

ALL OF THE ITEMS ON THIS TECH SHEET HAVE BEEN TESTED AND SERVICED AS DESCRIBED. THE TECH INSPECTOR'S SIGNATURE BELOW DOES NOT IMPLY COMPLIANCE WITH THE ABOVE AND IS ONLY AS WITNESS TO THE DRIVER'S SIGNATURE, WHICH WARRANTS COMPLIANCE.

DRIVER'S SIGNATURE: _____ DATE: _____

WITNESS TO DRIVER'S SIGNATURE (Inspector): _____ SERVICE STAMP _____ DATE: _____

Revised Feb. 9, 2003

The Mart

PCA members are welcome to place ads of a non-commercial nature at no charge in The Mart. For non-members, the non-refundable fee for this service is \$15.00 for three months, with checks payable to PCA Chicago Region. Ad material must be received by the 1st of the month for publication in the next month's issue. Publication is subject to space availability and editing. Ads to be placed after the initial three month period must be resubmitted. Please limit ads to 75 words or less.

Please see page one for submission information.

For Sale

Porsche Cars

911/912

2001 GT3 SuperCup factory car. Wht./Wht. with Series graphics. Competitively raced in the '01series as #11. Low hours, Excellent condition. Very fast and drivable. Many updates and spares. Professionally maintained. Phil Koepke, 262-243-9012, philip.koepke@micorp.com [SON]

2001 GT3 Supercup car. Rebuilt on new chassis after 2001 Supercup series; only been in 4 races since; fresh engine and transmission; PCA club race ready; 4 sets of wheels; \$89,000 Contact JD (312)282-0005; jdl@cmtkg.com [ASO]

1988 911 Targa with Carrera Sport Package. Pkg. = factory turbo body, turbo wheels, turbo brakes, turbo suspension. 39k miles \$35,000. Contact Dr. Tony Chiodo (847) 823-7100. photos <http://www.imagestation.com/album/?id=4289192053> [OND]

1988 930. Race Car 700 hp. A proven winner. Too many firsts to list. Fresh motor & trans. 935 suspension with Penske's Fabcar wing. Fully sorted, Needs nothing! 2 Workers Choice awards. 2:18 at Road America. Building new car. PRICE REDUCED (630)291-6982 glenn@thesapas.com [SON]

1988 911 Targa, Very good condition. Black w/ black leather. 97,000 miles with engine rebuild @ 70,000 by Porsche. No leaks or drips, runs strong. AC, cruise, whale tail. New YOKO AVS ES 100's, 16 in wheels. Pioneer CD. \$19,900. Call John at 847-962-7280 or jpmiller1290@attbi.com [OND]

1988 911 Cabriolet. 49,750 miles. Black ext. Maroon int. Concours ready. Weidman polished OEM rims, Yokohama AVS tires like new. All New; autoauthority chip, K&N air filter. Boge shocks. sway bar bushings and rear linkages. Blaupunkt CD stereo and speakers. 12-way drivers seat and 8-way passenger seat. Momo steering wheel. bra. factory window seals horizontal and vertical. A/C recently serviced. Rear window is clear. Top in excellent condition. Leather is soft and scratch free. Car needs nothing. \$38,000.00 invested, \$32,000.00 obo. Dave Leger 630-669-1979 or drddl@sbcglobal.net [OND]

1987 911 Carrera Guards Red & Black; Sunroof & factory

spoilers; all "power options"; Excellent Paint; leather power "sport" seats & standard leather; Nardi & original Steering Wheel; Fuchs with Bridgestone S02's; New Bilstein shocks; New Blaupunkt AM-FM-CD & original; Cover Craft Cover; 2 sets of floor mats; Bra; Tire pump; Maintenance performed by Fischer Automotive; All records available; Professionally Tinted Windows; Photos available; 79,000 miles; \$27,500; Stan 847-577-6550 (days) sclement@safemgt.com [OND]

1986 911 Carrera Coupe - red/black, excellent original condition inside and out, no modifications. 78,000 miles. Sunroof, CD player, factory short shift and limited slip diff, new clutch and synchros, recent valve adjustment, 16" Fuchs, less than 1000 miles on Bridgestone S03s. Everything works, second owner, always garaged, maintained by Midwest Eurosport. Cover included. \$23,500. Call Thad at 312-461-5739 (day) or 708-524-2748 (eve), diana@diphotography.com [OND]

1986 911Carrera Targa, Guards Red with black interior, New Paint, New Tires, New Targa Top, Whale Tail, New Radio w/CD, Interior is in great shape, one owner, runs and looks great, 120,000 mi. \$17,750 Tom @ 630-416-7859 / Futbroker@aol.com [SON]

1985 911 Turbo Red/Red, 33,900 miles, only 2 owners from new Excellent DE/street car. Many weight-reduction/performance parts Excellent condition, fast and drivable. Professionally maintained, receipts, Nadeen Koepke, 262-243-9012, philip.koepke@micorp.com [SON]

1978 911 SC Black w/ Tan leather. Turbo body Correct steel conversion. PW, Alarm, H4'S, New Suspension by Midwest Eurosport. Tuneup, New Weather Stripping, Won 2nd at Fermi Concours. Drives, handles and looks excellent. 16,900 obo. Brain 630-469-5979 [SON]

Boxster

2000 Boxster-S Biarritz White/Metropol Blue, 12,000 miles, Sport and Digital Package, 18" Wheels with Colored Crests, 6-Speed, Crests in the seat backs, car comes with color matched bra and mirror bras and factory car cover, No Winters, Little Rain, Always Garaged, Detailed engine, suspension and chassis, Needs Nothing, Absolutely Flawless! Under Warranty Until 5/04, Asking \$42,000.00 John 312-907-9823/630-904-9915 or j.diwik@comcast.net [OND]

2001 Boxster S. 16.5k mi. Black/Black/Black. 6 speed, CD w/Hi Fi Sound, 17" wheels. Flawless. \$39,900. Contact Doug at (708) 494-3684 or Doug@DougWakeley.com [OND]

1999 Boxster, Zenith Blue/Beige lthr, Blue top, Alpine cassette with 12 CD and amp, 17s, sport pkg, 5 spd, 25,000 miles, garage stored, no winters, no smoking, prof. maint. by Fischer Motors, Asking \$28,900 OBO, days 847-473-6572, eve 815-675-6136, cell 815-790-0981, jim_lewan@baxter.com [SON]

924/928/944/968

1991 944S2 3.0. Last and best of the 944s. Guards red w/black leather, two PCA member owners. 122k mostly highway miles, major maintenance by Fisher Motorsports, minor maintenance done personally. Mobil 1 since new, I've owned this car for 8 years, prior to this car a 1988 944 Turbo S, before that a 1986 944 Turbo. This is the best of them in terms of drivability, usable performance and ease of maintenance. Driven

only in good weather, many extras included. \$12,000 obo Peter K. (630) 655 6816 office or (708) 338 2384 Hm [OND]

1990 944 S2 Cabriolet: White with new blue top, blue leather interior, all original, stored winters, new rotors, brakes, custom cover, fuel pump, all receipts available, excellent condition. 89k miles. \$16,900. cell: (847) 826-4657 email: Lzdkng99@aol [ASO]

1988 944 Turbo Red/Black, mass air, arc 2 chips, garret Turbo, Fuel reg. 52lb. hr. inj., nology ign., tial wastegate w/custom control & liquid gauge, 6 pt migwelded cage, 968 fr. sway bar, w.meister adjust. rear, 600lb.eibachs front, 400lb.rear,w/reset torsion bar, bilsteins, short shifter w/momo knob, momo st.wheel, recaro seat w/5pis., recent \$3k lower end done w/re-route oil pan, camber plates, brass ball joints, 3" stainless w/orla no cat., 993 wheels w/kumos, 2 sets hoosiers. no rust CA car, \$14,500, Greg 630-674-5663, gaulner@yahoo.com [SON]

1987 944 Turbo red/black, 60,000 miles, very good condition, Brembo brakes, Koni adjustable shocks, full roll cage, 2 Recaro seats with harnesses, Fiske wheels 8.5 x 9.5, HD springs, lowered, original seats, extra tires & wheels. \$15,000. Call Bob 847-680-0136 or rostoga@aol.com. [ASO]

1986 944Turbo Red/ Black leather, excellent condition in and out. 56,00 miles, no winters, many new parts, sunroof, 5 speed, chip, records, no track, runs fantastic. \$10,900 Roger Briggs, 847-670-9304 H 847-452-0349 Cell [ASO]

Other-Cars Etc.

1999 Ducati's Limited Edition Monster Cromo 900. \$9,950. 2976 miles. It is my understanding that there are only 63 bikes of this kind in the USA. This was the first and only year for this model, call 773.960.9673 or e-mail me at carlos@segura-inc.com see photos and more info at <http://www.segura-inc.com/segura2/classifieds/cromo.htm> [SON]

1995 Audi S6: original owner, 103,000 miles, Emerald Mica Metallic with Ecu full leather, 2.2L 227 hp QUATTRO, ABS, all options including voice activated phone and 10 CD changer; replaced timing chain at 80K, dealer installed factory lowering kit, Blizzaks on factory 16 rims, Dunlop Sport 8000s on 17 Mille Miglia Porsche style rims. Serviced by Fischer Motors. Great winter car! Come this winter, this 4 door sedan will outperform anything less than a Cayenne. \$16,900 OBO. Call Bob 847-224-0313 or rlaw@core.com [SON]

1994 Mazda Rx7 Race Car ITE, 350 hp, total rebuilt engine, Excellent condition \$26000. Free track time with all purchase and invitations to Special Events at GingerMan Raceway. Call Dan 269-253-2017 [OND]

1992 Alfa Romeo 164S chip Eibach Springs, wheels and tires, gorgeous Lamborghini purple \$6700 Free track time with all purchase and invitations to Special Events at GingerMan Raceway. Call Dan 269-253-2017 [OND]

1967 BMW 2002 180 hp, Recaro's, Roll Bar, flares and a great history \$3500. 3 free nites at GingerMan Racing Call Dan 269-253-2017 [SON]

continued on page 40

The Mart

continued from page 39

1967 Jaguar XKE Roadster under complete restoration. (a new Jaguar by Tracksides Custom Works) Free track time with all purchase and invitations to Special Events at GingerMan Raceway. Call Dan 269-253-2017 [OND]

Parts

Parts for Sale. Brey-Krause harness bar for 996 (\$750) Two Simpson 5 pt harnesses (\$100 for set) Brey-Krause fire extinguisher bracket for factory seat for 996 (\$25) Two Tire Rack Porsche Cup wheels 17 X 7.5 (\$125 ea) Two Tire Rack Porsche Cup wheels 17 X 9 (\$125 ea) Two used S-02 tires 205/50ZR17 (\$40 ea) Two used S-02 tires 255/40ZR17 (\$40 ea) Porsche Motorsports lubrication mod kit for 996 (\$900) Brent 815-222-4631 or e-mail brent@midwest-aero.com [OND]

Parts New old stock, never used: BOSCH H1 headlights with Chrome trim rings. 55w/100w bulbs. Plus set of primered, trim rings for matching body color. Will fit up to '94 911 model year. \$350. HIRSCHMANN radio antenna, manual, black mast. \$30. Primered headlight retainer rings for regular headlights. \$50. Chet 773-702-3311 days 630-910-0597 evenings [OND]

Wheels/Tires 4 BMW Alloy wheels 15" x 7.5" with Goodyear 205/65/15 tires mounted. Wheels from 1994 525i. Mint condition. Spare included. Asking \$350.00 obo. Brain 630-469-5979 [SON]

PARTS - 95mm stock pistons, Carrera balanced rods for 3.2, 3.2 cams w/grind for mass flow, Auto Authority mass flow w/ Euro-brain box, Auto Authority mass flow chip, Andial twin-plug module for motronic, 3.2 Oil tank, 3.2 Bosch fuel pump, 3.2 distributor, 993Twin plug distributor, Spark plug wires for twin plug, Under fender thermostat, 3.2 starter, Complete set of 911 gauges, Steel turbo fenders, Iroc front spoiler (damaged), Light weight fiberglass hood, 15 gal fuel cell w/dual pick ups for 911, George, Days 708-331-8707 or gmueller@greatline.net [SON]

BOXSTER S HARDTOP - Arctic Silver - no rain, snow, smoke. Used 3 days then stored. Perfect condition, with OEM cover and felt piece for rear window. Easy pickup in Bloomington, Illinois. E-mail photos available. \$1350. Morgan - 309-747-4333 (raines@gridcom.net). [ASO]

WHEELS/TIRES - 2000 OEM 996, 17", 10-spoke, lightweight alloy wheels with Pirelli P-Zero Rossa tires (3000 easy street miles). Fits 996 and Boxsters. In perfect condition. Easy pickup in Bloomington, Illinois. \$1200. Morgan - 309-747-4333 (raines@gridcom.net). [ASO]

SIMPSON 5 1/2 POINT HARNESSSES - Never used. Black, pull-down, camlock. Made for Boxsters driver and passenger sides from Dave's Motorsports with all hardware and bolts. \$325 for both only. Morgan - 309-747-4333 (raines@gridcom.net). [ASO]

Misc

1867 Farm House and Barn, very pretty pond and trees. Has an extra lot to sell later in "Endless summer" home sites at GingerMan Raceway. All sites have direct access to the TRACK & RACE SHOP! Beaches, Boats, Sunsets, Golf, Motorsports, Tracksides Assistance and Nature all in your back yard. Farm House \$180000; Home sites \$65000 Free track time with all pur-

Wanted

chase and invitations to Special Events at GingerMan Raceway. Dan 269-253-2017 [OND]

Trailer Light-weight open trailer in good condition to haul my 911 to the track and back. Call Chick at 630-742-3333 or chick@theratechequip.com [OND]

You Can Help The Club!

Since the departure of Paul Silver, the Chicago Region has been without an official club photographer. What we need are some people with 35mm or digital cameras to help out.

Although asked to take this job, my schedule simply doesn't permit me to make it to all the events, so I was asked to take the role of head photographer.

I have see quite a few people taking pictures at a lot of the events this past year, and certainly there are plenty of nice shots out there of people enjoying themselves and our favorite car in all kinds of places.

Like any magazine, Scene relies on photos to go with articles to make them more appealing. Most people would agree that publications with pictures are more enjoyable, and then there's the idea that everyone wants to see their car in a magazine, or maybe of them and friends enjoying the moment. So, help us help you!

Being fairly active in the club has allowed me to participate in Driver's Ed, Concours, Rallye, the Potter's Picnic, the tech fair at Northstar Motorsports and so on, but there's plenty that I haven't attended. It doesn't matter if you attend a wide range of events, or mainly concentrate on your particular area of interest, it would be a big help to have more pictures from more sources. Besides, here's your big chance to get published.

Those that are interested can contact me for additional information via e-mail at Porsche575@comcast.net, or call at 630 759-2099.

Thanks in advance for your help from all of us at the club!

Russ Pesko

WE GO THE DISTANCE FOR SUPERIOR SERVICE

**VEHICLE MAINTENANCE & PERFORMANCE
AUDI BMW MERCEDES PORSCHE VW**

KELLY MOSS MOTOR SPORTS

★ ★ ★ ★ ★



**STREET CAR
MAINTENANCE**

**RACE CAR
PREPARATION**

**TRANSPORTATION
SERVICES**

**MODIFICATION &
BUILDING**

**PAINT &
COLLISION REPAIR**

VINYL GRAPHICS

CHECK OUT OUR WEBSITE AT:

www.kellymoss.com

**3017 PERRY STREET
MADISON, WI
53713
608.274.5054**



Imagine...

Your Own Private Autobahn!

Introducing the Autobahn Country Club in Joliet... designed to bring you the best of motorsport, leisure and entertainment facilities. The track and facilities of the Autobahn Country Club are being designed to cater to all forms of motorsports, and to provide members with a great environment for racing, touring, concourse and entertaining.

We've enlisted preeminent road course designer Alan Wilson to develop the Autobahn Country Club's Grand Prix track. Alan's work includes the South Carolina Motor Sports Park and the GingerMan Raceway in Michigan. Before becoming a full time motorsports facility designer, Mr. Wilson was a national level competitor in both car and motorcycle racing.

Track Features:

- 2.2 Mile Track | 11 Turns
- 1.7 Mile Track | 13 Turns
- 4 Mile Track | 22 Turns
- 1 Mile Shifter Kart



Visit our website...

www.autobahncountryclub.net

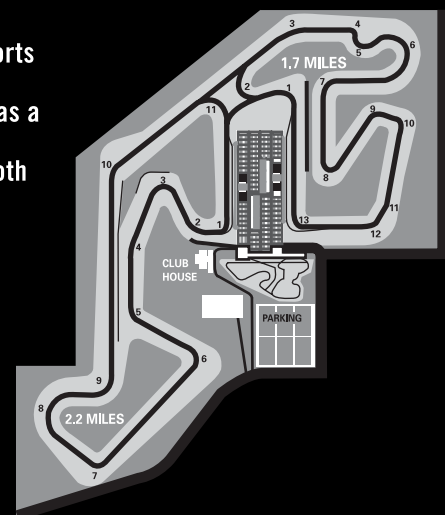



Steve's Tech Corner:

Bump Steer

by Steve Grosekemper,
San Diego Region (from
THE WINDBLOWN
WITNESS)

Steve Grosekemper is shop
foreman at Dieter's Porsche
and BMW Service in down-
town San Diego

Racer Lingo – Bump Steer

If you spend enough time at the various PCA events, you will eventually hear a multitude of new words that may not be in your daily vocabulary. These are words used by track and bench racers alike. They are best described as racer lingo, or Porschese.

You may hear words like apex, heel and toe, corner balance and bump steer. It is my goal to explain this sometimes-foreign tongue and convert it into plain English.

Bump steer is one of the few terms which is actually what it says

(unlike heel and toe). If you hit a bump, the car steers to one side. On early Porsches, such as 356s, the tie rod ends were of two very different lengths (see figure #1). They were installed in the car at an angle. When the car hit a bump and lowered, the short tie rod would straighten more than the long one. This would

increase the amount of toe the car would see on the short tie rod side, causing the car to steer to the right when it hit a bump.

Later on, when the 911 was introduced, this problem was addressed by using rack and pinion steering with equal length tie rods. In these cars the tie rods were parallel with the ground and caused very little toe change as the car went through bumps (see figure #2). As time went on, people discovered that if you lowered a 911 it would handle much better. However, this caused yet another problem: the tie rods were now at such an angle that a bump in the road would cause excessive toe change (see figure #3). While this problem would not cause the car to pull to one side or another, it did create a very darty feeling.

The cure was to install spacers between the steering rack and the front suspension member to raise the steering rack. This levels out the angled tie rods causing less toe change. This is what is done when someone is said to set the bump steer.

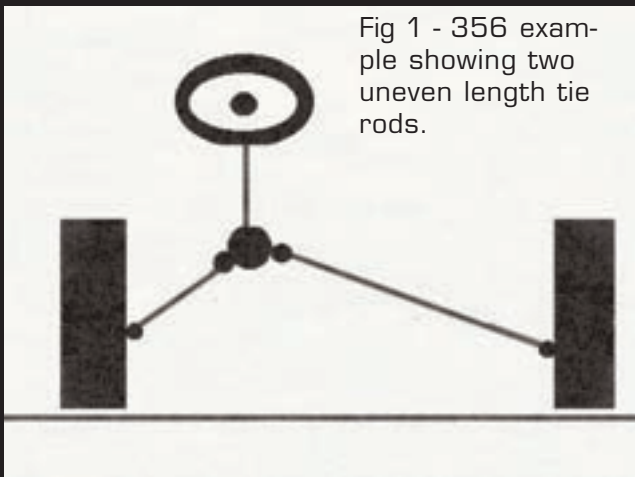

Fig 1 - 356 example showing two uneven length tie rods.

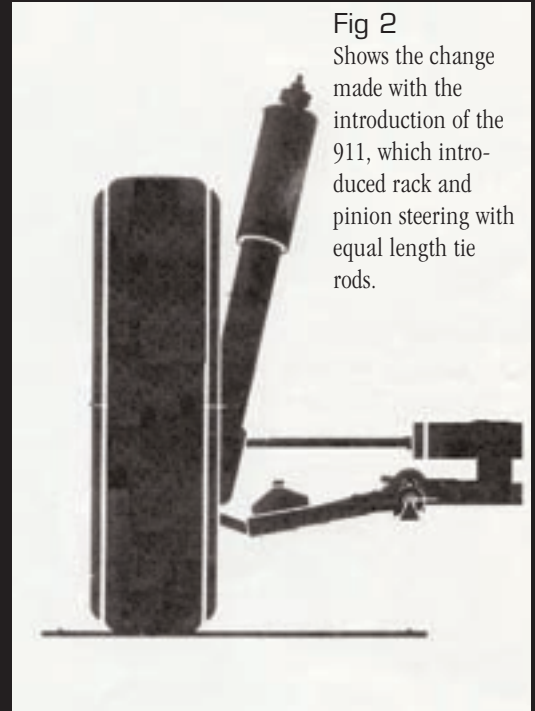

Fig 2 Shows the change made with the introduction of the 911, which introduced rack and pinion steering with equal length tie rods.

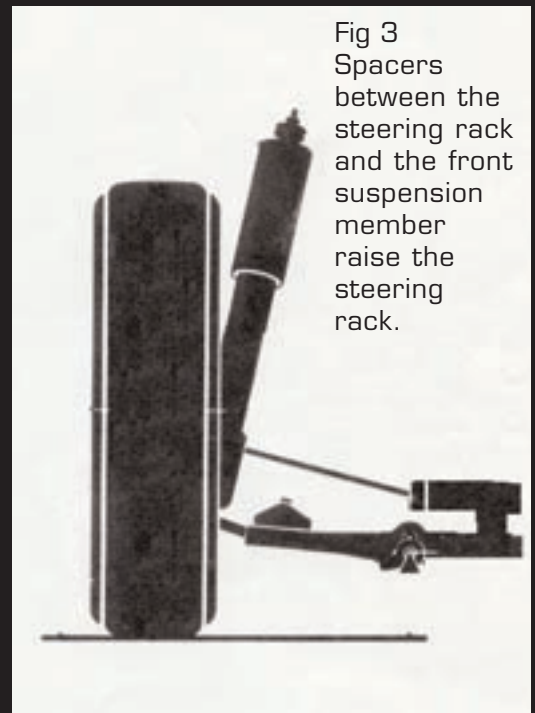

Fig 3 Spacers between the steering rack and the front suspension member raise the steering rack.

2003 Board of Directors



President
Keith Clark
 630-690-3381 h
 630-690-3394 f
 ClarkFNFlying@aol.com



Vice President
Jim Jacisin
 630-279-4835 h
 630-665-3491 f
 james@design-dept.com



Secretary
Mary Anne Nowakowski
 847-929-1831 w
 847-470-1204 f
 nowakowskim@permapipe.com



Treasurer
Jack Stephensen
 708-865-1465 v
 847-541-6171 f
 jstephensen@aol.com



Past President
Ed Barnicle
 630-323-2963 w
 630-323-5334 f
 ebarnicle@dolphincartage.com



Director
Pete Hackenson
 630-655-1629 h
 630-655-4841 f
 P.Hackenson@attbi.com



Director
Chris Inglot
 847-559-1126
 773-286-4811 f
 Cinglot@aol.com



Director
Ken Pesavento
 630-469-1546 v
 kenneth_a_pesavento
 @ml.com



Director
Shawn Young
 630-205-0055 c
 630-758-1108 f
 2DPD@attbi.com



Director
Chuck Bittman
 708-352-9505 h
 708-354-9505 f
 cbittman@bellebotanicals.com

2003 Coordinators

Advertising:	Susan Shire, 847-272-7764, 272-7764 fax, ChiScene@aol.com & Pat Yanahan
Autocross:	Mike Gallagher, 773-929-8109 v/f, 312-919-8109 c, foggy@21stcentury.net & Shawn Young
Autocross:	Shawn Young, 630-205-0055, 630-600-0054 fax, 2DPD@attbi.com
Archive Historian:	John O'Keefe, 708-531-9116
Charity:	Doug Coup, 847-429-0794, 847-429-0912 fax, douglascoup@msn.com
Chicago Scene:	Scott Adleman, 847-390-8666, 847-390-8885 fax, saa@preres.com
Chief Driving Instructor:	John Ruther, 847-304-5515, 847-304-5615 fax, john@northstarmotorsports.com
Concours:	Jim Jacisin, 630-279-4835 h, 630-665-3491 fax, james@design-dept.com & Pat Yanahan
DE – Blackhawk:	Dan Gallagher, 708-784-0784, 708-784-0785 fax, Bbabies@aol.com & Pete Hackenson, 630-655-1629, P.Hackenson@attbi.com
DE – Gingerman:	Jeff Girard, 630-985-6739, 630-985-6739 fax
DE – Road America:	Pete Hackenson, 630-655-1629, hotline 847-604-4795, 630-655-4841 fax, P.Hackenson@attbi.com & Keith Clark
DE – Tech:	Toby Duckett, 630-248-7680, toby@mc2fyi.com
Database:	Debby Leed, 847-382-6911, 847-382-3562 fax, leedlast@hotmail.com
Goodie Store:	Karen Hackenson, 630-655-1629, 630-655-4841 fax, P.Hackenson@attbi.com
Insurance:	Keith Clark, 630-690-3381, 630-690-3394 fax, ClarkFNFlying@aol.com
Membership:	Van Miller, 847-949-0972, Quik550@aol.com
Novice Driving Instructor:	Ed Leed, 847-382-6911, 847-382-3562 fax, leedlast@hotmail.com
Photographer:	Paul Silver, 847-634-6587 h, paul-silver@attbi.com
Property:	Ed Leed, 847-382-6911, 847-382-3562 fax, leedlast@hotmail.com
Publicity:	Susan Shire, 847-674-2285, 847-679-8973 fax, chiscene@aol.com
Race Tech:	Todd Conforti, 847-952-0070, 847-952-1261 fax, TLControls@aol.com
Rallye:	Tom & Phyllis Harwood, 847-742-6804, 847-508-3726 cell, trh911sc@aol.com
Rallye:	Ken Pesavento, 630-469-1546 v, kenneth_a_pesavento@ml.com
Safety:	Todd Conforti, 847-382-9653, 847-952.1261 fax, TICcontrols@aol.com
Social:	Nikki Pesavento, 630-469-1546, npesavento@rwbaird.com
TRAC 2003 Race:	Pete Hackenson, 630-655-1629, hotline 847-604-4795, 630-655-4841 fax, P.Hackenson@attbi.com & Keith Clark
Webmaster:	Greg Gulik, 312-642-5377, webmaster@pca-chicago.org

Why Would You Ever Consider A Luxurious PreOwned Vehicle From
Napleton Porsche in Westmont?

The Answer Is Quite Simple...



***It's All About
Selection.***

***The Midwest's Largest Exclusive Porsche Dealer
Finest Selection Of New And Preowned Porsches In The Midwest!***



NAPLETON
PORSCHE

201 E. Ogden Ave. • Westmont, IL • 630-725-0911 • www.ednapleton-porsche.com



HOT, FRESH AND... FAST



2204 N Lincoln Ave.
Chicago, IL
(773) 472-7400

36 S La Grange Rd.
La Grange, IL
(708) 352-8882

15256 S. La Grange Rd
Orland Park, IL
(708) 403-3535

118 S Clinton St.
Chicago, IL
(312) 876-1188

1504 N Naper Blvd.
Naperville, IL
(630) 505-0600

75 E Wacker Dr.
Chicago, IL.
(312) 263-0070

CHICAGO SCENE

959 Lee Street
DesPlaines IL 60016-6545