

SUPPLEMENT TO 911 WORKSHOP MANUAL

(XIV)

The supplement contains pages

Index to Group "B"

B 1 - B 103

(Existing pages of Group "B" should be deleted.)

In addition:

2nd register for supplements to
Workshop Manual 911

We would ask you to file this supplement in the usual way under Group "B" in the 911 Workshop Manual.

We would also ask you to file the second register for supplements.

Printed in Germany

Dr. Ing. h. c. F. Porsche KG

October 1968

INDEX

GROUP B: BODY

Body design details B 1

DOORS AND WINDOWS

Preliminary operations:

1 BO Removing and stripping damaged door B 5
2 BO Fitting door shell B 7
3 BO Assembling complete door B 14
4 BO Removing and reinstalling vent window B 18
5 BO Removing and reinstalling windshield B 19
6 BO Removing and reinstalling rear window B 21
7 BO Removing and reinstalling rear vent window B 22
8 BO Removing and reinstalling Targa rear window B 23
9 BO Removing and reinstalling Targa top rear section
and renewing zipper B 25

FRONT FENDER

Preliminary operations:

10 BO Removing and reinstalling front fender B 28

BUMPERS

Preliminary operations:

11 BO Detaching and fitting front bumper B 30
12 BO Detaching and fitting rear bumpers B 31

LIDS

Preliminary operations:

13 BO Removing and reinstalling front lid B 32
14 BO Removing and reinstalling rear lid B 34

ELECTRICALLY OPERATED SLIDING ROOF

Preliminary operations:

15 BO Removing and reinstalling sliding roof B 36
16 BO Renewing guide rails, guides with sliding roof removed B 39
17 BO Renewing electric motor with gear B 40
18 BO Relining top frame B 40

BODY INTERIOR

General	B 41
Preliminary operations:	
19 BO Removing and reinstalling front seat	B 42
20 BO Renewing reclining seat bracket	B 43
21 BO Installing headrest - special option	B 44
22 BO Removing and installing occasional seat backrest	B 44
23 BO Removing and reinstalling roof lining	B 45
24 BO Carpets, side paneling and front compartment mats	B 46
25 BO Dashboard paneling	B 47

TRIM STRIPS

Preliminary operations:	
26 BO Front bumper trim strip	B 49
27 BO Installing front grilles	B 51
28 BO Installing air intake grille	B 51
29 BO Trim strip under door	B 52

VENTILATION

Preliminary operations:	
30 BO Removing and reinstalling ventilation system	B 53

REPAIRS AND CHECKING

BODY SHOP EQUIPMENT

General workshop equipment and tools	B 55
Special tools	B 55
Self-constructed gauges	B 56
Check dimensions - front section	B 89
Check dimensions - rear section type 912	B 91
Check dimensions for Targa repair instructions	B 93
Check dimensions - Coupé interior paneling	B 95
Check dimensions for Coupé repair instructions	B 97
Preliminary operations:	
31 BO Checking body on the Celette rig	B 58
32 BO Renewing body front section - Coupé	B 59
33 BO Body front section with hinge pillars, instrument panel and screen frame	B 63
34 BO Renewing partition wall	B 64
35 BO Renewing door sill and side member	B 66
36 BO Renewing rear fender	B 69

37 BO	Partially renewing fender I	B	71
38 BO	Partially renewing fender II	B	72
39 BO	Renewing rear axle transverse tube	B	74
40 BO	Instructions for rear end repairs	B	77
41 BO	Renewing roof with roof frame and sliding roof	B	79
42 BO	Adjustment and sealing operations on Targa roof	B	83
43 BO	Conversion from Targa top rear section to Targa rear window	B	86

PAINTWORK

General	B	99
Work bays and special instructions	B	99
Repainting	B	100
Color range and color coding	B	102

BODY DESIGN DETAILS

General

The body is all-steel construction.

All pillars and frame members are of thin wall sheet metal and have been deep-drawn for maximum strength, and also to enable all control cables, linkages, heater lines and cables to be accommodated in the spaces so formed.

The outer skin extending from the windshield pillar to the tail end is welded to the floor group, the wheel arches and pillars to form a rigid integral construction unit.

The aerodynamic contours of the body offer very low wind resistance.

Doors

The doors are fixed to the front pillars of the body by means of internally fitted hinges. They are opened from outside by means of a pushbutton located in the door handle which can be locked with the ignition key.

From inside the doors can be locked by pushbuttons. Opening of the doors from inside is effected by pushing a button on the front of the armrest.

Opening of the doors is limited by a strap which at the same time holds the door in the open position. It has been made possible by means of adjustable hinges and striker plates for the exterior contours of the door to be lined up exactly with the adjacent body contours.

Windows

The curved door window glass, vent windows and hinged rear side windows are of single-layer safety glass. The door windows can be raised and lowered by means of crank gear. Integral metal frames with fitted velvet sections ensure silent window operation.

The opening of the vent and rear side windows can be set according to the degree of ventilation desired. The catches can only be opened and closed from the car interior.

For reasons of safety high-grade laminated safety glass has been used for the windshield. It locates in a flexible rubber molding surround which compensates for slight variations between the shape of the windshield and the windshield opening.

The rear window glass (the remaining glass) is of single-layer safety glass. Fitment and location as for the windshield glass.

Front fenders

The front fenders are bolted on. The filler neck for the fuel tank is located in the left-hand front fender.

Bumpers

The bumpers fitted front and rear are detachable. They are cellulosed in the same color as the car and have trim strips with rubber or plastic inserts.

The bumper overriders are chromium plated.

Lids

The front and rear lids have internally fitted hinges. The lid catches can only be opened from the car interior by means of cable pulls. If the cable shears the catch opens automatically. For safety reasons however the front lid can only be opened after an additionally fitted safety catch has been disengaged by hand.

Built-in pneumatic springs retain the open lids in any desired position.

Under the front lid is located the trunk compartment with the toolkit, the spare wheel, the battery and the fusebox.

The rear lid covers the engine compartment and carries the air intake grille for the engine.

Seats

Both front seats are mounted on slide rails and are adjustable backward and forward. The seat backs can be set in stages by means of the reclining seat mechanism for any position down to horizontal.

The seat back of the front passenger seat has an additional catch and can only be folded forward when this catch has been disengaged.

Trunk compartment

Luggage space is provided by the front compartment under the front lid. The spare wheel, the toolkit, the battery and the fusebox are also located here.

Additional luggage space can be made in the back of the driving compartment if the seat backs of the occasional seats are folded forward.

Interior fittings

Padded leather cloth in various colors and patterns has been used for the upholstery of the instrument board paneling, the door panels, the rear side panels and the rear paneling. The leather cloth used for the roof lining is perforated.

The side panels in the front foot compartment, the tunnel, the side members and the occasional seat recess in the rear acting as a cross member, together with the trunk compartment are carpeted.

The floor is covered with rubber mats or carpets according to vehicle type.

For sound proofing and insulation all hollow components are sprayed or painted with rust inhibitor before welding.

All surfaces which are not cellulosed in the body color, in particular the floor group with the wheel arch panels and the interior compartment are sprayed with an efficient anti-drum compound which at the same time provides rust protection.

For further sound proofing the interior compartment together with the front and rear compartments are covered on special instructions with bitumen board, bitumen felt, jute felt and cork felt mats.

For heating purposes the hot air from the engine fan is blown through heater ducts into the car interior, to the windshield and on the coupé also onto the windshield glass. The hot air volume can be controlled by means of a hand lever on the tunnel and by slides on the side members in the front foot compartment.

For fresh air ventilation air intake slots have been provided in the windshield pillar in front of the windshield glass. An air scoop conducts away any water and passes the fresh air through a louver into the car interior onto the center of the windshield.

A proportion of the fresh air is diverted by the air scoop through connecting hoses and passed through the side heater louvers onto the windshield glass. The fresh air flow can be regulated by means of a lever on the instrument panel.

By switching on the heater the incoming fresh air can be mixed with hot air.

DOORS

Special tools:

P 290 Extractor for door hinge pins

(Made up tools)

P 1000 Door flange gauge

P 1001 Door gap gauge

P 1003 Hinge adjusting plate

Note!

It is recommended that repair of accident damage should start with the fitting of the doors.

REMOVING AND STRIPPING DAMAGED DOOR

1 B0

1. Unscrew trim strip and button on door catch.
2. Remove cover from window crank, screw bolt out of crank and remove crank with bezel.
3. Unscrew armrest covering. Disengage door interior catch, Undo 3 bolts on the bottom of the armrest and remove armrest.
4. Unscrew door panel, pull off door panel with clips and remove.
5. Remove window glass well cover strip.
6. Undo door strap.



Fig. 1



Fig. 2

7. Release door window frame and extract.



Fig. 3

8. Disengage door window glass and remove.

9. Remove crank gear.

10. Unscrew door exterior handle.



Fig. 4

11. Remove door lock with remote control.

12. Remove hinge pin with special tool P 290 and remove doors.



Fig. 5

1. Screw door shell onto hinge pillar. At first only screw up loosely one of each of the three screws per hinge. Final adjustment will be carried out lining up with the front fender.
2. Adjust door height and door gap. The exterior contour of the door must line up perfectly with the treadplate, the front fender and the rear fender.
The door can be moved outwards on the hinge side with the aid of special tool P 1003.

Here it should be checked whether an additional packing piece is necessary for the striker plate. The door gap should be 3 - 4 mm (0.12-0.16") at the bottom, the front and the rear. At the top the front door gap should be a maximum of 4 mm (0.16") from the windshield pillar.

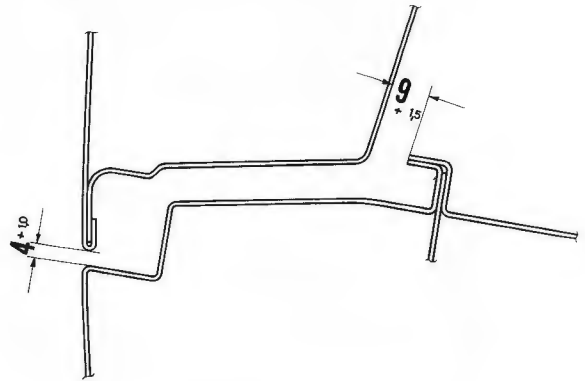

Fig. 7



Fig. 6

Adjustment inwards should be carried out by tapping the hinge portion on the inside of the door with the door removed. On the door catch side adjustment is carried out by means of the striker plate.



Fig. 8

Adjustment of the door gaps in a forward direction can be effected by tapping the hinge eye with a suitable piece of hardwood.



Fig. 9



Fig. 10

The opposite effect is achieved by using packing piece no. 901, 531, 945, 20. At the same time it should be ensured that the recommended distance from door to hinge and lock pillars as well as to tread plate is maintained.

Alignment of both hinge axes should be checked with a straight edge.



Fig. 11

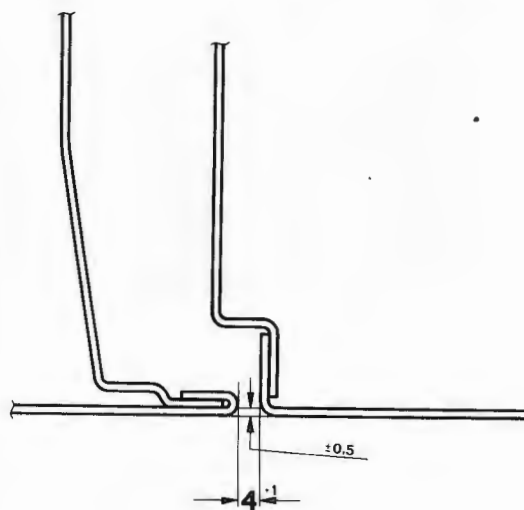

Fig. 12

3. When fitting the door lock it should be noted that there are various designs of lock. If an old-type lock is locked with the pushbutton on the inside of the door and at the same time the lock cylinder on the exterior door handle is pressed then the lock mechanism can jam. We recommend therefore that the new model lock should be fitted.



Fig. 13

- b. It should be ensured that the longer pressure pin part no. 901, 531, 919, 20 (left)
901, 531, 920, 20 (right)
does not touch the lock pressure plate when disengaged. If this is not done there is the risk that as a result of heavy vibrations on bad roads the catch can disengage and the door spring open.



Fig. 15

Here the following should be noted:

- a. On the new lock the pressure plate which is operated by the exterior door pushbutton is located on a continuous spindle. The pressure plate has a more pronounced angle and increases the distance from the pressure pin of the door exterior handle. For this reason it is necessary to change the operating peg with the longer pressure pin.

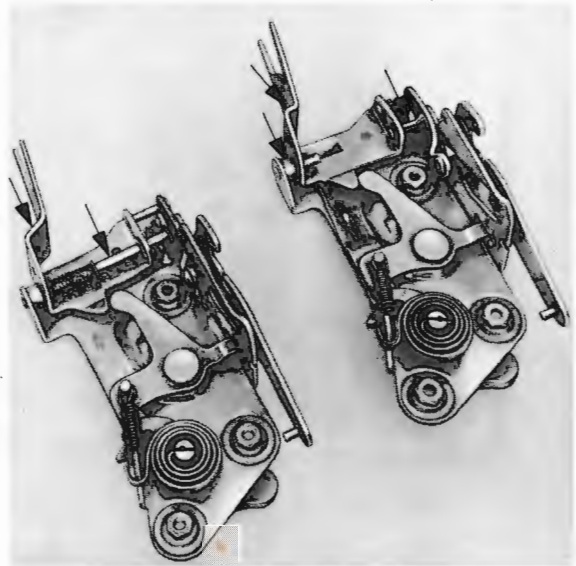

Fig. 14



Fig. 16

- c. As a further safeguard against the door springing open the shape of the lock peg on the door lock and simultaneously the shape of the striker plate have been altered so that the lock peg is additionally supported in the striker plate. The hole for the lock peg should be enlarged to approx. 33 mm (1.3").

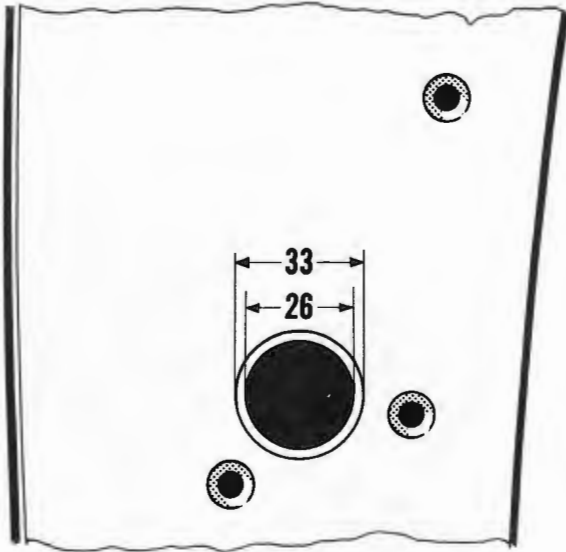

Fig. 17

- d. A new type striker plate must always be fitted with a new type lock. Outer edge vertical - if necessary enlarge operating holes in lock pillar.

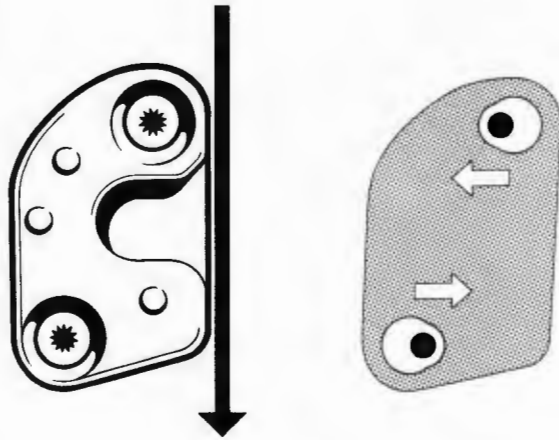

Fig. 18



Fig. 19



Fig. 20

Various lock positions

Doors closed - engaging the lock
Exterior door pushbutton - operation
Lock in normal position



Fig. 21

Opening lock - operation



Fig. 23

Doors closed - disengaging lock
Exterior door pushbutton - operation



Fig. 22

Lock open - normal position



Fig. 24

e. Old type: the two doors can only be locked from inside in the closed position.

New type: if the right-hand door is locked when getting out it will remain locked after closing and can only be opened from outside if it is unlocked from outside with the door key or from inside by means of the pushbutton. This lock operation applies to vehicles with left-hand drive and will be the reverse with right-hand drive vehicles.

f. Secure remote control for interior door push-button and catch to lock before fitting lock.

4. As regards the door weather strip the necessary contact pressure on the molding strip will be achieved if the clearance from the top edge of the sealing flange to the inside of the door is 9 mm (0,35").



Fig. 25

Check sealing flange with gauge P 1000 and if necessary align flange. On the first vehicles of the 911 type a tubular rubber molding was used for door sealing.

In addition as a temporary measure a foam rubber molding of larger section was fitted. For both sections a gap of 12 mm (0,47") from top edge of sealing flange to inside of door was necessary.

When changing these door seals to the new design the gap should be reduced from 12 mm (0,47") to 9 mm (0,35").

It is recommended when adjusting the door shell that the door window frame should be fitted temporarily so that the distance from the top edge of the sealing flange to the door window frame can also be adjusted to 9 mm (0,35"). Here it should be noted that this clearance should be reduced from 9 mm (0,35") to 6 or 7 mm (0,23 or 0,27") for a length of approx. 300 mm (11,8") in the region between the screen pillar and the roof, to ensure that higher contact pressure is obtained at this point and the window will not flutter at high speed.

At the same time it should be ensured that the recommended clearance between window frame and screen pillar and roof frame to lock pillar are observed.



Fig. 26

Note 1

5. The door shell has not been welded at the points indicated in the illustration. It is thus possible to twist the door when fitting. When the door fits these points must be welded. In addition a cover plate must be cut to size for the door window frame and then welded on the top edge of the door front and rear and solder filled to give a clean finish.

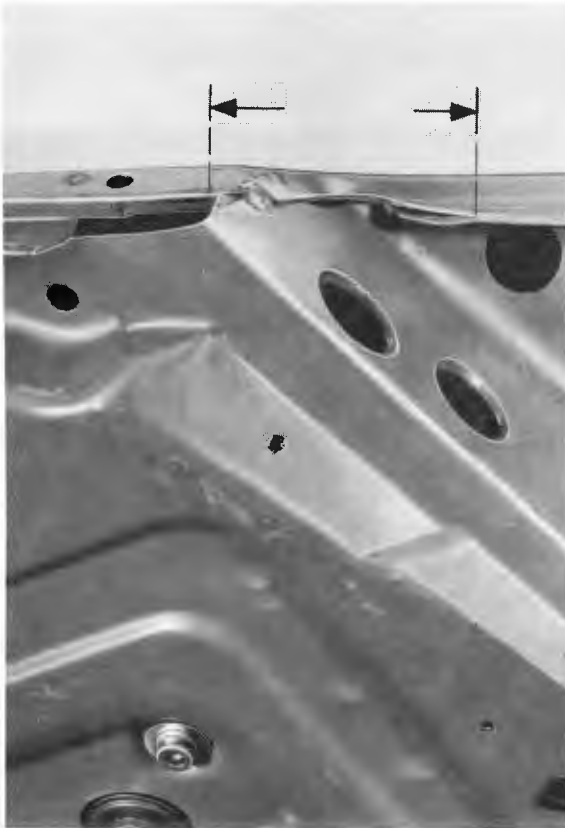

Fig. 27

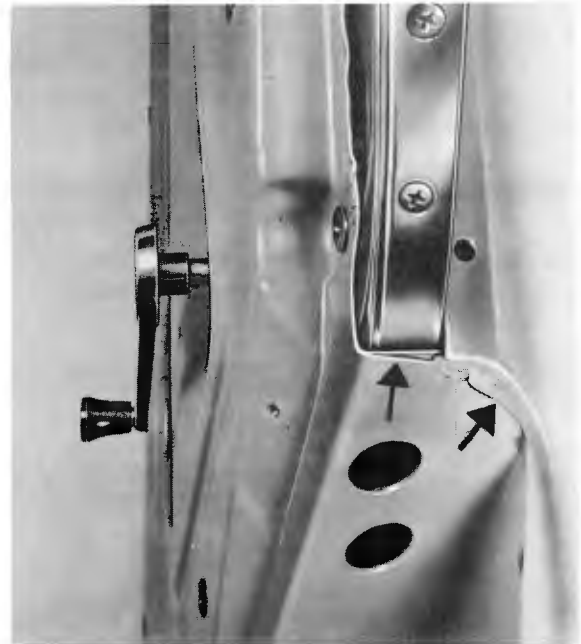

Fig. 28

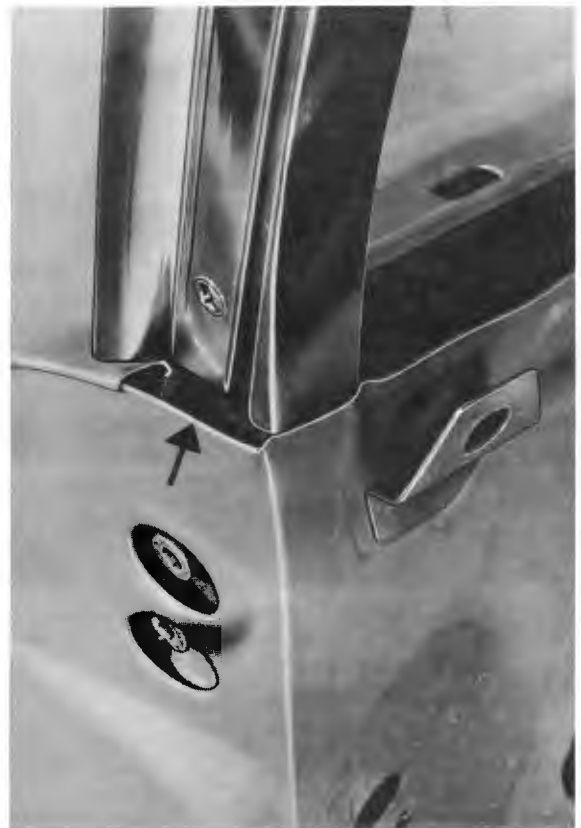

Fig. 29

1. Fit door check strap.
2. Fit door lock with remote control and catch.
3. Insert crank gear and screw up loosely with 4 socket head screws. Don't forget washers and spring washer!
Note!
There are three different crank gears:



Fig. 30

- a. Type with metal rollers and short fixing plate.
- b. Type with plastic slide and short fixing plate.
- c. Type with plastic slide and long fixing plate.

For repairs we recommend that only crank gears of the new types "b" or "c" should be fitted with the appropriate raiser bar, because type "a" is prone to rattling.

4. Fit window glass.
Set crank gear to half-way position and push door window glass with raiser bar fixed in position backwards onto the slide pieces of the crank gear from the front.



Fig. 31

5. To fit the door window frame crank the door window glass to half-way position and push the window frame into the door from above. The glass will slide in the velvet/rubber molding of the window frame. Adjust window frame and screw in position in the sequence shown in Fig. 32.

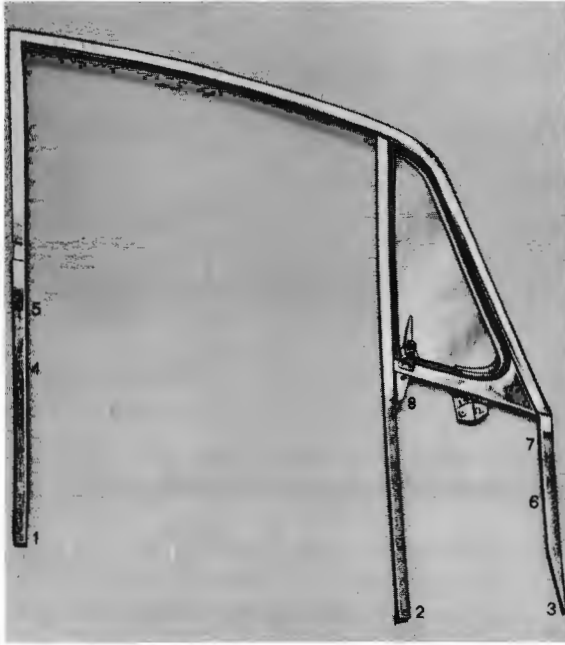

Fig. 32



Fig. 33

Ensure that the fixing screws are not too long and therefore press on the window guide molding.



Fig. 34

6. Crank door glass up and adjust. Tighten fixing bolts of crank gear.



Fig. 35

7. Fit exterior door handle.
8. Secure window well bar together with packing and clips (push in rubber moulding first).
9. Grease door lock and crank gear and check.
10. Glue in stop pad on crank gear.

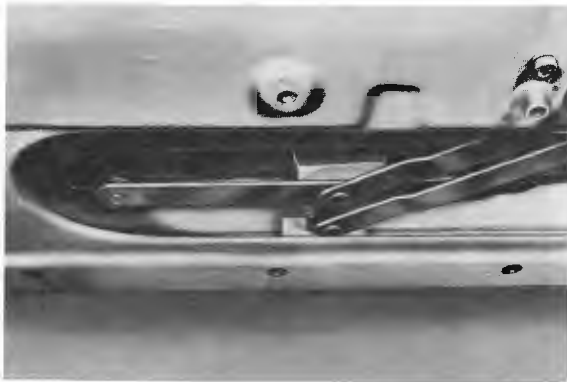

Fig. 36

11. For crank gear type "a" only.
To avoid rattling between raiser bar and crank gear a foam rubber strip of dimensions 50x50x8 mm (1.10 x 1.10 x 0.31") should be glued onto the raiser bar.
12. Stick felt packing pieces 6 mm (0.23") thick onto the door interior plate under the remote control rods.
13. Fit door weather strip.
Terokal No. 2444 is recommended as adhesive for this purpose. The door seal should be checked with a strip of paper wedged between the inside edge of the door and the weather strip. If the strip of paper can be pulled out quite easily the contact pressure is insufficient and the weather strip should be packed out from underneath at the place concerned with thin strips of foam rubber.
This test must be carried out right round the door including the window frame. If necessary check that the window frame is secure in the door.

14. All fitting holes in the door inner plate should be sealed over with leather cloth or plastic sheet to ensure water tightness.



Fig. 37

15. Fix door panel on door frame with clips (push in rubber grommets beforehand).
16. Additional securing of door panels with screws. With old design ensure that the door pockets are secured against tearing at both ends with a screw.
17. Fitting the armrests:
 - a. Place armrest vertically and secure at the back with cylindrical head screw.



Fig. 38

- b. Pivot armrest forwards into horizontal position and secure with two further cylindrical head bolts.
- c. Secure handle with two screws below trim strip. (No handle on driver's side.)
- d. Insert pushbutton for lock remote control backwards into the armrest and push on the nipple. The button must move freely; if this is not the case bend control rod.
- e. Secure cover cap on bottom of armrest with two bolts.
- f. With new design door pocket swing upwards and secure at sides with two screws.



Fig. 39

- 18. Secure trim strip onto which velvet strip has already been fixed on door frame. At the rear with snap nut and self-tapping screw at the front with self-tapping screw only.
- 19. Screw on knob for door catch.

- 20. Fit window crank with bezel. With the window closed the window crank should point diagonally downwards parallel to the window frame.
- 21. All holes in window frame should be sealed with rubber plugs.
- 22. Check door for proper location. Make final adjustment to striker plate in relation to door lock and position of lock peg.



Fig. 40



Fig. 41

Removing

1. Unscrew trim strip and pushbutton.
2. Remove window crank and disengage door panel at the front until access can be gained to the hole for the vent window fixing.
3. Slacken vent window friction catch through opening in door interior plate.



Fig. 42

4. Extract sealing strip frame by top pivot.
5. Unscrew top pivot by inserting 7 mm (0.27") open ended spanner into well of window frame.
6. Extract vent window upwards if necessary further loosening friction catch. With the frames of the initial design there are spacing washers on the peg. Care should be taken that these do not drop into the door frame when removing.

Reinstalling

1. If necessary renew sealing strip frame on vent window.
2. Insert peg of vent window through sealing strip frame into the vent window friction catch, tighten the latter slightly.
3. Fit top pivot and secure in well of window frame with washer. Tighten spring of vent window friction catch as required.



Fig. 43

4. Push sealing strip frame carefully into window frame checking that it seals properly all round.
5. Seal over fitting hole. Secure door panel with window crank, fit trim strip and pushbutton.

Removing

1. Fold wiper arms forward.



Fig. 44

2. Cut through the rubber seal along the outside edge of the bezel with a knife working along the windshield cutout.



Fig. 45

3. Extract bezel from the rubber with a suitable scraper blade. Cut through the rubber parallel to the windshield, so that the windshield glass can be extracted forwards and the remainder of the rubber seal can be pulled out.



Fig. 46

Reinstalling

1. Thoroughly remove all remnants from windshield recess.
2. Fit check template and check for proper seating, if necessary rectify.

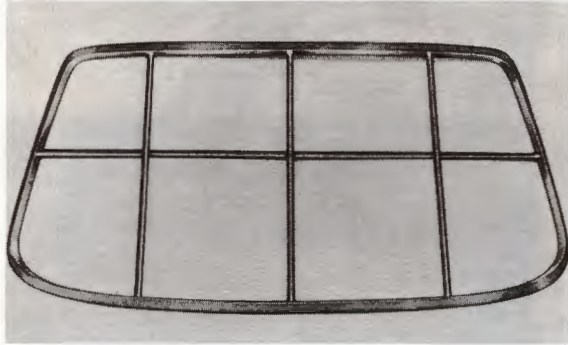

Fig. 47

Note!

3. Only a new rubber molding should be fitted to the windshield.
4. Smear bezel groove with wet soap to facilitate installation.
5. Insert bezel starting at bottom center. There should be approx. 1 cm (0.39") clearance top and bottom between the two halves.



Fig. 48

6. Place windshield glass on outside and draw a piece of string into the rubber molding starting at the top so that the string overlaps about 30 cm (11.8") in the top molding.

7. To make it more slippery smear with glycerine the lip of the rubber molding which is pulled inwards over the upright rim.
8. Insert windshield glass at the bottom so that the distance from the frame is uniform.
9. Slowly pull out the string parallel to the windshield tapping the windshield from outside with the palm of the hand. Ensure that the lip of the rubber molding slides over the vertical rim properly. In so doing pull in both sides in turn down to the bottom outside corner to avoid excessive stress and shifting of the windshield.



Fig. 49

10. Tap round windshield once again. Push slide pieces over both bezels until central.



Fig. 50

11. Line up bezel with scraper blade or a piece of wood and a light hammer so that the distance from the windshield cutout is uniform all round.



Fig. 51

12. Lift the rubber moulding first of all away from the metal and then away from the glass with a scraper blade and seal with special cement.



Fig. 52

13. Remove excess sealing compound with benzine.

14. Clean windshield and check for leaks.

REMOVING AND REINSTALLING REAR WINDOW

6 80

Removal and reinstalling of the rear window is carried out in exactly the same way as with the windshield.



Fig. 53

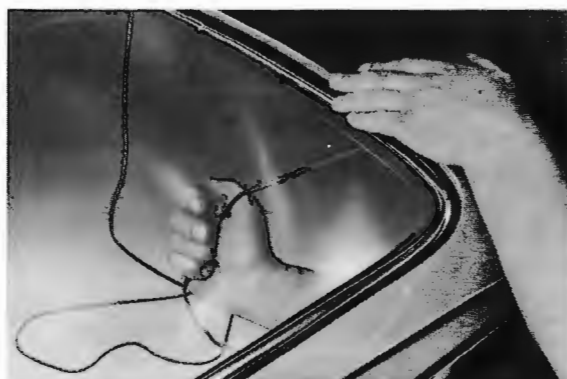

Fig. 54

Removing

1. Unscrew bolts on lock pillar.
2. Remove self-tapping screws of window catch from roof frame.
3. Push vent window forwards and outwards with the palm of the hand.
4. Unscrew chrome trim strip either from above (self-tapping screws) or under the fender (self-tapping nuts).

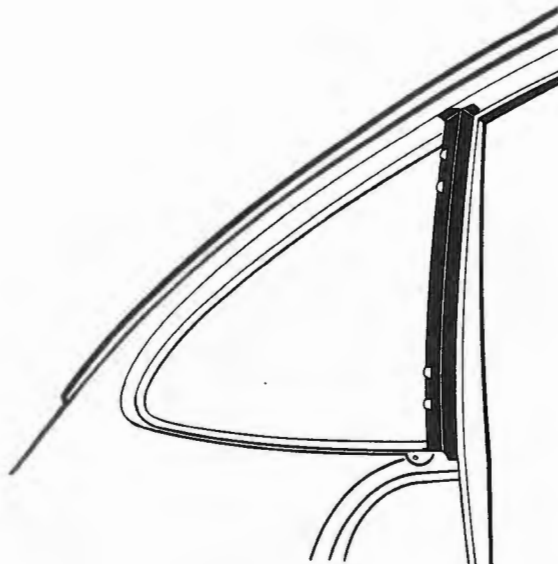

Fig. 56



Fig. 55

Reinstalling

1. Cut rubber strips to size as shown in sketch and attach with adhesive. Fit sealing strips to rim of lock pillar and roof frame.
2. Place underlay of Terostat strip under chrome trim strip and fit.
3. Insert rear vent window, pushing the perforated metal tabs on the vent window in behind the retaining lips in the lock pillar.
4. Screw up vent window at the front taking care to ensure equal distance between roof and fender.
5. Fix window catch to roof frame. The rubber seal in the chrome bezel must form a satisfactory fit and seal all round.



Fig. 57

Removing

1. Remove folding top.
2. Unscrew trunk clips and rear paneling.



Fig. 58

3. Remove left- and right-hand rear compartment trim strips.
4. Unscrew rear panel top section.
5. Remove interior lights, disconnect cable.
6. Undo safety bar inside covering and remove to the rear.



Fig. 59

7. Undo front seal frame along safety bar.
8. Remove self-tapping screws on chrome cover plate.
9. Unscrew chrome cover plate underneath fender and remove. Pull off rear seal.
10. With heated rear window disconnect cables in engine compartment and remove glass.

Installing

1. Fit check template, rectify window cutout where necessary.

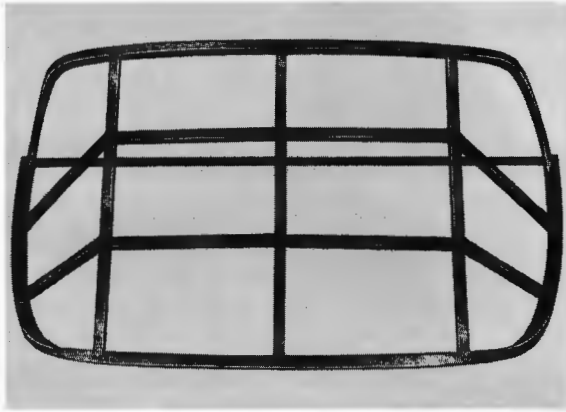

Fig. 60

2. Pull new rubber sealing strip onto glass and push in chrome bezel.
3. Check heater wires for function.
4. Pull two cords into rubber sealing strip.
5. Place glass in position and center exactly. Pull out front cord on both sides approx. 20 cm (7.9") then pull bottom cord out completely, pressing on glass with palm of hand and pulling out cord along safety bar.



Fig. 61



Fig. 62

6. Pull sealing lips over rim at the corners.
7. Fully seal glass and clean.



Fig. 63

8. Connect electrically.
9. Place chrome cover plate in position and screw up.
10. Cement sealing strips at front and rear of chrome cover plate.
11. Fit inside covering on safety bar, insert interior lights.
12. Insert rear panel top section, rear compartment trim strips and rear paneling.
13. Reinstall folding top and check for leaks.

Removing

1. Unscrew trim strips.



Fig. 64

2. Unscrew rear paneling and trunk clips. Use a small screwdriver or one with a flexible shaft for undoing the screws.



Fig. 65

3. Detach interior lights unscrew safety bar inside covering and remove to the rear.



Fig. 66

4. Undo securing screw with eccentric washer on tension arm so that the zippers can be fully opened.



Fig. 67

5. Unscrew the screws from the three eye bolts at the rear of the rear end bar, also the left- and right-hand fixing bolts for rear end bar and clamping bracket.
6. Detach top rear section. For this purpose push clamp bracket down and then pull first the top and then the bottom out from the roof bar.



Fig. 68

7. Unscrew lock sleeves of top catches from clamp bracket and screw the three eye bolts out of the rear end bar.



Fig. 69

8. Pull the left- and right-hand halves of the rear end bar as well as the clamp bracket out of the top rear section.



Fig. 70

9. Remove damaged zipper from top rear section.

Installation

1. Stitch the new zipper part no. 901.565.615.40 with a sewing machine onto the curved inside with large open stitches.
2. Cement zipper in position. For this purpose gather the threads on the insides of the curves and snip the outside accordingly so that the zipper locates snugly and no folds occur on the rear window.
3. Push in halves of rear end bar, ensuring that they are inserted on the correct sides, push in clamp bracket and secure the two lock sleeves.
4. Place top rear section in position with zipper open, loosely screw clamp bracket and rear end bar onto bottom of safety bar with spacer bush, washer and spring washer.
5. Smear sealing strip on safety bar and top of top cover with glycerine. Then tap in clamp bracket with padded wood.

6. Adjust and secure eye bolts on rear end bar so that the rear end bar seats evenly all round. Tighten bolts on left- and right-hand sides of safety bar.
7. Close top catches and install securing bolts with eccentric washer of tension arm.
8. Check zipper and close.
9. Install rear paneling, inside covering with lights and trim strips.

10. Clean top rear section.

Note: If the rear window has become clouded it should be cleaned with a good cellulose polish such as Herco 66 Kristall polish.

If the rear window is shattered the whole top rear section, part number 901.565.085.40 must be renewed.



Special tools:

P 1001 Gauge for door and lid gap
(own manufacture)

Removal

1. Remove fender bolt along wheel arch, door sealing plate and windshield pillar.
2. Remove headlamps, grille and light box.



Fig. 71

3. Remove grommet and tube for cable harness, withdraw cable harness, undo bolt on bumper.
4. Remove fender.
5. Additionally on left-hand fender disconnect and remove cable to filler cap.
6. Heat dowel pins on wheel arch and knock out.



Fig. 72

Fitting

1. Fit filler cap on left-hand fender.
2. Insert spring nuts in fender.
3. Offer up fender and screw up lightly. The beading along the top edge of the fender will only be installed during final fitting. For this reason the gap between the upper edge and the doors will at first be 1 mm (0.04") greater.
4. Line up fender connecting plate so that the door gap is 4 mm (0.16"). At the same time adjust alignment to door. If necessary elongate bolt holes.

5. The distance from the wheel arch to the top edge of the fender is 17 mm (0.67"). The wheel arch panel should be aligned so that the gap between fender and lid is 3 mm (0.12").

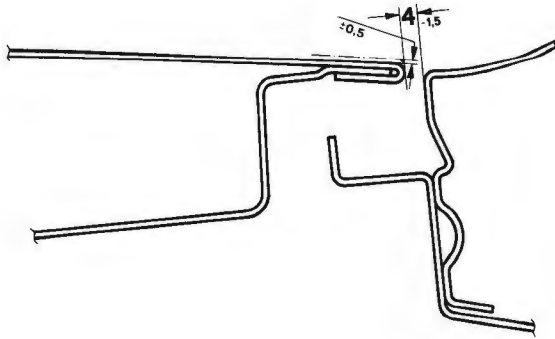

Fig. 73

6. Tighten fender bolts.

Fixing

1. When the fender has been fitted two 5 mm (0.19") diameter pilot holes should be drilled through wheel arch panel and fender and secured with steel rivets which should be hard-soldered with the head on the wheel arch panel.



Fig. 74

2. Fit bumper bar.
3. On older vehicles the grille was fixed in position by means of 4 screws; in this case small metal corners must be welded on the corresponding corners on the light box.

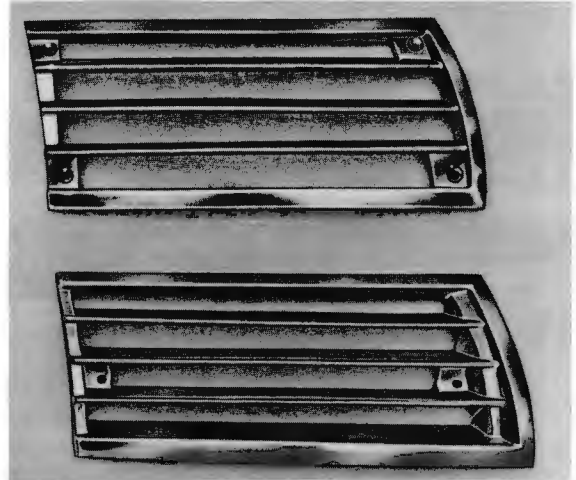

Fig. 75

4. Unbolt fender and cellulose.

Installation

1. Before final installation with the left-hand fender insert tube for filler cap cable. Pack wheel arch panel and fender joint plate with Terostat strip.
2. Place packing under bolts and tighten in the sequence shown in the illustration.
3. Fit electric cables, pull cables through. Fit headlamp and light box.
4. Cement sealing rubber for front lid in position.

Detaching

1. Jack up vehicle.
2. Undo screw connection with fenders.



Fig. 76

3. Unbolt spring bracket on wheel arch. If necessary disconnect cables on foglamps and driving lights.
4. Remove bumper forwards and strip if required.

Fitting

1. Secure sealing strip of front bumper on cross panel, cement projections onto fender bottom edges, check for seal with wheel cutout. When fitting push bumpers against the sealing strip.

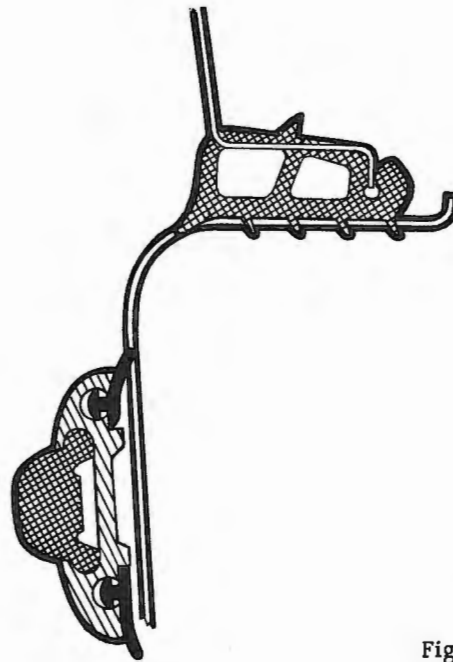

Fig. 77

Installing

1. Install trim strip and bumper overrides. On the 6-cylinder models secure bumper reinforcements with Epoxy resin. Place rubber packing pieces at both ends of reinforcements. Install spring bracket, and adjust so that the bumper lines up exactly with the fenders and does not project on either side.

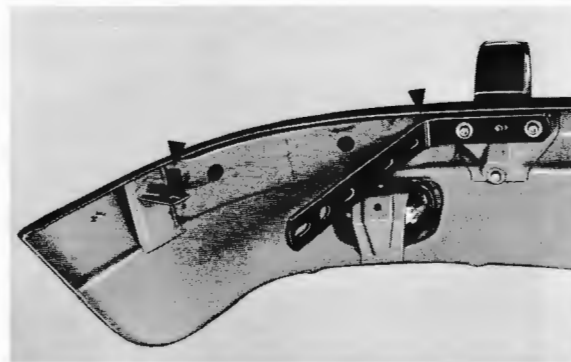

Fig. 78

2. Install fog lamps or cover. Screw up complete bumper onto bumper bracket and with fender support.

Detaching

1. Remove plastic plugs from bumper overrides and undo bolts. Remove overrides.



Fig. 79

2. Undo quarter bumper bolts at wing bracket and side member as well as on center section, detach quarter bumpers.



Fig. 80

3. Remove trim strips and sealing strips.

Fitting

1. Bolt on quarter bumpers so that they line up with the wheel cutout of the fender and the light box. It should be ensured that the bumpers are parallel with the fender bottom edge. If necessary re-align bumper bracket.

2. Push in bumper center section. Here the center section should not wedge at the sides, nor should there be more than 5 mm (0.20") clearance between it and the quarter sections.

3. Remove sections and cellulose.

Installing

1. Install trim strips and aprons on quarter sections.

2. Cement sealing strips on fender bottom edge and center section. Pull sealing strips into center section.

3. Install quarter sections, ensuring that the sealing strip makes contact at all points. Push center section onto bracket and bolt to the quarter sections at the bottom ends. Fit a spacer on either side.



Fig. 81

4. Fit overrides on inner edge with packing piece and bolt tight. Fit plastic plugs in top screw holes. Trim off any projecting sealing strips and packing pieces.

Removal

1. Open lid.
2. Unplug contact on trunk compartment light.
3. Undo the two M 8 hexagon bolts on each of the hinges, Remove lid.
4. If necessary renew hinges or pneumatic springs (note difference between pneumatic spring for front and rear lid!).
When fitting the plunger of the pneumatic spring should be fixed on the trunk compartment floor.

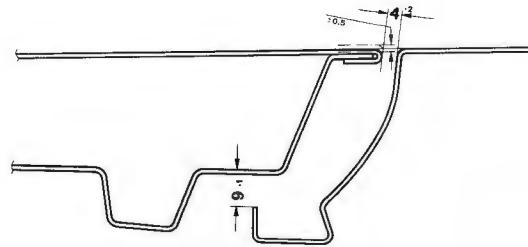

Fig. 83

Fitting

1. Place lid on hinge and secure loosely with bolts.



Fig. 82

2. Adjust rear lid gap to 4 - 5 mm (0.16-0.20").
Regulating height. Lowering lid: By tapping on the contact face of the hinge on the lid frame.
Setting lid higher: A suitable piece of wood is wedged between the gutter and the lid frame and the lid pushed to accordingly.



Fig. 84

3. Fit top and bottom lock sections. The lock pin must locate at right angles and in the center of the catch for the lock to close properly. The height can be altered by turning the lock pin.
Tension the spring of the lid lock with the cable. If the cable shears the catch opens automatically.

- Adjust gap from fender as per sketch.

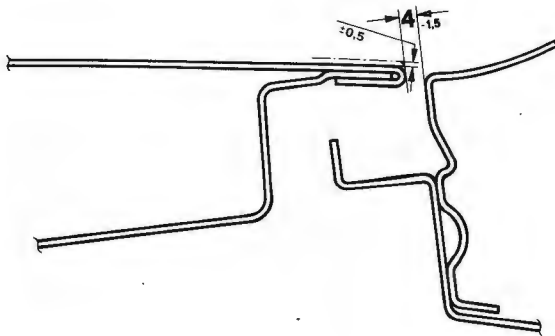

Fig. 85

- Set the lid to the same height as the fender joint edge. In the front section of the lid frame there is a screw hole on either side for adjustable rubber pads which support the lid at the sides.



Fig. 86

- Set top edge of wheel arch panel to 9 mm (0.35") clearance from lid bottom edge to ensure the necessary contact pressure for the sealing strip.
- It should be ensured that the front edge of the lid lines up with the two grilles and lies parallel to the bumper.
- Before removing the lid a pilot hole should be drilled through hinge and lid frame. Unbolt lid for cellulosizing.

Installation

- Cement rubber sealing strips in position.
- Secure lid at hinges in accordance with pilot hole. If the height setting of the lid has to be adjusted a washer should be placed under the rear bolt between hinge and lid frame to raise the lid.
Lowering: place washer under front bolt.



Fig. 87

- Install trunk compartment light and secure cable. Secure badge with underlay by means of Mecano-Speed nuts.
- Check lid lock and carry out final adjustment.



Fig. 88

Removal

1. Open lid.
2. Unscrew number plate lights. Pull cable out of lid frame.
3. Undo air intake grille.
4. Undo bolts on lid hinge and remove lid.
5. If necessary change hinges and pneumatic spring. (Note difference between pneumatic spring for front and rear lids!)

Fitting

1. Bolt on cover.
2. Set top lid gap to 4 - 5 mm (0.16-0.20"). Adjust height with washers.

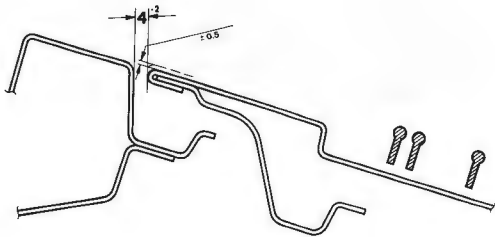

Fig. 89

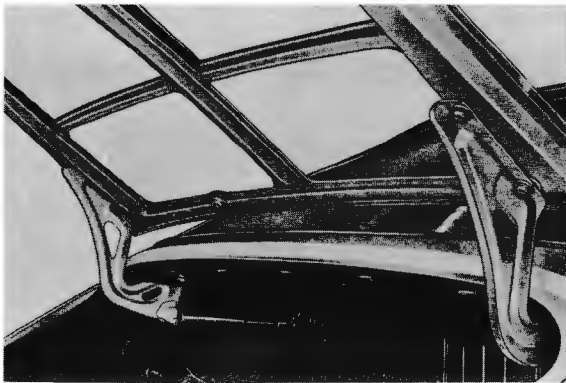

Fig. 90

3. Install and adjust lock. Tension spring with cable.

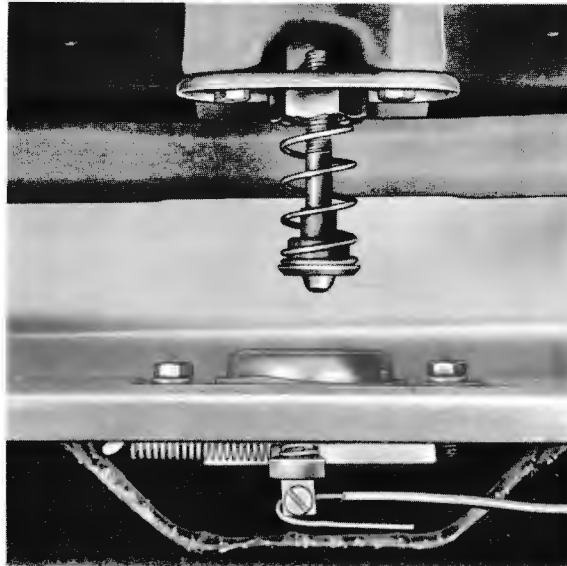

Fig. 91

4. Align gaps to the fenders according to sketch. The lid bottom edge must line up with the fender edges, rectify if necessary. Adjust height by rotating lock pin.

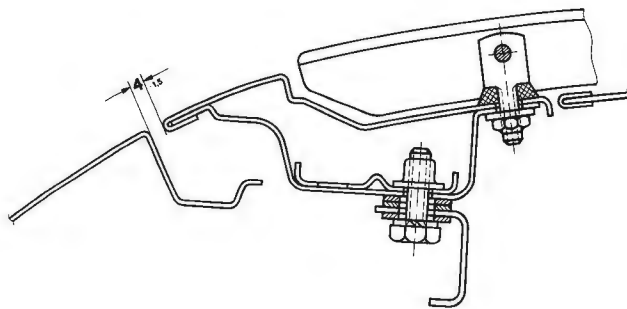
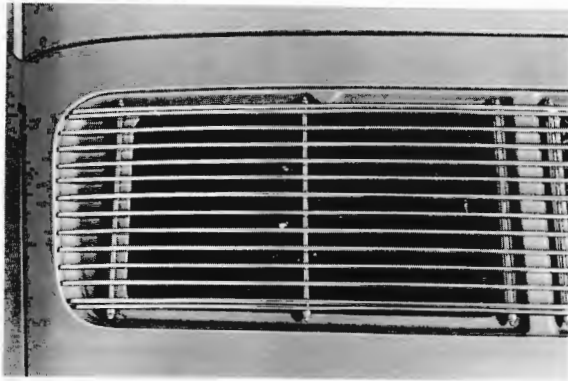

Fig. 92

5. Screw in adjustable rubber pads. Drill pilot holes and unbolt lid for cellulosing.

Installation

1. Install lid in accordance with pilot hole.
2. Pull in cable and install number plate lights.
3. Install air intake grilles with underlays. Affix Porsche insignia and type insignia with Mecano-speed nuts.
4. Check lid and make final adjustment to lock.



old model

Fig. 93



new model

Fig. 94

General

The electrically operated sliding roof is operated from a switch on the instrument panel.

The drive motor is connected to the gear by a short flexible shaft and fitted in the rear roof section. These components together with the tubular girder are accessible through a zipper in the roof lining.

The slip coupling fitted protects the drive from damage. At the same time injuries caused through jamming are also prevented.

In the event of failure of the electric drive the sliding roof can be operated by means of an emergency hand crank.

15 B0

REMOVING AND REINSTALLING SLIDING ROOF

Removal

1. Open the sliding roof approx. 10 cm (3.9").
2. Undo clips on front edge of top of sliding roof.
3. Push sliding roof top fully back.
4. Close sliding roof.
5. Remove left-hand and right-hand front guides by undoing the two screws.
6. Lift off spring catch of rear guide and turn sideways.
7. Remove both screws on the rear guides and detach cover reinforcements.
8. Lift sliding roof and remove forwards.



Fig. 95

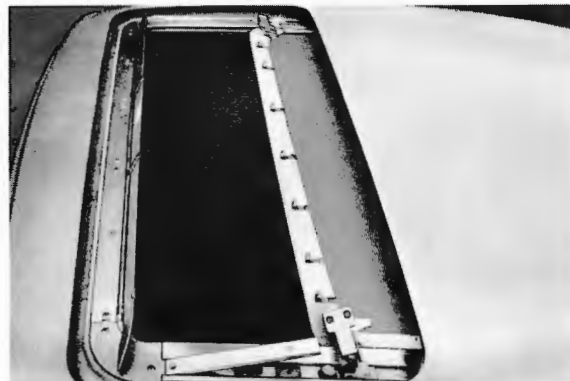

Fig. 96

9. Remove one of the left-hand or right-hand guide tails forwards; for this purpose the spacer should be unscrewed first.
10. Remove top frame.

Installing

1. Cement velvet strips at front of roof cutout and at sides as far as under the rear curvature.
2. Cement velvet strips on sliding roof cover including the radius. Cement on the rear sealing rubber with the lip against the velvet strip.

Note!

When the sliding roof is closed there should be no gap or difference in height between the two velvet strips.

3. Introduce guide rails into the pegs and tube ends at the rear of the sliding roof base. This locates the guide rails at the rear.
4. Introduce rear guides with operating cable in front into the raised rails and grease lightly. Before fitment the operating cable and drive pinion should be checked for wear and renewed if necessary, to ensure positive operation it is advisable to renew both guides with operating cable.



Fig. 97

5. Assemble cable covers and wind deflector.
6. Introduce top frame into guide rails, push to the rear to its farthest extent and secure the guide rails with the spacers.
7. Insert sliding roof cover and secure the guides at the front so that the cover has no more than 1 mm (0.04") side play.
Do not forget to fit safety plates!



Fig. 98

8. Adjust guides at the rear so that the reinforcements can be pushed in and with the guides bolted on the cover. Swivel leaf springs under the guide pins.
9. Adjusting height of sliding roof.
 - a. Slacken front guides, turn knurled nuts, by this means the sliding roof can be adjusted for height.
 - b. If the front guides are turned round further height adjustment can be made. Lateral adjustment is effected by moving the front guides.
 - c. Rear height adjustment is carried out by means of the adjusting screws of the rear guides.



Fig. 99

10. Bolt on gear. Check sliding roof for free running and parallel location.
11. Pull forward top frame and push the hollow clips into the cover frame.
12. It should be ensured that the top lining is not loosened at the roof frame by the movement of the sliding roof. If necessary remove the sliding roof cover. Carefully cement the top lining in position. Cement over a strip about 70 mm (2.75") wide to prevent any further loosening of the lining. Pull plate downwards until the cover does not rub during motion.
13. The friction action of the coupling can be increased by the addition of coupling washers under the gear bolt. However, the slip coupling action must come into operation when overloaded (end positions), as otherwise the electric motor would burn out.
14. Fix plastic cap on gear.
15. Clean water passage with compressed air or flexible steel cable, e. g. old operating cable.

Manual operation

If the electric drive fails the sliding roof can be operated by means of the emergency manual crank. The manual crank is fitted as follows:

1. Open zipper.
Detach plastic cap on gear and remove screw with the screwdriver end of the manual lever. Remove the spacing washers fitted. Ensure that these are not lost.
2. Screw the manual crank into the gear by means of the knurled nut. The teeth on the crank must locate in the groove in the gear, then tighten knurled nut. The sliding roof can now be operated by the crank.

Sources of failure: motor defective - battery too low - fuse burnt out - bad cable contacts.

Sliding roof lid lifts up on one side only

1. The lifting piece (angle metal tab on cover fitted with plastic wedge) is not engaging on the ramp.
Remedy: align lifting pieces so that they engage fully on the cap shaped ramps.
2. Back of guides, operating cable or drive pinion damage.
Remedy: renew damaged parts.
3. Locating piece set too high or too low.
Remedy: alteration of height by means of adjusting screw of rear guide.



Fig. 100

4. Wind deflector flaps.
Remedy: the guide plates should be indented on the top edge with a screwdriver close to the retaining lugs, which will eliminate the play between the two faces.

Removal

1. Open zipper and after removal of the two fixing bolts let gear hang loose.
4. Before securing the second rail insert top frame and push to the rear.



Fig. 101



Fig. 102

2. Unscrew the spacer of the second guide rail and pull guide rail out forwards.
3. Pull out cables and check condition. If damaged wherever possible renew both cables to ensure positive sliding roof operation.

Installation

1. Grease the cables and push into the tubular supports until the threaded plate is in the rear part of the sliding roof opening.
2. Push the guide rails into the cables and push to the rear until the end of the tube and the plastic pin in the rear part of the top frame slide completely into the rail section and thus secure the guide rail at the rear.
3. Secure one guide rail with the spacer.
5. Adjust cables with fixing plate on both sides evenly to about 5 cm (1.96") before the end of the rear roof cutout.
6. Insert gear and secure.
7. Insert sliding roof and bolt cables in position with reinforcements. Engage spring catch.
8. Secure front guides.
9. Fully close sliding roof and adjust for height and uniform gap. If necessary undo gear to obtain parallel location of sliding roof. Then re-secure gear.
10. Alteration of height at front by means of knurled nuts, at the rear by adjusting the locating piece bolt.
11. Ensure even gap at sides by moving guides.
12. Open sliding roof approximately 10 cm (3.93") to the rear and pull top frame forward, push clips into sliding roof.
13. Check sliding roof for ease of operation.
14. Close zipper and clean any dirt off top lining.

Removal

1. Open zipper.
2. Disconnect electric cable.
3. Undo gear.
4. Unbolt motor with fixing bracket from roof frame.
5. Unscrew fixing bracket from motor and renew motor with flexible shaft and gear.



Installation

Installation should be effected in the reverse order, check sliding roof for function, close zipper.

Fig. 103

1. Remove and reinstall top frame as described under sliding roof cover.
2. Remove damaged lining from top frame. Remove remains of old adhesive.
3. Cement Moltoprene strips to the underside of the front and rear top frame cross piece.
4. The top frame lining should, if it is of unperforated leathercloth be joined to the center cross piece with a retaining strip by the seam in the center. Perforated leathercloth should be backed with a plastic sheet and sewn to the retaining strip to make dustproof.
5. Place top frame on the ready-sewn lining so that the seam of the lining locates on the front side of the center cross piece. Cement retaining strips on both sides of the center section. Cement plastic sheet around the underside of the frame. Stretch the lining evenly and cement carefully on the top side. Cut out the corners to avoid overlap, so that the top frame runs satisfactorily in the guides.

BODY INTERIOR

General

The whole of the underside of the vehicle including front, engine and rear compartment with door interiors plus the underside of the front lid are sprayed with sound-proofing material which also has an insulating effect. The rear compartment, the back panel and the side panels together with the engine compartment and the inside of the roof are additionally covered either with bitumen paper, bitumen felt, Moltoprene, felt or cork matting.

The noise level is reduced still further by means of cemented in carpets which according to vehicle type are of bouclé, velour, or perlon.

The floor is covered either with rubber mats or the appropriate carpets.

The side and rear panel trim and door paneling is covered with padded leathercloth.

The roof lining is of perforated leathercloth and is located in the roof frame on four stays (Coupe) and cemented along its outer edge.

The instrument panel is edged at the bottom with a padded cover strip (knee strip) which is fixed to the instrument panel by means of four screws. The top covering of the instrument panel is single piece up to the 1968 model and two piece as from the 1968 model.

The screen plates for the heater jets are fitted on the top section of the instrument panel with securing clips.

The instrument panel on types 912 and 911 T is paneled with aluminum plate, whereas the other models have padded leathercloth covers, which were in wood on previous vehicles.

Heating and ventilation is conducted via three jets to the windshield, by two slides on the side members into the foot compartment and to the rear window glass. Available as special option is an additional heater unit with blower which is fitted as standard on the 911 S type.

The rear vision mirror can be dipped and is fixed so that it springs out of its frame on impact.

The sun visors are padded and there is a make up mirror on the passenger side. The glovebox has a locking magnetic catch. The interior lights are in the side roof members in the Coupe whereas with the Targa type the interior lights are located on the interior cover of the safety bar.

Removal

1. Disengage catch by lifting lever.



Fig. 104

2. Push seat forward until the seat rails slide on the guide rails.
3. Lift out seat.
4. The outer seat rail bracket can be adjusted by slackening the screw fixings. By this means it is possible to cure both stiffness and rattling of the seat in the guides.

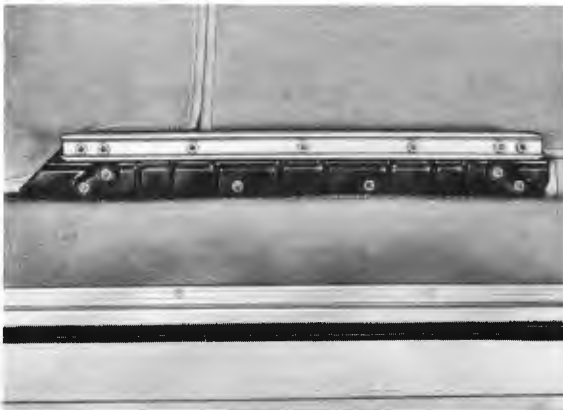

Fig. 105

Installation

1. Before installation of the seat the guide rails should be greased. When placing in position it should be ensured that the seat cover is not damaged by the guide rails.
2. Push seat to the rear and engage catch lever in required position.

The rubber underlay on the seat frame should be renewed if badly worn. This will prevent ratting of the seats.

The front seats can be raised by about 20 mm (0.79") by fitment of raised seat rail brackets on the outside and seat rail packing piece in the center.

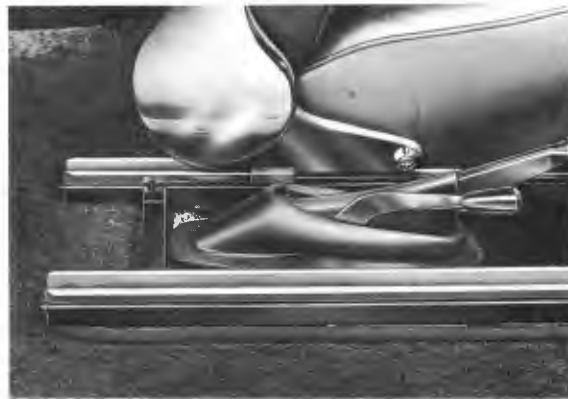

Fig. 106



Fig. 107

Removal

1. Remove seat.
2. Unscrew defective half of bracket first at backrest and then at seat frame.



Fig. 108

3. Push bracket half out of square on seat frame. Pull the bracket out of the connecting tube between the brackets and if necessary renew.



Fig. 109

Installation

1. Push bracket half on to the connecting tube.
2. Secure bracket on seat frame with plain and toothed washer.
3. Position the arm for securing the backrest parallel with the second bracket half, then bolt up to the backrest.
4. Check the reclining seat bracket for proper function.
5. Check the backrest locking catch and if necessary renew rubber underlays on seat frame.
6. Install seat and check the operation of the reclining seat bracket with the seat occupied.

Up to model 1968 the bracket for the headrest is fitted on the rear of the backrest.

1. The brackets with knurled screws should be fixed with two each chromium plated self-tapping screws approx. 30 mm (1.18") below the seat lining seam and approx. 135 mm (5.31") from the outside edge of the backrest. Fixing plates should be fitted in this position through the lining of the backrest and on these are fitted the brackets corresponding with the headrest guides.



Fig. 110



Fig. 111

The backrests are swivel mounted by means of an external bracket and are located on the inside by means of a dowel pin above the transmission tunnel.

The rear paneling of the occasional seat backrest is fixed to the luggage compartment floor by two self-tapping screws so that when the backrest is folded forward this covering (carpeting) lies flat without wrinkling.

The occasional seat backrest can be detached when these screws are removed.

Installing should be carried out in reverse order to removal of the seat back.

The occasional seat squabs are only cemented in position.



Fig. 112

Removal

1. Remove windshield and rear window glass.
2. Undo catches on the rear vent windows.
3. Remove trim strips and rear panel covering.



Fig. 113

4. Remove sun visors and interior mirror together with interior lights and clothes hooks.
5. Where necessary remove door sealing rubber.
6. Remove damaged head lining all round if necessary cutting out and disengaging stays. Where necessary remove pillar paneling.

Installation

1. Cut loops for fixing wires in the new roof lining after marking on both sides, approx. 13 cm (5.11").
2. Push transverse stays into the loops and put rubber caps on the wire ends. Check used rubber caps for damage (bracket creaking noises). Cement sound-proofing paper to roof interior, if necessary re-cementing any loose sections.

4. Fix paper strips at the rear of the roof lining on the trunk compartment floor with self-tapping screws.



Fig. 114

5. Stretch the lining forwards pulling onto the windshield pillars. Then stretch the lining sideways, evenly on either side, cut to the correct size and cement. When doing this ensure that the lining is cemented around the metal edges and is additionally secured with clips around the windshield, back and side windows. Where pillar paneling has been removed re-cement in position.
6. Cement in door sealing rubber. Fix sun visors, interior mirror and interior lights. Reinstall windshield and back window glasses, refit trim strips and rear paneling.

The carpets are supplied ready cut to size. According to vehicle type they consist of Perlon, Bouclé or velour in various colors. The floor covering varies according to type consisting of either rubber mats or carpets in various colors and qualities. The carpets should be cemented in in the following order.

1. Tunnel carpet rear.
2. Carpet for seat moulding center (for occasional seats).
3. Carpet for left- and right-hand side paneling (pocket section).

The pocket should be secured at the front with an upholstery nail.

4. Left- and right-hand side member carpet. When fitting the heater slide use self-tapping screw 4,2 x 23 mm at the front and 4,2 x 19 mm at the rear.
5. Carpet for heel board.
6. Carpet for rear seat moulding.
7. Cement in occasional seat squab.
8. Screw in transmission tunnel cover.
9. The left- and right-hand side paneling should be pushed to the rear and the side paneling secured under the cover on the wheel arch with a self-tapping screw.

The cover should be cemented at the door cutout around the metal moulding for the door seal. The front floor covering is fixed top front by means of eyelets. The trunk compartment is carpeted, the side sections are cemented in. The trunk compartment mat is attached by eyelets under the windshield frame center section.



Fig. 115



Fig. 116

The bottom of the dashboard is covered with the knee strip. The dashboard facings consist according to vehicle type of cemented aluminum foil, wood paneling or upholstered leathercloth facings. The top of the dashboard is covered by a padded covering. This also covers the loudspeaker masking plate or if a loudspeaker is fitted, the loudspeaker itself and the cover plates for heating nozzles.

1. Dashboard covering single piece up to 1968 model. On this dashboard covering there are 2 M 6 bolts which are inserted forwards into the dashboard and are secured from the luggage compartment. Five clips located in the covering are pushed into the dashboard on the inside thus effecting fitment on the dashboard.
2. Dashboard covering two part as from 1968 model. For removal and reinstallation of this covering the windshield must be removed.
 - a. First detach the dashboard covering. For this purpose lift the covering with a scraper blade and pull the plastic clips out of their locating holes.
 - b. The dashboard paneling has seven M 6 bolts whose nuts with washers should be removed from the luggage compartment. In addition 3 metal tabs are attached to this paneling and are screwed to the dashboard with self-tapping screws.
3. The padded knee strip is fixed to the bottom edge of the dashboard by means of 4 M 5 bolts. When installing care should be taken to ensure that the screw fittings are tight and that the side edges locate flush, in order to avoid the possibility of rattling.
4. The glovebox lid is bolted to the dashboard by means of a hinge. It can be locked and has a magnetic catch. The inside is padded and is clipped to the lid with metal tags.
5. The glovebox shelf is secured by a clamping strip which is pressed against the dashboard from underneath by a bolt.



Fig. 117

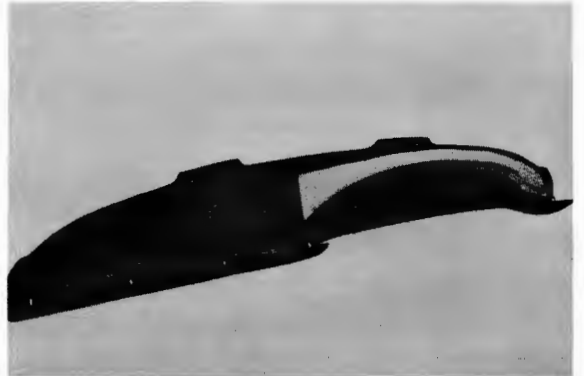

Fig. 118



Fig. 119



Fig. 120

1. The bumper trim strip part no. 901,505,041,00 is used for cars with bumper overriders and bumper trim strip part no. 901,505,041,30 for cars without overrider.
For types 911 S and 911 L USA moulding part no. 901,505,047,50 is fitted.
2. When fitting trim strips or mouldings it should be ensured that the seam of the underlay is underneath. Starting at the center the bolts should be fitted with washer, spring washer and nut and tightened. This ensures that the trim strip seats properly along the bumper.
3. Front moulding part no. 901,505,405,50 for the 911 S type moulding should only be pushed on after fitment of part no. 901,505,405,50. Here the moulding should be pushed onto one end of the moulding strip. Further fitment is effected by sharply bending the moulding thereby bending the locating lips far enough apart for them to engage over the section of the moulding strip and with subsequent unbending to seat around this section.

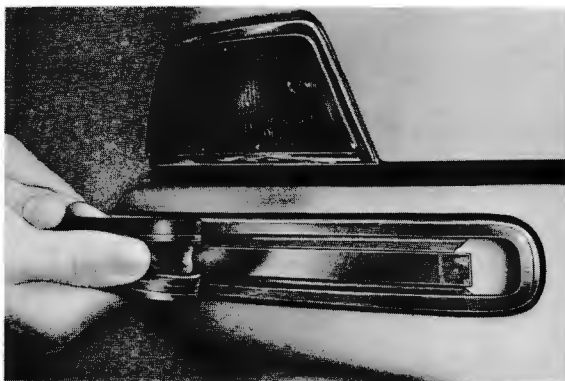

Fig. 121

4. The front bumper overriders should each be bolted to the bumper with two 80 or 90 mm (3.14 or 3.54") long cylindrical head bolts. The paintwork of the bumper is protected from damage by plastic mouldings which are pushed on to the overriders during fitment.

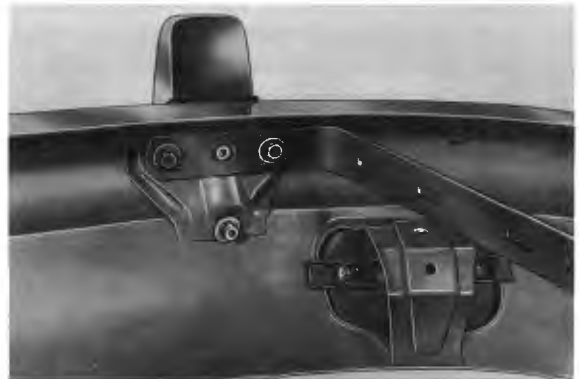

Fig. 122

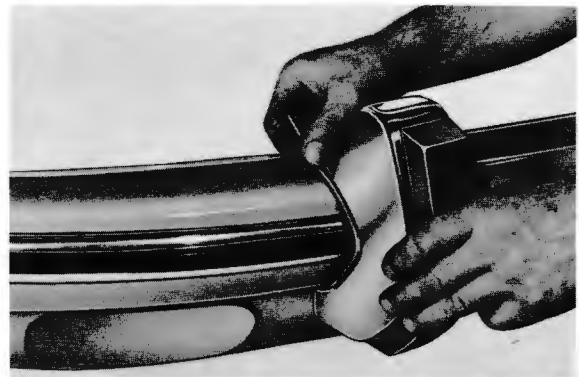

Fig. 123

5. As special option the overriders can be fitted with rubber pads. For subsequent fitment the overriders should be provided with three slots and the pads screwed on.
6. The holes in the bumper are either fitted with foglamps or are sealed with coverplates cellulosed in the car color. These are fixed to a clamp bar with two bolts and are thus joined to the bumper.

7. The number plate is bolted to the front bumper on brackets.
8. The rear number plate is fixed on to the bumper center section and has rubber underlays. Unauthorised removal of the number plate is made more difficult by bolts with washers which are fitted with self-locking nuts.
9. The rear bumper overrides are fitted onto the brackets of the corner bumpers. The center section is first pushed on and then locates with a seal on either side against the rear side members. The overrides are fitted on the inside with a plastic moulding. The two top holes in the overrides for the fixing bolts are sealed with plastic plugs.
10. The quarter bumpers are braced with a plate at the front to prevent damage through contact with the rear wheel. The bracing plate has an underlay of Terostat strip and is fitted with a moulding on the outside edge. These are fitted to the bumpers with half-round rivets which are secured with Benzing Quicklocks.

Rear bumper trim strip:

The rear bumper trim strip are assembled in a similar manner to the front bumper trim strips.



Fig. 124

1. The front grilles should be fixed on the front fenders so that they lie parallel with the winker and sidelights as well as with the front lid. On the early model cars these are fixed by four self-tapping screws at the corners. If necessary the fixing points should be realigned to alter the location of the front grilles.
2. The present design is fixed with two self-tapping screws which are secured by snap nuts.
3. For the additional fitment of Halogen driving lights and fog lights the grilles should be cut through to permit fitment of these lamps.

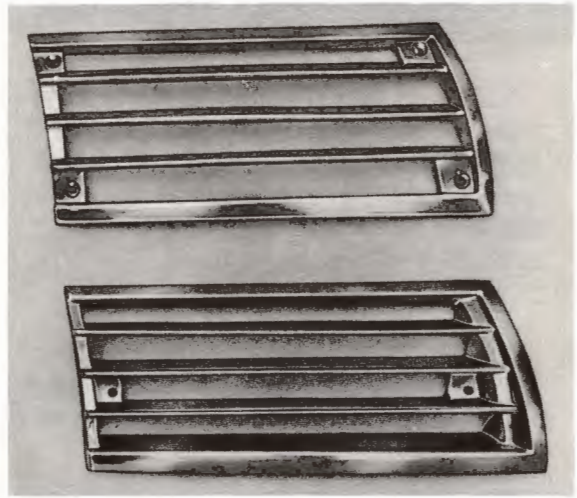

Fig. 125

1. The air intake grille is fixed on the rear lid by means of 8 screw plates with underlays. As from model 68 the air intake grille in modified form is fixed on the rear lid with 6 Allen screws and there is no center web. When fitting it should be ensured that the underlays provided for the purpose are in fact fitted to prevent any possibility of noise.
2. The Porsche letters and insignia, type and Sportomatic insignia on the rear lid as well as the badge on the front lid should be secured by means of Mecano Speed nuts.

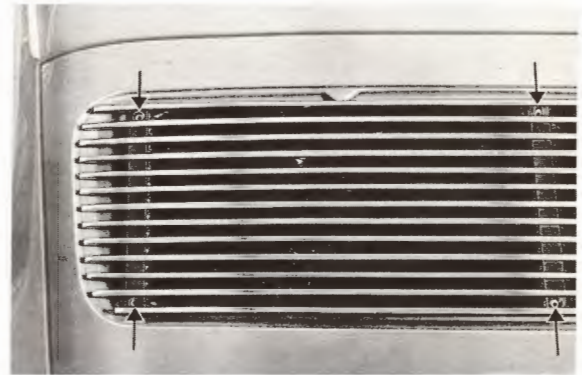

Fig. 126

The trim strip under the door is of three different designs according to vehicle type.

1. Trim strip 901.559.011.22 is used on all vehicles except S and L USA. It is provided with underlays and is secured by self-tapping screws. The filler strip is then pressed into the trim strip with a suitable scraper blade.
2. Trim strip 901.559.105.50 is also secured by means of self-tapping screws. With a modified section with thick rubber insert it has been used for all S types up to model 68.
3. As from model 68 trim strip 901.559.105.52 is being used for 911 S and 911 L USA; this covers the whole length of the treadplate. Additional end pieces are fitted to protect the paintwork from stones.



Fig. 127

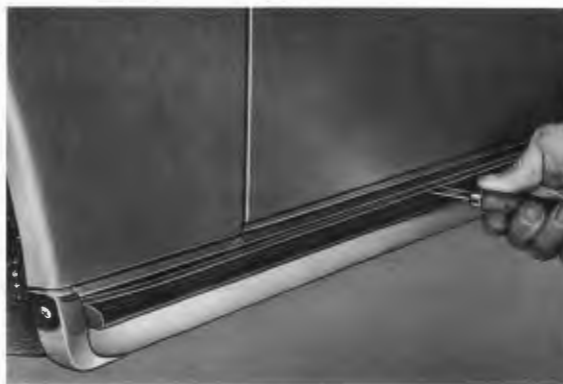

Fig. 128

General

When driving fresh air can be conducted from the windshield center section via a control box into the car interior. The grille fitted on the windshield center section prevents the ingress of air foreign bodies. A water chamber fixed under the control box conducts any water away downwards via a connecting hose and pipe. A control lever on the dashboard regulates the flow of fresh air. The fresh air can be switched over to warm air and flows through the nozzle of the fresh air chamber as well as through connecting hoses via the outer heater nozzles on the dashboard into the car interior.

Removal

1. Unscrew the fresh air grille from the windshield center section.
2. Undo the wing nut of the clamp bar for the water trough, disengage clamp bar and remove plate.
3. Pull water trough downwards and disengage from water drain hose. The sealing ring on the water trough can then be renewed and the fresh air chamber reached. The fresh air chamber itself is welded to the dashboard top section.
4. Undo cable on control lever from front luggage compartment.
5. Unscrew bolts from left- and right-hand support brackets on control box, remove support bracket outwards, then the fresh air control flap can be extracted.
6. Extract tension spring securing control lever, release cable and renew or grease control lever as necessary.
7. When removing the cable and guide tube for the fresh air control flap it is necessary to remove the screenwiper unit beforehand. Then pull the tension spring out of the sleeve at the back of the control box, unscrew the securing clip at the back of the guide tube, then disengage and remove cable. If the control lever is stiff replace plastic tube with a metal tube.



Fig. 129

8. Installation should be carried out in reverse order. Here it should be ensured that the water chamber is placed in position and fitted correctly so as to prevent the entry of water into the rear compartment.

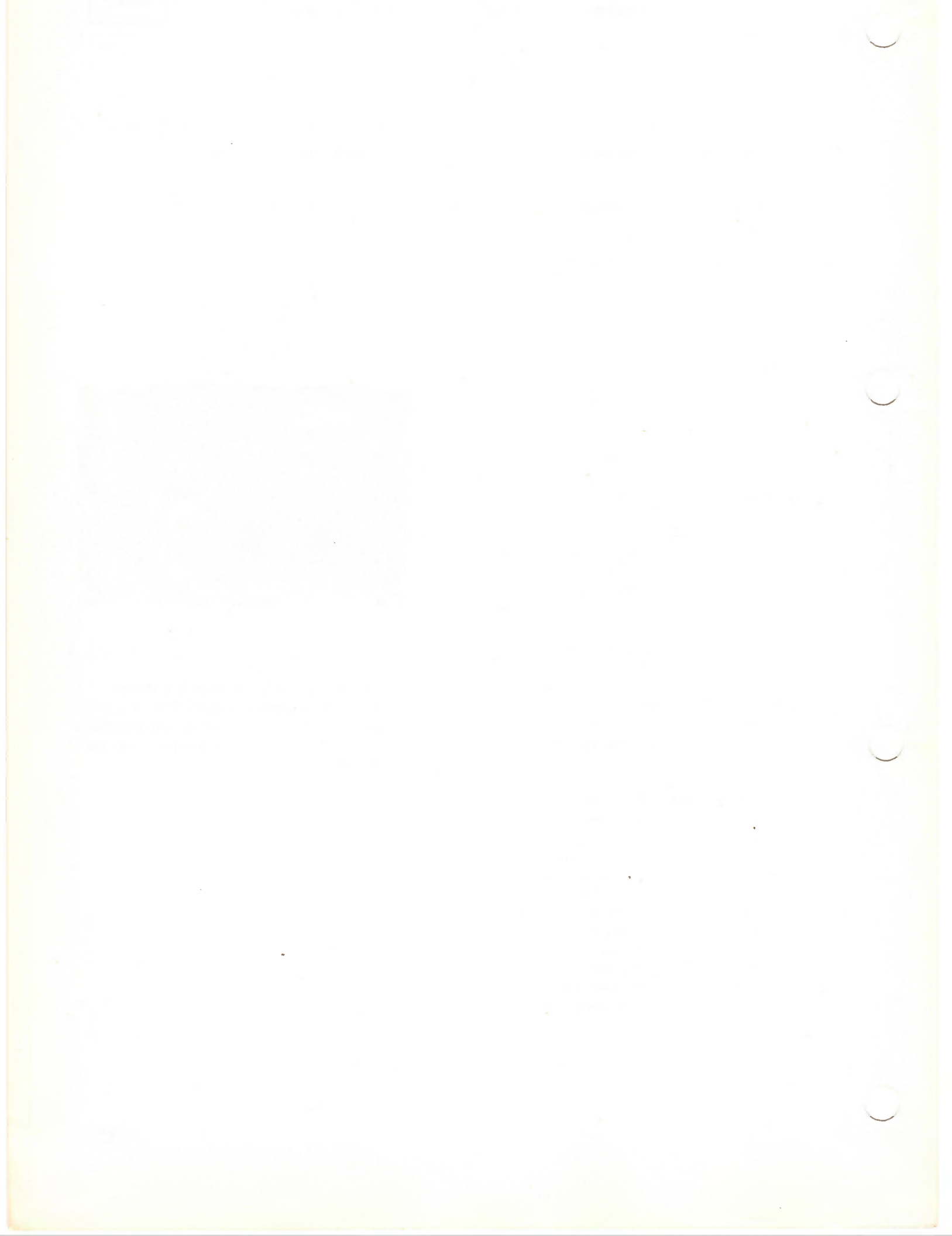

BODY SHOP EQUIPMENT

To carry out work on Porsche bodies which includes in addition to the normal removal of dents and fitting the alignment and renewal of buckled and distorted frame members, the following equipment is necessary.

1. General workshop equipment and tools:

Celette alignment and assembly rig

Dozer with accessories

Hydraulic press with pressure piston and further accessories

Spot welding unit with center punch, tongs with various capacities

Acetylene welding unit, flame cutter and torch inserts of various sizes

Clamps and screw clamps of various types together with the usual body beating out tools

2. Special tools:

P 852 Template for windshield

P 853 Template for windshield - Coupé

P 854 Templates for left- and right-hand rear vent windows

P 856 Template for rear window cutout - Targa

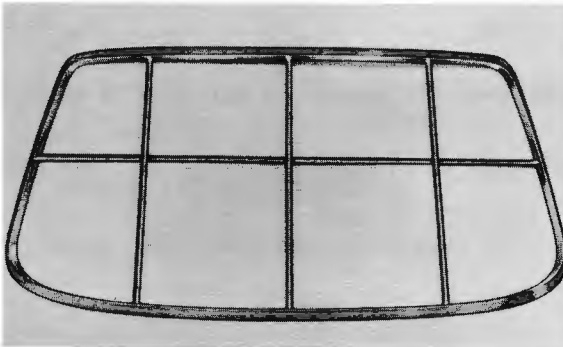

P 852

Fig. 130

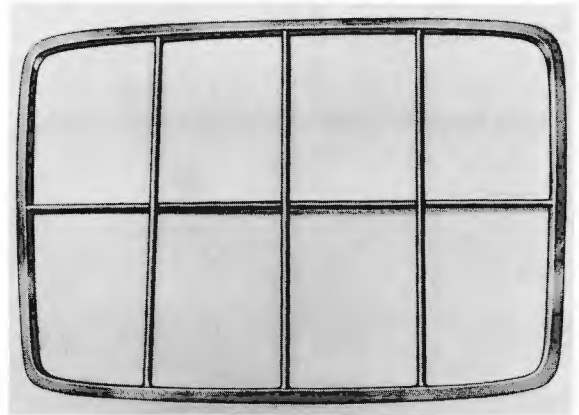

P 853

Fig. 131

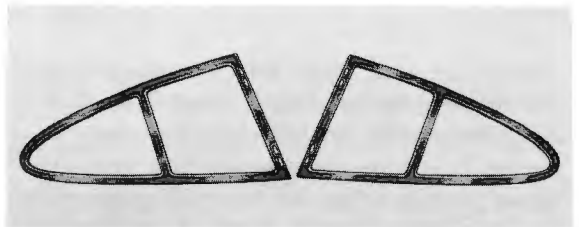

P 854

Fig. 132

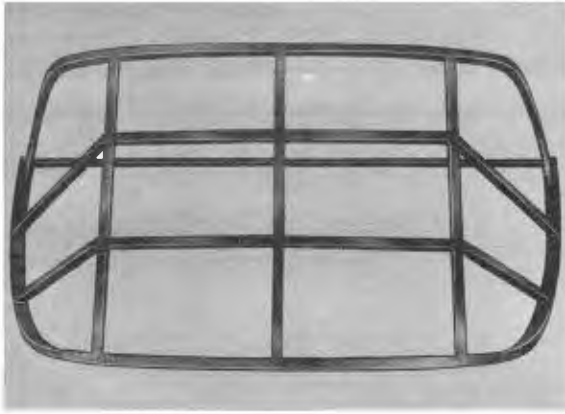

P 856

Fig. 133

Note on special tools P 852, 853, 854 and 856. All window cutouts can be checked for truth with these robust templates. They are in addition used for renewal of the roof as well as the front and rear end sections where these affect the window cutouts.

P 850 Front axle gauge

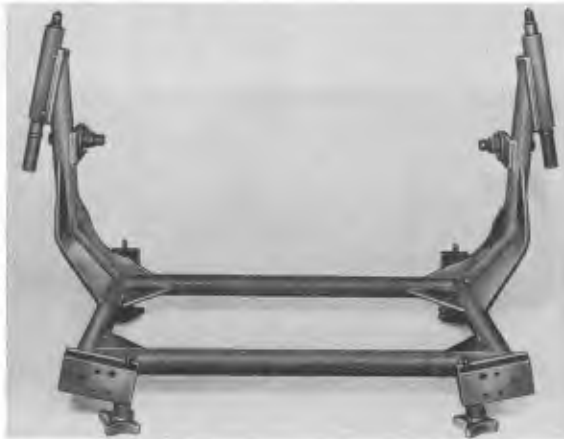

P 850

Fig. 134

Note on special tool P 850. This gauge is used for checking the attachment points of the front wheel suspension. For this purpose it is only necessary to remove the complete front axle. If it is not possible to bolt the front axle gauge to all attachment points on the body, or it is found that there are variations in dimension in excess of the permissible tolerances, an alignment check of the vehicle must be made on the Celette rig.

B 56

P 290 For installation and removal of door hinge pins



P 290

Fig. 135

Self-constructed gauges:

P 1000 Door and lid flange gauge

P 1001 Door and lid gap gauge

P 1003 Hinge adjusting plate

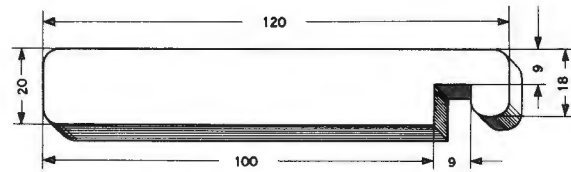

P 1000

Fig. 136

Material: flat steel 8 - 10 mm (0.31 - 0.40")

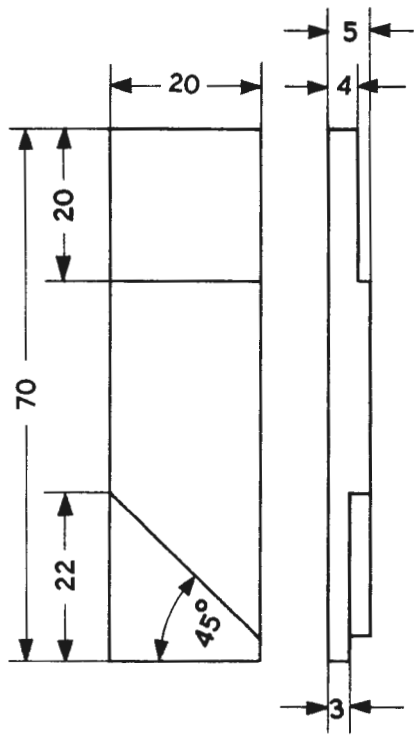

P 1001

Fig. 137

P 1003

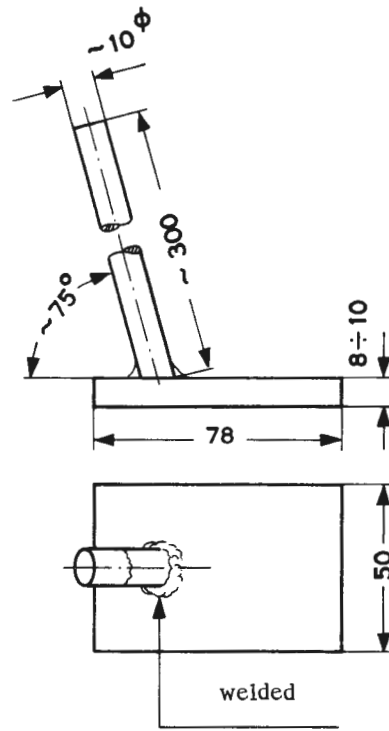

Fig. 138

Before the body can be placed on the Celette rig all components of front and rear axles, engine, transmission, fuel tank, battery etc. must be removed.

Summary of test points with tolerances:

1. Left- and right-hand supports for suspension arm brackets
Permissible tolerance: ± 3 mm (0.12"), but not more than 2 mm (0.08") difference between left and right.
2. Supports for auxiliary brackets with stay
Permissible tolerance: ± 3 mm (0.12"), but not more than 2 mm (0.08") difference between left and right.
3. Top shock absorber supports front and rear
Permissible tolerance: ± 3 mm (0.12")
4. Supports for outside of rear axle for rear axle transverse tube
Permissible tolerance: ± 0.5 mm (0.02")
5. Supports for transmission mounting
Permissible tolerance: ± 0.5 mm (0.02")
6. Supports for engine mounting 911
Permissible tolerance: ± 1.0 mm (0.04")
7. Supports for engine mounting 912
Permissible tolerance: ± 1.0 mm (0.04")
8. All attachment points must seat properly on the Celette rig and fitment must be possible without straining.



Fig. 139

Special tool:

Celette Alignment and Assembly rig

General

The body front section is a supporting section of the Porsche 911 and 912. When renewing it should be ensured that the weld seams are made properly. The rigidity of the vehicle repaired in this way will be equal to that of a new car.

This repair will be necessary if the front frame section of a car has been distorted or pushed into the car interior in an accident.

Preliminary work

Before the front section of the vehicle is removed all components such as doors, lids, fenders, axles, engine, transmission, steering, glass, fittings, seats etc. must be completely removed.

Body work

1. Prepare new section as per illustration, part off all parts not required. The primer of the new section can be retained for installation, it is unnecessary to wash it off.



Fig. 140

Note!

When using a '68 model front section on vehicles prior to the 68 model the following operations should be carried out:

- a. Weld in two M 8 nuts for steering support tube.
- b. Remove the reinforcement plate for the modified steering support.



Fig. 141

- c. Blank off both holes in floor panel for twin circuit brake system.

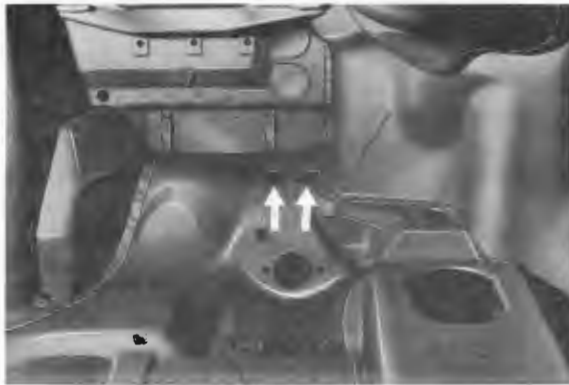

Fig. 142

2. Jack up damaged car. Draw in parting line as shown in illustration.



Fig. 143

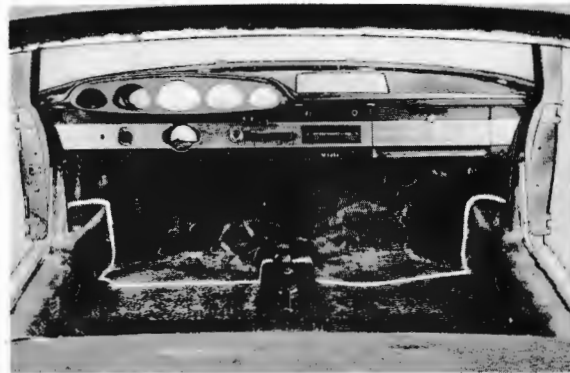

Fig. 144

3. Before parting off the front section check once again that the tunnel has been completely cleared and that no fuel or brake fluid lines are likely to be damaged.
4. Part off body front section. This is best done with a flame cutter. The location of the side cutting edge is clearly visible from the illustration. It is important that the door member and the fixing points of the hood hinges are retained as this facilitates subsequent fitting operations.

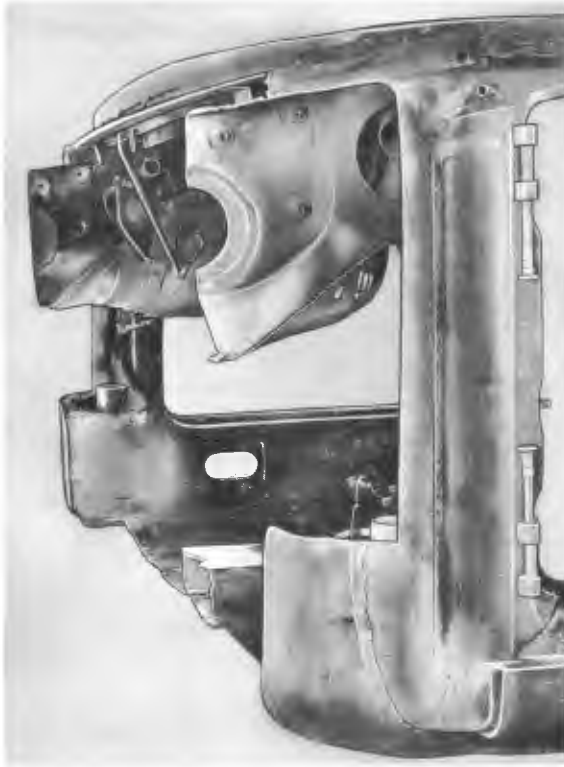

Fig. 145

5. Clean sound-proofing compound from weld seams. This is best done by heating the sound-proofing compound with a welding torch and then brushing off with a steel brush.



Fig. 146

6. Remove damaged tabs for securing cable. Trim burned off plates clean with tin snips. Do not cut off too much as the plates must later overlap.

7. Fix rear of vehicle on Celette alignment rig. Place body front section loosely on alignment rig and trim edges on new section to be welded to allow for approximately 2 cm (0.8") overlap. Mark off bottom edge with straight edge and cut off.

Note!

The tunnel cannot be overlapped, it must be matched up as a butt joint.



Fig. 147

The floor panel should be overlapped so that the new section is underneath. For extensive cutting work the body front section can be removed from the alignment rig; afterwards it must be possible to replace it without using force. Before final matching up the body section should be pushed back hard and then pushed forward again to its exact position. This eliminates any form of strain. Experience has shown that oxyacetylene welding at these places produces distortion amounting to 3 mm (0.12"). This shrinkage can be compensated for by the support brackets of the body front section being pushed forward by the corresponding distance before welding. For this purpose all location points of the whole body on the Celette rig must be determined and secured.

8. To secure the body a wooden beam should be placed over the two treadplates and pulled down onto the alignment rig on left and right-hand sides with a screw clamp.

9. Weld on body front section with oxyacetylene. This operation requires perfect continuous weld seams on both outside and underside. In addition the inside must be carefully tacked at a distance of approximately 2 cm (0.8").

10. The plates shown in the illustration are usually cut about during repair. In this case they must be removed and renewed.

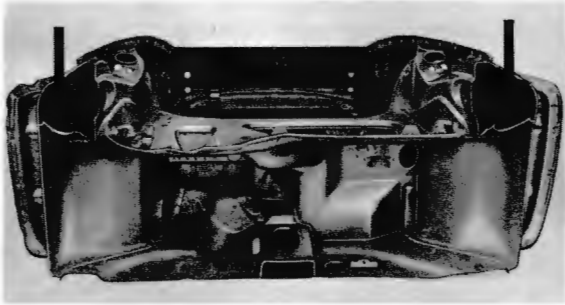

Fig. 148

11. Weld in guide tube of front lid cable.

12. Spray body front section with sound proofing compound.



Fig. 149

BODY FRONT SECTION WITH HINGE PILLARS, INSTRUMENT PANEL
AND SCREEN FRAME

33 B0

Note!

Only produced in Targa model. Can also be used for Coupé.

Parting off

1. Saw off windshield frame on Coupé according to extent of damage.
2. Part off both wheel arch panels from the side members.
3. Part off treadplates top and bottom approximately 15 cm (5.90") to the rear. Bend up top plate to the rear so that the hinge pillars can be parted off from the side members.
4. Cut floor panel right across as shown in illustration.
5. Remove damaged frame front section.

Matching up

1. Match up new section on Celette rig according to trimming of body. Here the hinge pillars should be inserted in the treadplates. The floor panel of the new section should overlap by about 20 mm (0.8") and should be underneath the old panel. The tunnel plate should if possible be trimmed for a butt joint.
2. With Coupé screen frames line up with screen template and trim. Weld on frame front section complete, weld up treadplates, match up doors, fenders and lid.
3. On Coupé remove square section tubular support for transverse tube under dashboard.

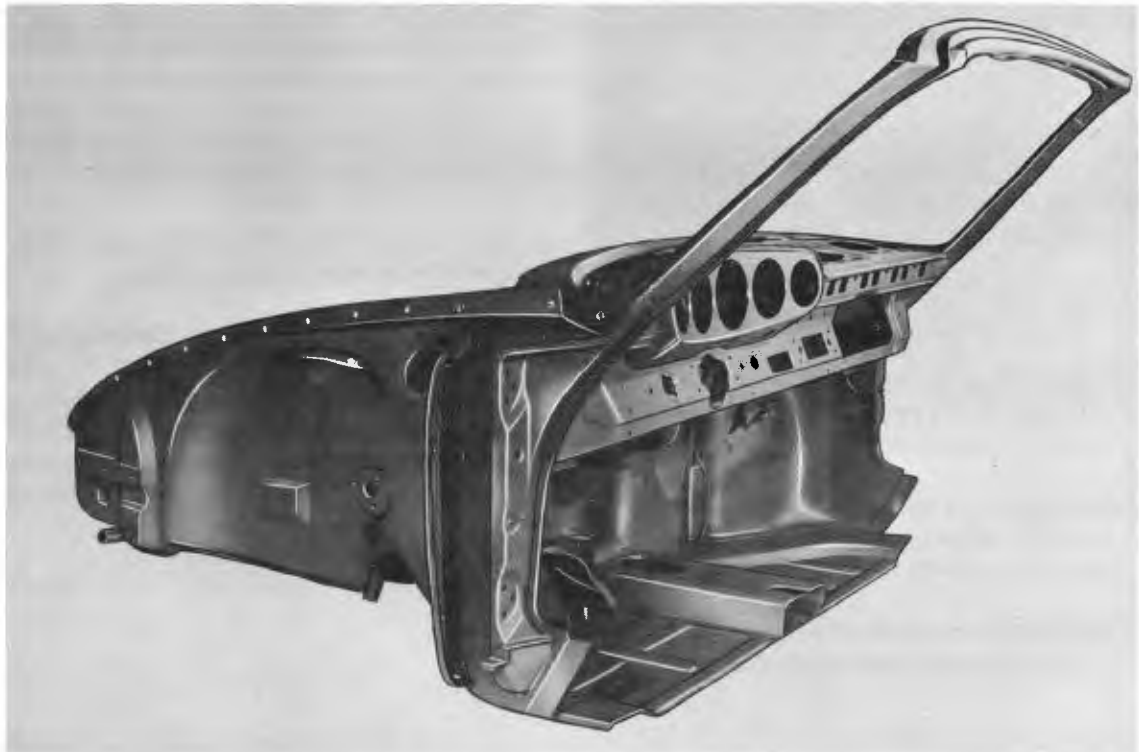

Fig. 150

Preliminary operations

1. Unbolt front bumper and both fenders.
2. Remove battery, spare wheel, screenwash tank, luggage compartment lining, fuel tank and rubber seals.
3. Remove bottom half of lid lock together with release cable.

Removal

1. With an oxyacetylene torch cut through the partition wall starting at the top working along the wheel arches down to the floor panel and then along the top edge of the floor panel.

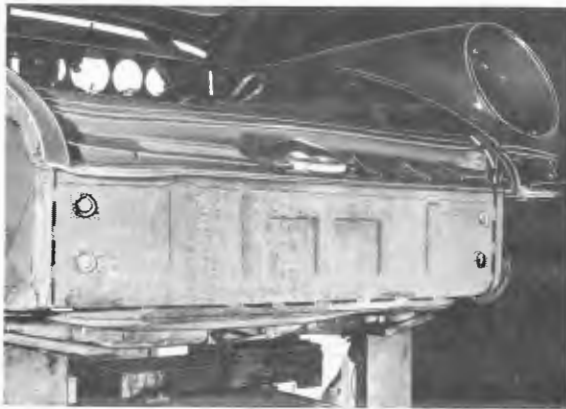

Fig. 151

2. Release the guide tube for the lid cable at the weld spots on the partition wall and twist off. Remove the partition wall.
3. Burn and cut off the remains of the partition wall with welding torch and cutters from the wheel arch and the floor panel.
4. Straighten bent panels and with a wire brush remove remains of paint and underseal.



Fig. 152

Assembly

1. Push the new section in from above. The overlap with the floor and the wheel arch should be cut off on both sides to approx. 2 1/2 cm (0,98") wide so that the new section can be pushed in sufficiently far down in front of the floor panel.
2. Tack the partition wall horizontally onto the wheel arches in alignment with the lid. The wheel arch outer edge must protrude uniformly 2 mm (0,08") on both sides over the lid outer contour to ensure a uniform lid gap.
3. Starting from the top spot weld the partition wall to the wheel arches and floor.
4. Insert the guide tube for the lid cable into the hole provided in the partition wall and weld in position. It should also be checked which places have to be re-welded to prevent the entry of water. Weld in the bracket for screenwash tank and water pump and check for proper location.

5. Install lock bottom half and adjust release cable. Check and adjust lock position in relation to top half. The peg must locate vertically in the center of the lock bottom half. If necessary move lock top half.

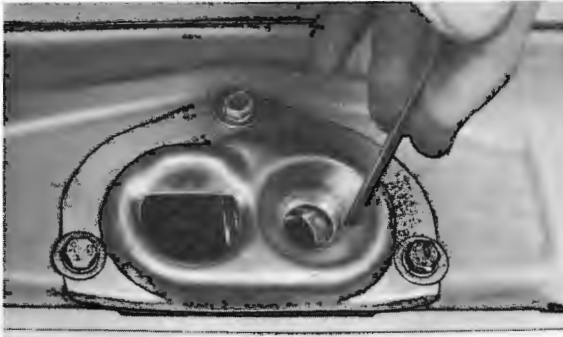

Fig. 153



Fig. 154

6. Bolt on both fenders and if necessary re-align wheel arch panel to ensure a uniform lid gap of 4 mm (0.16").
7. Offer up bumper. The section rail on the partition wall for location of the sealing strip must run parallel to the fender bottom edge and the bumper. The lid front edge should be 1 cm (0.40") above the bumper for the sealing strip to seal properly.
8. Cellulose the partition wall and coat with underseal and affix vehicle data plate with pop rivets.

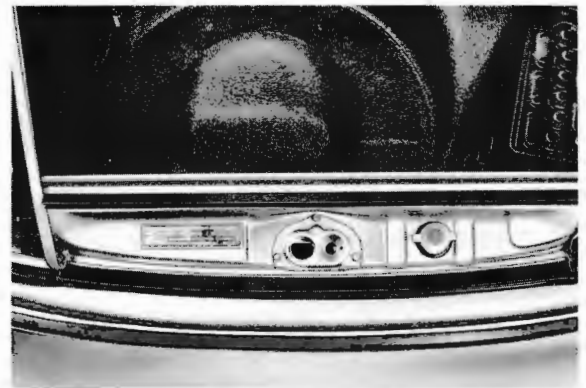

Fig. 155

Special tools:

P 1000 Door flange gauge

P 1001 Door and lid gap gauge (self-constructed tool)

Preliminary operations

1. Detach door and remove. Unbolt and remove sill trim strip and treadplate molding with cover strip.
2. Unbolt front fender.
3. Pull sealing frame out of molding. Unscrew heater slide.
4. Partially detach and roll back side member carpet and sound-proofing paper.
3. Part off the door sill at the reinforcement on the wheel arch, remove jack socket and sill plate. If the rear fender is undamaged the sill should only be parted off as far as the connecting point to the rear fender.
4. Chisel off the outer side member from the top of the inner side member as well as from underneath the rim and cut off front and rear according to extent of damage.
5. Remove metal remains with clippers and welding torch and clean the joint faces with the new sections with welding torch scraper and wire brush.

Removal

1. Part off door sill from hinge pillar, fender connecting plate and rear fender.
2. Chisel off the inside edge of the sill along the molding edge as well as under the rim.



Fig. 156



Fig. 157

- Secure body on alignment and assembly rig at the support points. Straighten bent panels with Dozer and re-align.

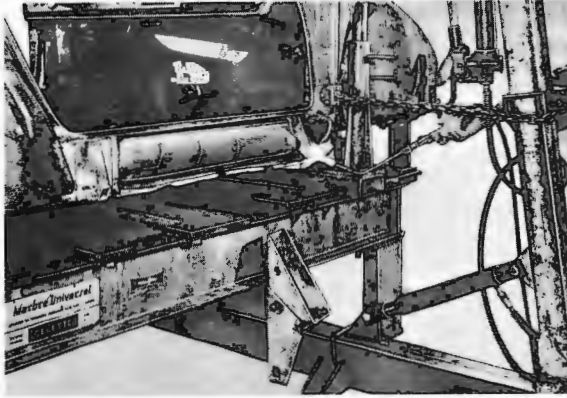

Fig. 158

Assembly

- Offer up and trim outer side members.
Note! The heater pipe should not rest on the side member (rattling).
- Spot weld both side members top and bottom, overlap front and rear approx. 2 cm (0.78") and center punch and weld. Re-hang doors.

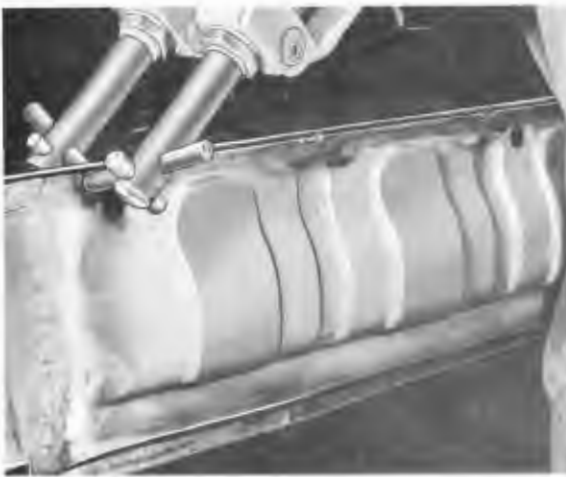

Fig. 159

- Tack sill plates at top. It should be ensured that the front joint face of the sill plate with the front fender is 2 mm (0.08") in front of the door edge. Tack the sill plate onto the fender joint plate so that the gap between door and sill plate is 4 mm (0.16").



Fig. 160

- Spot weld top and bottom joint with side member. Line up exterior contour so that there is a uniform gap with the door.
- Weld the sill plate to the hinge pillar and the fender joint plate, or spot weld. Weld the joint with the wheel arch and the jack socket.



Fig. 161

6. Weld on rear fender in alignment with door.

7. Align, fill and rub down visible weld spots as well as all irregularities and dimensional out of truth.

8. Line up front fender with door and if necessary re-align fender joint plate.

9. Check molding for sealing frame with gauge number P 1000 and rectify any out of truth on door.



Fig. 162

10. Prepare the car for cellulosing.

Special tools:

Rear vent window template
 P 1000 Door flange gauge (own construction tool)

P 1001 Door and lid gap gauge (own construction tool)

Preliminary operations

1. Unbolt rear bumper and quarter bumpers.
2. Undo rear winker/stoptlight, pull out of light compartment and disconnect cable.
3. Remove trim strip under door insert and unscrew trim strip.
4. Remove door weather strip.
5. Remove ornamental strip together with side paneling.
6. Undo and remove rear paneling.
7. Unscrew rear vent window at hinge pillar and roof frame and remove.
8. Unscrew trim strip.
9. Unscrew striker plate. Undo rear lid cable from left-hand rear fender and remove.
10. Remove rear window glass.
11. Partially detach roof lining.
12. Unscrew cover strip and remove treadplate covering.
13. Partially detach carpet on side member and roll back.

Removal

1. Chisel off lock pillar along wheel arch as far as fender top edge.
2. With chisel break joint to sill plate.



Fig. 163

3. Chisel off edge round rear vent window up to top end of rear curve. Then cut through at right angles to roof.
4. Chisel off along guttering for lid as well as joint plate for rear cross member. Remove fender.



Fig. 164

5. On left-hand rear fender remove guide tube for lid cable from moulding.
6. Remove remaining pieces of metal with welding torch and clipper.
7. Bend up beaded metal along guttering and remove.
8. Clean soundproofing compound, paint and rust off the wheel arch panel, door sill and rear crossmember at the joints with the new fender with wire brush, scraper and welding torch.
9. Wash anti-rust compound off new fender.

Fitment

1. Trim new fender roughly to line up with lock pillar using old fender.
2. Secure fender with clamps. At the same time insert the guide tube for the lid cable into the moulding along the left-hand fender.
3. Close doors and locate the new fender in relation to the door top edge and gap with door and then starting at the top tack with oxyacetylene torch.
4. Tack fender at end of gutter.
5. Spot weld lock pillar to wheel arch with tongs working from top to bottom, constantly lining up the gap and the face of the fender with the door. Screw on striker plate.
6. Trim fender for abutment, fit template for rear vent window and then weld fender.
7. Tack on gutter at bottom end lining up with lid. The fender edge towards the light box must be flush with the underside of the lid.
8. Spot weld rim on rear vent window as well as gutter along lid cutout with welding tongs to make watertight.
9. Tack fender onto door sill, jack socket and rear cross member with oxyacetylene torch. Attention should be paid to alignment of the wheel cutout.

10. Make further joint with spot welder.
11. Bead wing on gutter and weld at top and bottom ends.
12. Fill and rub down visible weld spots together with joints in door and lid gaps, door sill and rear crossmember. Check dimensions with gauges P 1000 and P 1001.



Fig. 165

13. Fit rear bumper and quarter bumpers.
14. Fit rear lights. Attach bumper override.
15. Fit trim strip on rear vent window.
16. Prepare vehicle for necessary cellulosing. Spray with underseal.

Special tools:

Rear vent window template
 P 1000 Door flange gauge (own construction tool)

P 1001 Door and lid gap gauge (own construction tool)

Preliminary operations

Dismantle as far as necessary as described under 36 80.

Removal

1. Chisel off lock pillar along wheel arch up to fender top edge.
2. Chisel off joint on door sill and on jack socket.
3. Chisel off fender along rim up to bottom radius of rear vent window.
4. Mark out and trim from center of wheel arch vertically up to rear vent window.

5. Remove damaged section. In addition disengage the lid cable from the left-hand rear fender and part guide tube from moulding.

6. Remove metal remains. Clean paint, sound-proofing compound and rust from wheel arch panel, door sill and fender joint.

7. Rectify bent metal sections.

Installation

1. Trim new section roughly to about 3 cm (1.2") overlap.
2. Line up fender in relation to door height and gap as well as with rear vent window template and secure with clamps.
3. Mark out overlap with scribe.
4. Remove fender and trim.
5. Tack lock pillar at top to line up with door.
6. Fit rear vent window template and tack fender along edge.



Fig. 166



Fig. 167

7. Tack fender along rim with old section.
8. Spot weld lock pillar starting at top. When doing this constantly check alignment and gap with door and rectify if necessary.
9. Spot weld fender onto door sill.
10. Weld bottom to jack socket.
11. With oxyacetylene torch weld the new section at a distance of approx. 2 cm (0.8") on the existing fender section.
12. Align tacking points and weld through.
13. Dress weld seam and file down with metal plane.
14. Rectify, fill and rub down all irregularities and dimensional variations. Check with gauges P 1000 and P 1001.
15. Prepare vehicle for cellulosing and renew under-seal where damaged.



Fig. 168

PARTIALLY RENEWING FENDER

38 80

Special tools:

P 1001 Door and lid gap gauge (own construction tool)

Preliminary operations

Dismantle as far as necessary as per 36 BO.

Removal

1. Mark out and cut off fender in front of or behind fender stay up to lid cutout.
2. Chisel off gutter along outside edge together with joint plate to rear cross member.

3. Detach damaged fender section. Remove any metal remains from spot weld joints.
4. Remove sound-proofing material, paint and rust from wheel arch panel, rear crossmember as well as from old fender at joint faces.
5. Trim new fender (without lock pillar) to leave approx. 3 cm (1.2") selvedge and wash off rust-proofing compound.



Fig. 169

Installation

1. Secure fender with clamps.
2. Close rear lid. The fender edge along the light box must line up with the bottom edge of the lid. The gap with the lid should be 4 mm (0.16").
3. Scribe fender, remove and trim.
4. Tack fender with oxyacetylene torch to existing section beginning along the edge nearest the lid gap.
5. Tack gutter and joint plate to rear cross member lining up with lid.
6. Weld fender through and dress.
7. Spot weld gutter as well as joint plate.
8. Check gap with lid with gauge number P 1001 and rectify any variations.
9. Clean, fill and rub down all weld spots and irregularities.
10. Fit rear bumper and quarter bumpers.
11. Attach bumper override.
12. Fit brake/rear light. The light as well as the quarter bumper should fit snugly against the override. When these components fit properly detach.
13. Prepare the car for cellulosing and renew any damaged underseal.



Fig. 170

Preliminary operations

1. Strip car for placing on Celette rig.
2. Remove front and occasional seats with back-rests.
3. Remove heel board carpet.
4. Partially detach both side member carpets.
5. Roll back side member carpets and side paneling.
6. Remove sound-proofing material completely from heel board and partially from seat moldings and side members.
7. With a chisel open up both seat moldings along the side member starting at the heel board on three sides approx. 15 x 15 cm (5,9 x 5,9").



Fig. 171

8. Bend the metal back so that the transverse tube is accessible from above.
9. Remove or mask off any cables and fuel and brake lines that are likely to be damaged.

Removal

1. On vehicles whose rear axle transverse tube is welded to the heel board at the moldings, the transverse tube should be cut through here with the cutting or welding torch.



Fig. 172

2. Completely cut through the transverse tube outside the bearing supports so that the center section is free and can be detached.



Fig. 173

3. With the welding torch cut off the side members around the immediate vicinity of the transverse tube.
4. Cut through the right-hand side member at the rear to a tube thickness of approx. 5 cm (1.9") and bend back.

5. With a flame cutter cut through the transverse tube approx. 10 mm (0.40") inside the outer weld seam.



Fig. 174

6. Pull the stumps of the transverse tube backward and forward to loosen the adhesion points between the side members.
7. Knock the stumps out towards the center.
8. Burn off remains of tube and remove.
9. Rectify the plates bent by removal of the transverse tube and grind off any weld beads remaining. On vehicles which have the moldings in the heel board these should be welded too.

Installation

1. The new transverse tube should be pushed through into the side member which has been cut open until it can then be pushed into the side member on the other side.



Fig. 175

2. Line up any projecting metal pieces with the tube.
3. Place body on Celette rig.
4. Adjust and secure all support points of the body including the rear axle transverse tube on the Celette rig.



Fig. 176

5. The transverse tube should be oxyacetylene welded in position where accessible.
6. After the weld spots have cooled release support points.
7. Lift body at the rear until the transverse tube can be completely welded.

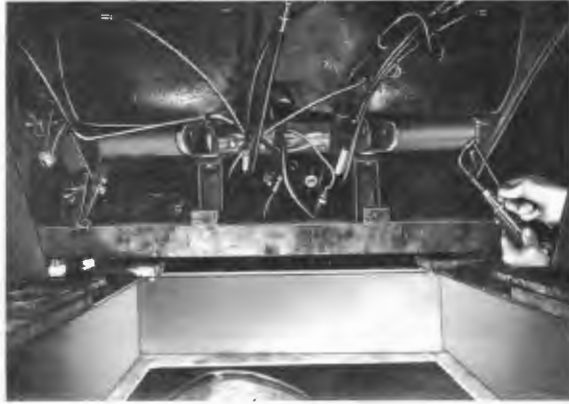

Fig. 177

8. Bend back metal sections of seat moldings that were cut open, line up and weld.

9. Check tube ends for proudness and if necessary grind off.

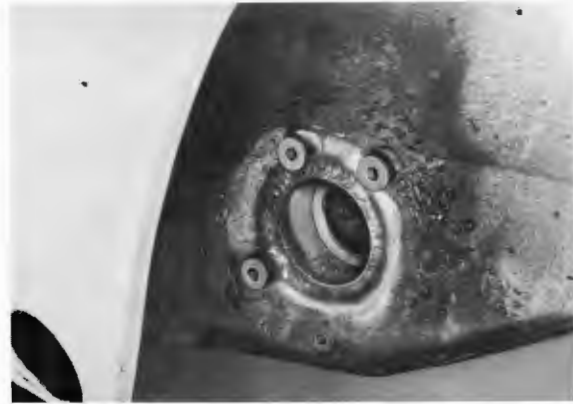

Fig. 178

10. Check body for truth on Celette rig.
11. Primer the weld points, renew damaged under-seal and reassemble the car.

General

No universally applicable operation instructions can be given for the repair of a body as each repair is different and requires individual treatment. It is of course understood that this work will be carried out by a specialist. The instructions given here should therefore be treated as a guide only.

Body operations

1. Detach sections of exterior paneling rendered unusable by damage.
2. Place body on Celette rig and secure at the undamaged support points.
3. With the Dozer and hydraulic press including accessories the damaged body sections should be pulled or pressed back as far as possible to their original location and shape. Here it should be ensured that the distortion is wherever possible pulled back in the same direction in which it occurred. In this way it is possible to rectify distortion which - in the case of panel sections cut off immediately - could only be returned to the original position with difficulty.
4. Cut off the panels no longer serviceable. Generally it is simplest to do this with a flame cutter or welding torch.



Fig. 179

Preliminary operations

Strip the car for placing on the Celette rig. According to nature and extent of damage fully or partially remove glass, seats, occasional seats with rests, roof lining, carpets and other covering, bumpers, doors, lights, trims, etc.

5. Remove metal particles from spot welds with clippers and welding torch.
6. By measuring, which should be carried out corner to corner, it should be checked what distortion exists, further operations can then be carried out on the basis of this.
7. All locations points of the body must seat on the Celette rig and be capable of securing without strain. Here the dimensions with tolerances should be noted.
8. The weld spots with the new components should be cleaned with a welding torch, scraper and wire brush, removing sound-proofing compound, rust and paint.
9. The weld spots should be trimmed so that the joint with the new sections is as short as possible.
10. Before reassembly straighten all distorted panels and rectify to size. This work can be facilitated and carried out with extreme accuracy on doors and windows by means of gauges. The previous operations are essential before reassembly.
11. Wash rust-proofing compound off new sections. Offer up new sections and trim in accordance with old sections.

Reassembly

1. Reassembly should begin with fitting of the doors. Here it should be checked that the doors have the necessary gap all round. The distance of the door inner edge to the flange must be 9 mm (0.35") all round inclusive of the door window frame. Check with gauge P 1000.
2. During this operation distortion and other dimensional variations may become apparent. These should be rectified at this stage.
3. The cutoff sections - side members, wheel arch panels, rear panel, crossmember, engine supports, etc. should be attached in sequence on the Celette rig. The side members and wheel arches should be oxyacetylene welded at the weld spots with the old sections and aligned.



Fig. 182

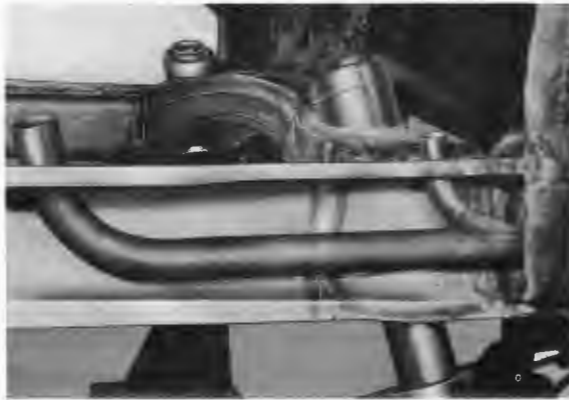

Fig. 180

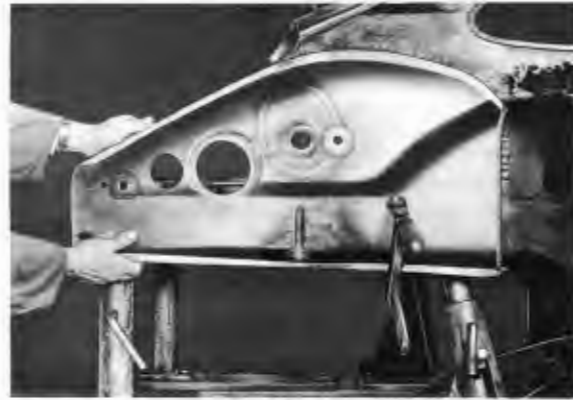

Fig. 183



Fig. 181

4. Allowance should be made for distortion that may occur due to welding.
5. The joints of the sections to each other should be made with the spot welding unit. Here as far as possible because of the high durability one should work with the spot welding tongs.
6. The seams should be checked for tightness and durability.
7. It should be ensured that dimensions are kept within tolerances.

Preliminary operations

1. Disconnect battery. Remove engine and fuel tank.
2. Remove seats, occasional seats with backrests, door panels, trim strips, side and rear paneling and rear compartment carpet.
3. Unhang doors.
4. Remove windshield and rear window glass together with vent windows. Remove trim strips for vent windows.
5. Remove interior mirror, sun visor, dashboard paneling, interior lights and pull out cables.
6. Remove screenwiper arms, detach steering wheel.
7. Remove front and rear lids.
8. Remove weather strips from door cutouts.
9. Pull off roof lining along roof frame, release wire stays and remove lining together with pillar paneling.
10. (Applicable only to sliding roof)
Remove sliding roof cover, top frame, motor with gear, tubular bracket with drive shaft, guide rails and cable covers with wind deflector.

If the center section of the windshield frame has to be removed it will be necessary to remove additionally the front fenders, the water trough and heater hoses, wiper unit, screen wash jets, the cover plates for heater nozzles, the lid seal, luggage compartment carpets and the lid hinges with pneumatic springs. The center section of the windshield frame should be chiselled off from the wheel arches and the dashboard top section. The roof frame should also be parted off at the wheel arches and the hinge pillars.

Body operations

1. Saw through windshield frame approx. 5 cm (1.9") above dashboard.



Fig. 184

2. Saw through roof frame at top end of lock pillar.

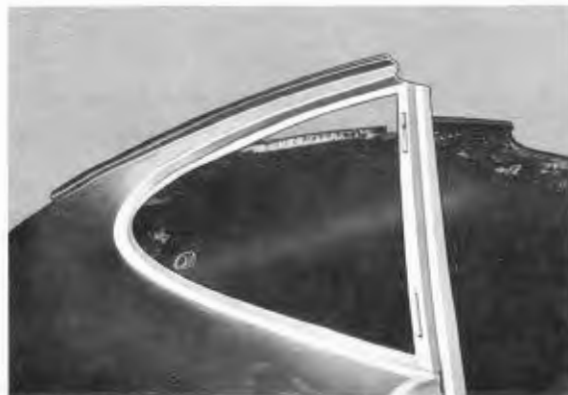

Fig. 185

3. With a welding torch heat the flange edges of the guttering starting from the lock pillar and working backwards so that the edge does not break off when bent up. Bend up flange edges.
4. Chisel off the roof frame along the rim of the rear vent window and from the wheel arch panel.

5. Chisel off the rear roof fillet on both sides of the rear panel.



Fig. 186

6. Cut through the roof exterior panel with the welding torch from the lock pillar to the rear fillet above the gutter and detach the damaged roof.
7. Remove all metal remnants with clippers and welding torch. Rectify distorted panels. Clean weld points and joint plates.

Reassembly

1. Trim and match up the two roof frames with the windshield template, secure with clamps and oxyacetylene weld.
2. Tack the roof frames along the rear wheel arches.



Fig. 187

3. Weld roof frames to lock pillars.
4. Insert windshield crosspiece using windshield template, secure with clamps and spot weld and weld to the roof frames.



Fig. 188

5. (Applicable only to sliding roof)
Offer up water drain tubes, drill roof frames, insert tube and weld in position.



Fig. 189

6. Solder rear water drain tubes along side pillars of roof exterior panel to rear window. Weld bottom orifice of tubes to exterior panel.

Note!

The rear outlet of the water tubes should no longer be taken along over the side of the gutter but into the gutter underneath the rear lid.



Fig. 190

7. Cut off the center section of the windshield frame in accordance with trimming of old roof.



Fig. 191

8. Place roof in position, secure with clamps and tack in position with oxyacetylene torch in accordance with window templates and door window frames.

9. All joints of the roof to the roof frame and rear panel should if possible be spot welded with the spot welding tongs. Spot weld the roof in the gutter at a distance of approx. 5 cm (1.9"). If copper strips are used indentations due to the spot welds will be avoided.



Fig. 192

10. Weld the windshield pillars, lock pillars and rear joint fillet in the guttering on the engine compartment.
11. Bead the gutters, weld at the ends, dress and file to size.
12. Insert windshield, rear window and rear vent window templates and line up cutouts and rims.

Paragraphs 13 - 22 applicable only to sliding roof

13. Attach sliding roof frame right round the top with Terostat strip.
This ensures satisfactory seal with the roof and at the same time eliminates noise.
14. Insert the sliding roof frame, press against the exterior panel with suitable strips of wood and clamps.
15. Line up the cutout for the sliding roof with the sliding roof frame at front and sides and spot weld including the radiuses.
16. Lip the rear rim with the radiuses around the sliding roof frame.



Fig. 193

The transition points from the sliding roof cover to the roof cutout must line up all round. The gap between the two components should be 4 mm (0.16") at front and sides and may be 6 mm (0.23") at the rear.

17. Spot weld the gear bracket on the rear roof frame.
18. Match up and spot weld two metal stays 260 mm (10.2") to the side of the roof center from windshield crosspiece to sliding roof frame.
19. At the sides it is also necessary to match up and fix two stays approx. 160 mm (6.3") in front of and 60 mm (2.4") behind the interior light.

20. Fix the tubular bracket on the sliding roof frame.



Fig. 194

21. Push the water pipes over the tube ends, seal and secure with hose clips.
22. Install sliding roof with rails, guides, wind deflector, drive cables and electric motor with gear as described under sliding roof installation and check for function and dimensional accuracy. If necessary rectify.
23. Rub down all visible weld spots and other irregularities, fill with solder and rub down.
24. Check the window cutouts once again with the window templates. If necessary rectify..
25. Fit mouldings for door weather strips to give 9 mm (0.35") clearance from the window frames.
26. Detach sliding roof with guides and prepare the vehicle for the necessary cellulosing.

Adjusting folding top

1. Unclip folding top, remove and slacken.
2. Check catches and renew if necessary. For this purpose detach the plastic covering of the Allen screws, slacken the screws, lift off hinges and push catches downward and out.
3. Insert new catches and screw in position.
4. Tension the folding top. Lay a straight edge across the front or rear outer hinge pins. The distance from the straight edge to the center hinge pin must be 42.5 mm (1.67") at the front and 43.5 mm (1.71") at the rear.



Fig. 195

5. In the case of dimensional variations slacken the catch, adjust as necessary and retighten.
6. If the hinges of the roof frame make any noise the locking rings of the hinge pins should be pulled off and the hinge pins removed.

7. Deburr the edges of the hinges (with a file) and slightly grease before reassembly: renew damaged hinge pins.



Fig. 196

8. Place top in position and check that the catches lock properly and do not rub in their guides. If necessary open out guides slightly with a file or rectify catch hook. To increase the contact pressure of the top against the windshield top section the locating holes for the catch hooks can be bent downwards slightly.
9. Check front and rear fixing bolts for wear and renew if necessary.

Note

The folding top 901.565.002.40 can be replaced by the lighter folding top 901.565.002.41.

Sealing operations

1. Check Silentbloc and if damaged or not flush with the sealing strip detach and renew. For this purpose the interior cover plate of the roof bar should be removed.
2. Tap the Silentbloc out to the rear with a suitable drift.
3. Tap in Silentbloc 901.565.220.40 with the elongated funnel shaped hole in from the rear and peen over with a chisel. Cement in sealing strip for Silentbloc.



Fig. 197

4. In the case of damage or leakage of the sealing strip on the safety bar or on the windshield frame these should be renewed. For this purpose pull the sealing strip out; carefully remove all remains of adhesive.
5. Cement sealing strip on roof bar starting at the Silentblocs so that the rear sealing lip is a uniform 6 mm (0.24") under the bottom edge of the roof bar. If necessary cement a suitable rubber strip under the sealing strip.
Note! It is essential to ensure that the sealing strip is cemented over its whole length to form a watertight joint. Terokal T 2444 rubber molding cement has been found satisfactory. Please note maker's instructions.
6. Place the folding top in position. The top must be flush with the roof bar top edge and must seat properly on the rubber molding over the entire length.



Fig. 198

7. Mark out recesses in the side of the sealing strip for the door window seals on the roof bar covering and cement accordingly.



Fig. 199

8. Cement the bottom ends of the covered rubber molding so that they seat properly on the top edge of the door. For this purpose stretch or compress the rubber molding as necessary.
9. Trim the bottom joint face to the door sealing strip to form a butt joint and cement together.
10. Tap in plastic plugs and rivets on Silentbloc. Check water drain passages for correct operation and if necessary blow through with compressed air.
11. Renew sealing strip on windshield frame. Fitment should begin at the corners of the frame to ensure accurate seating of the rubber.
12. Trim the bottom joint face to the door sealing rubber to form a butt joint and cement in position. The thick bottom edge of the molding must seat properly on the top edge of the door and should not stick.
13. For covering along the windshield top section fit the new continuous sealing strips 901.555.559/560.40 with non-rusting self-tapping screws 3.5 x 9.5 DIN 7973-St.
14. Tap in plastic plugs and rivets. Check water drain passages in molding for correct function.
15. Place top in position, close door windows and check the seal of the sealing strips.
16. If the top edge of the windshield does not seat properly on the rubber, slacken the support rails and push outwards as necessary, drill fresh holes so that the windshield glass presses against the seal. Where small corrections are necessary the support rails can be rectified slightly.



Fig. 201



Fig. 200

17. Submit the car to a thorough water test. Rectify any small faults.

Removal

1. Detach folding top.
2. Remove trim strips.
3. Unclip interior lights. The inside covering of the safety bar should be unscrewed at the bottom and removed to the rear.



Fig. 202

4. Undo trunk clips with short or flexible shaft screwdriver together with the other screws in the top rear section and remove top rear section.
5. Unscrew the top of the top rear section.
6. Release top handles, open zipper and unscrew eccentric plate of top handle.
7. Remove eyebolts of rear bar from angle brackets.
8. Undo screw fixings of rear and clamping bars in the corner formed by the top edge of the fender and the safety bar, and remove.



Fig. 203

9. Push the clamp bar of the top rear section down and then pull out of the safety bar first upwards and then downwards so that the top rear section can now be removed to the rear.



Fig. 204

10. Unscrew top handle.

11. Chisel off the angle bracket from the top section of the rear panel.

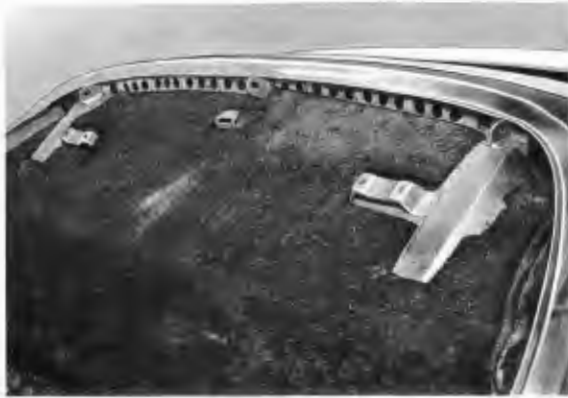

Fig. 205

12. Pull off seals in front of and behind the safety bar covering.

13. Unscrew and detach covering (chromed plate) of safety bar.

14. Unscrew Tenax knobs and if desired seal the holes with short self-tapping screws or extend the holes and seal with solder or weld and solder over.

Cellulose or touch up any paint scratches.



Fig. 206

Installation

1. Secure cage nuts for top handles with 6 mm (0.24") screws to prevent rattling.

2. Seal holes for tubular bar fixing with sealing plugs.

3. Fit trim strips along fender top edge, drill, seal with Terostat strip, place moulding underneath and secure with roundhead countersunk self-tapping screws. Secure bolts at front with washers and self-tapping nuts.



Fig. 207

4. Pull sealing frame and bezel onto glass. Pull a cord into the sealing frame and insert glass.



Fig. 208

5. Seal and clean rear window glass.
6. Place safety bar covering in position and screw up.
7. Fit seals on both sides of safety bar and cement in position. Additionally secure front seal with plug and plastic rivets.
8. Align rear tabs on safety bar.
9. Attach new inside covering on safety bar.
10. Connect up interior lights and insert.
11. Fit new rear panel top section.
12. Attach rear paneling with trunk clips.
13. Attach new trim strips.
14. Check car for leaks. Carry out water test.

Note

On USA vehicles it is now permissible to install complete occasional seats instead of the luggage shelf.

This conversion is possible as from chassis no. 118 50065
 118 55016
 118 60062
 118 70040
 118 80036
 128 70207

The following material is necessary for subsequent installation:

1	Green tinted rear window	901.565.551.45
	or "heated" 100 W green rear window	901.565.551.50
1	Sealing frame	901.565.052.40
1	Seal for rear of safety bar	901.565.930.41
1	Left-hand trim strip	901.565.555.40
1	Right-hand trim strip	901.565.556.40
1	Cover plate	644.541.921.06
1	Left-hand trim strip cover	901.565.561.40
1	Right-hand trim strip cover	901.565.562.40
1	Inside cover	901.565.017.42
1	Left-hand trim strip	901.555.091.42
1	Right-hand trim strip	901.555.092.42
8	Roundhead countersunk self-tapping screws	900.143.038.02
2	Countersunk self-tapping screws	900.144.009.00
2	Sealing plugs (foam rubber)	901.565.563.40
1	Front seal for safety bar	901.565.091.40
1	Rear panel top section	901.555.096.42
4	Plugs	991.591.520.40
4	Plastic rivets	991.591.521.40
4	Self-tapping nuts	999.591.340.02
4	Washers	900.151.006.40
app. 2 m (6.5')	Terostat strip	999.911.088.50
app. 2 m (6.5')	Molding for trim strip	

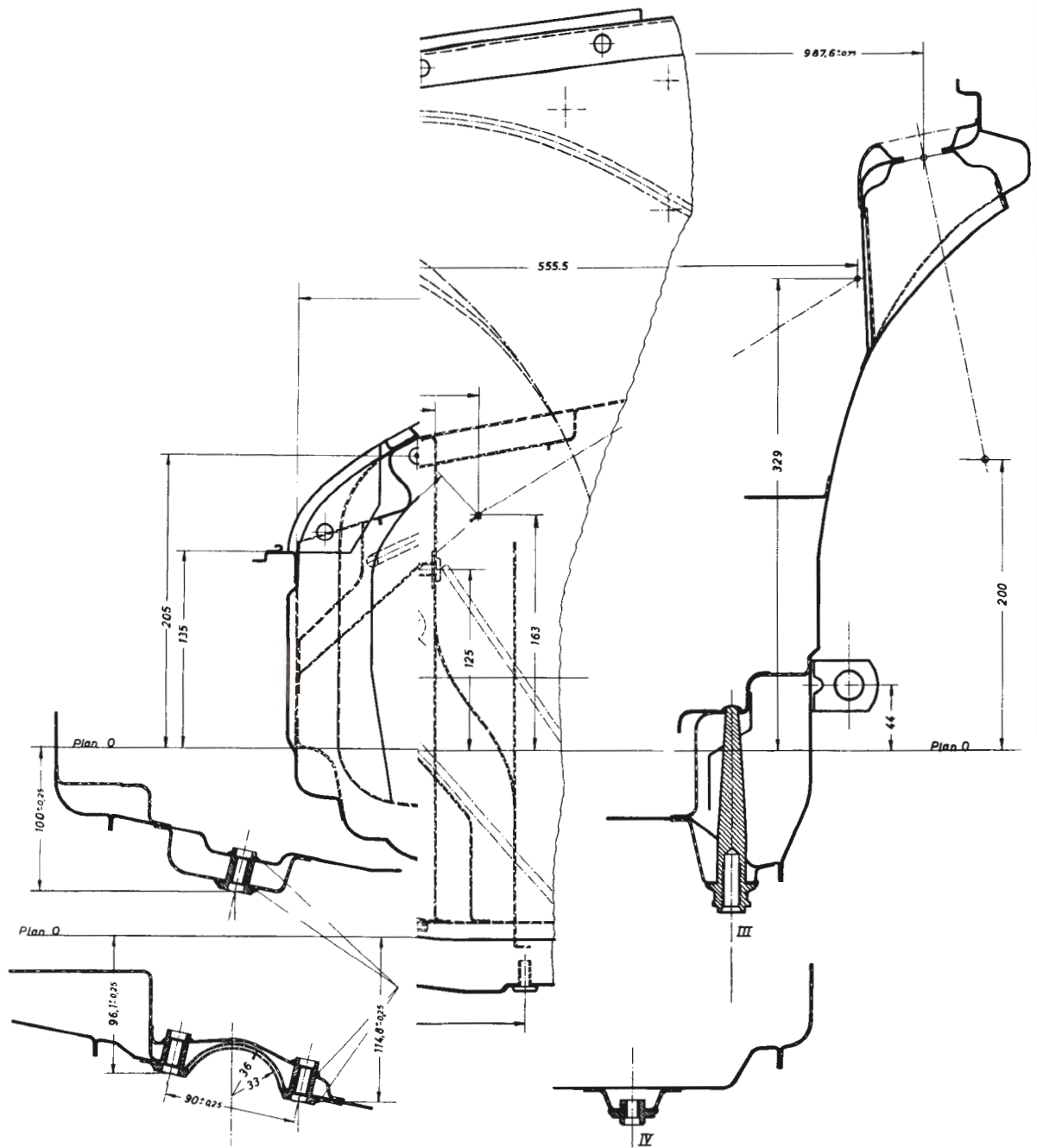

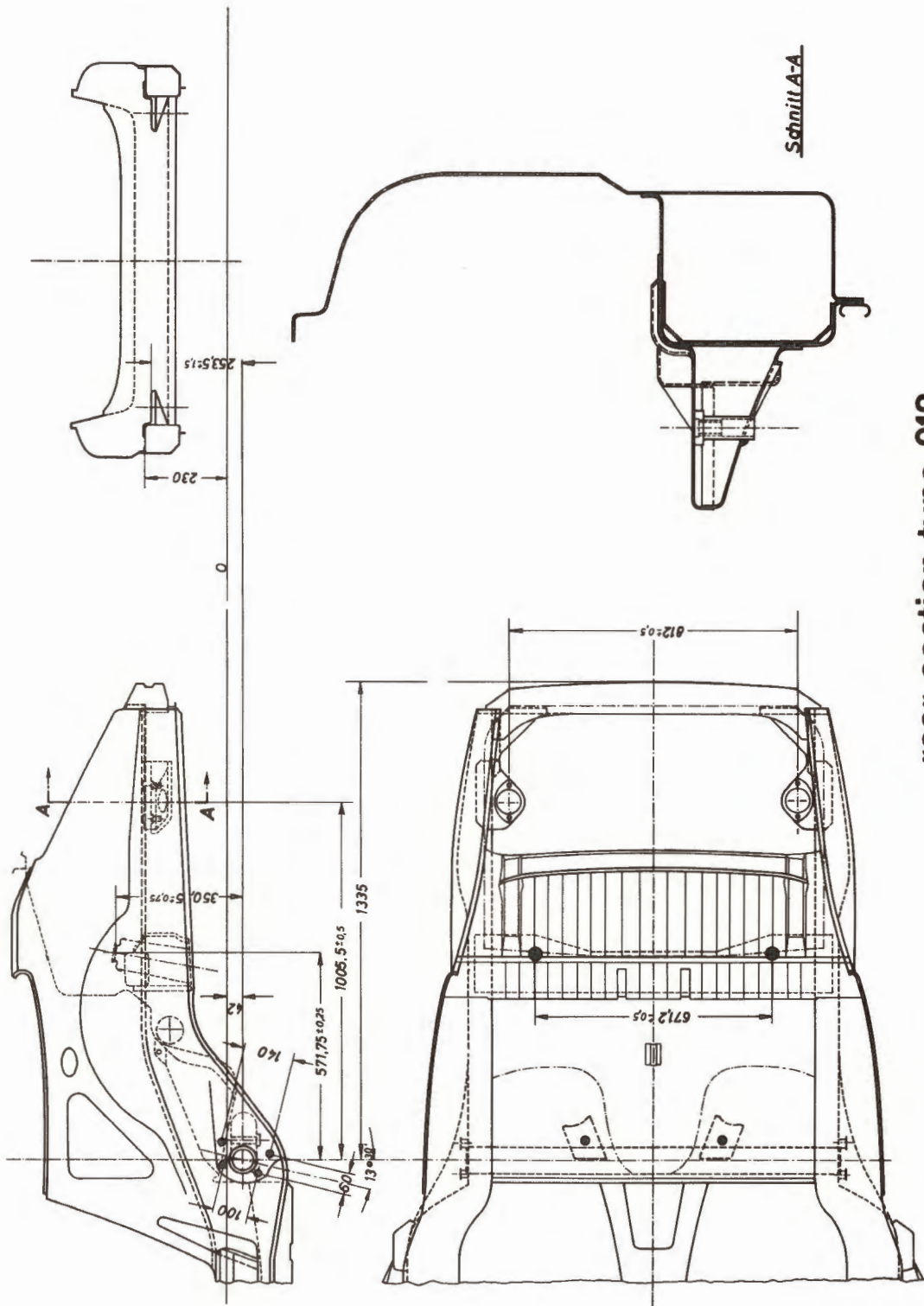

rear section type 912

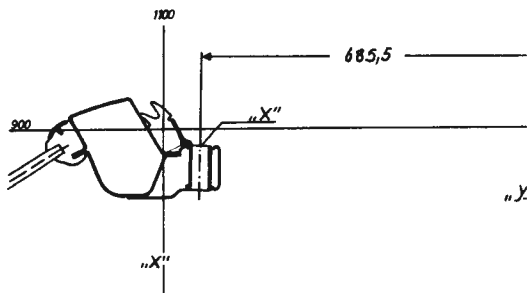
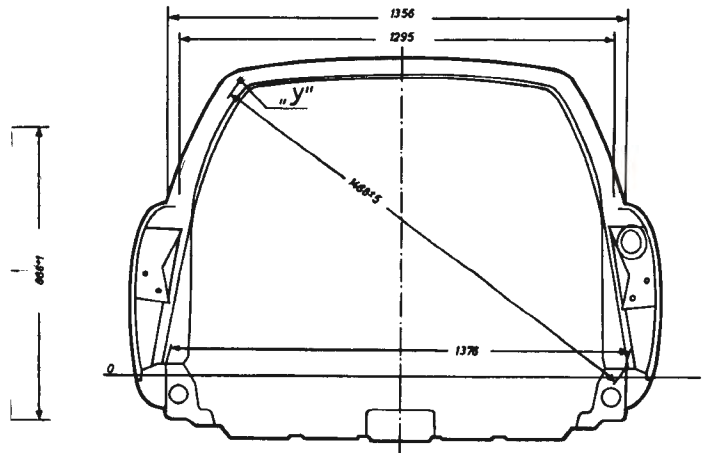
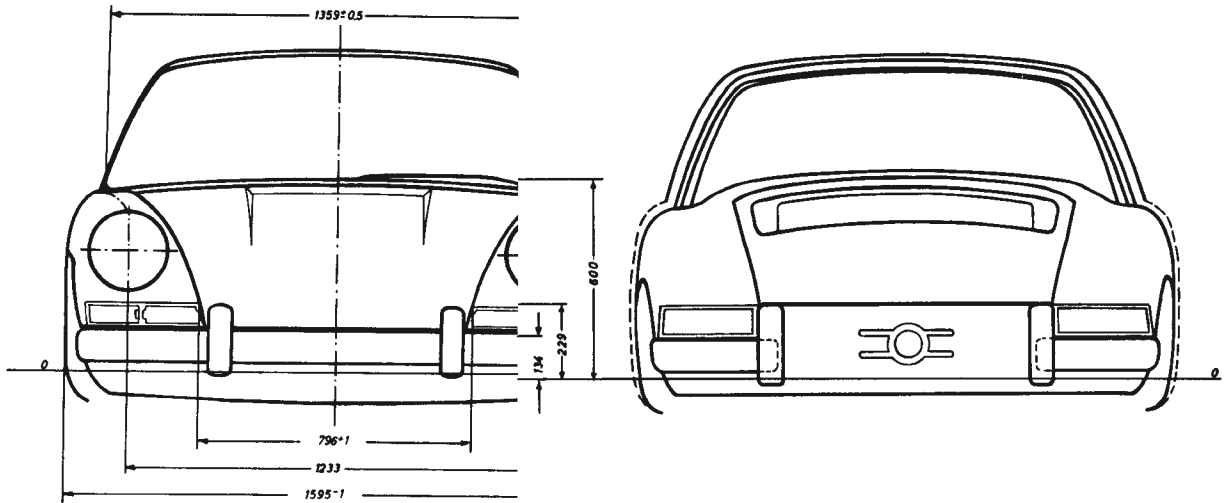

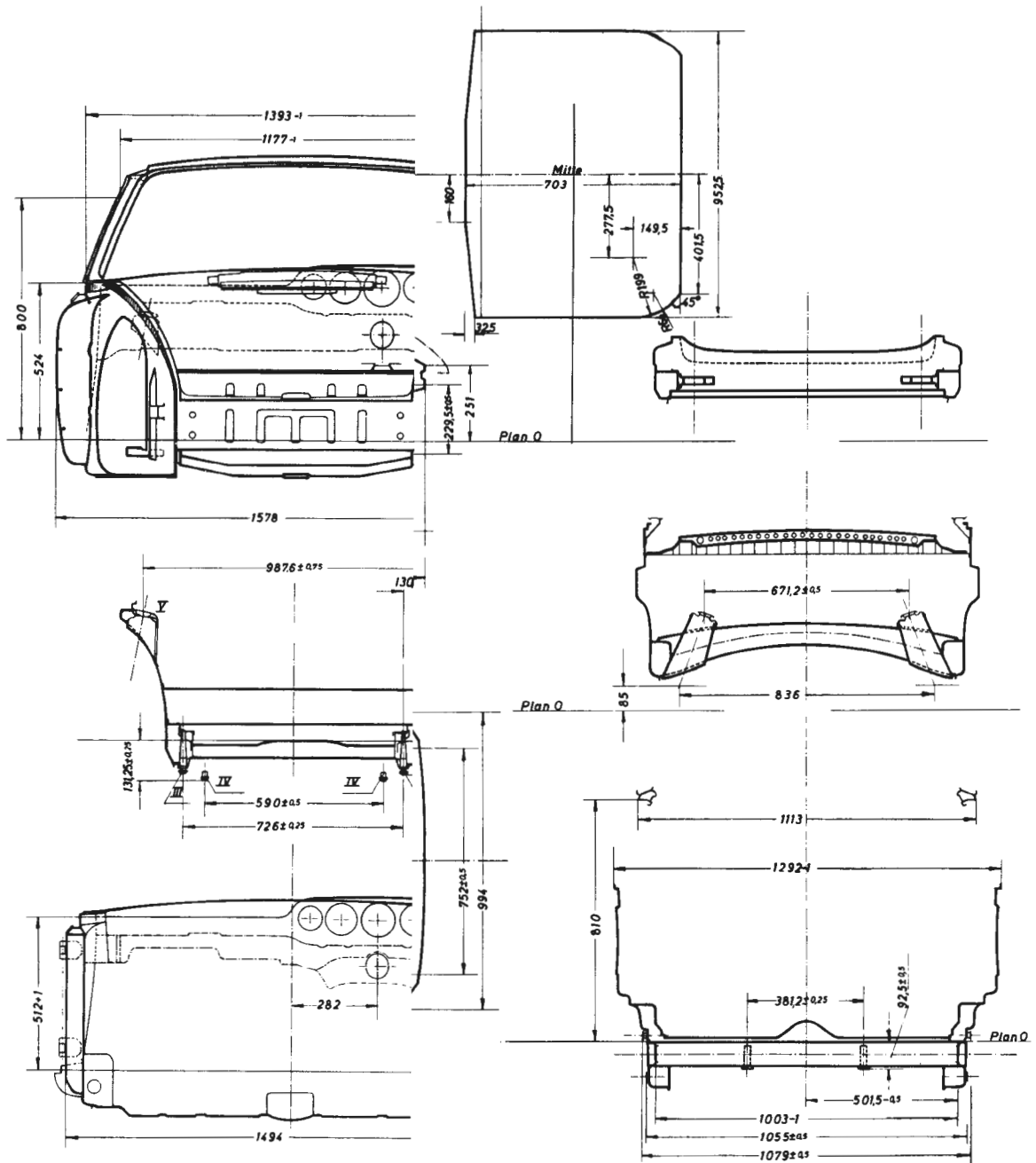

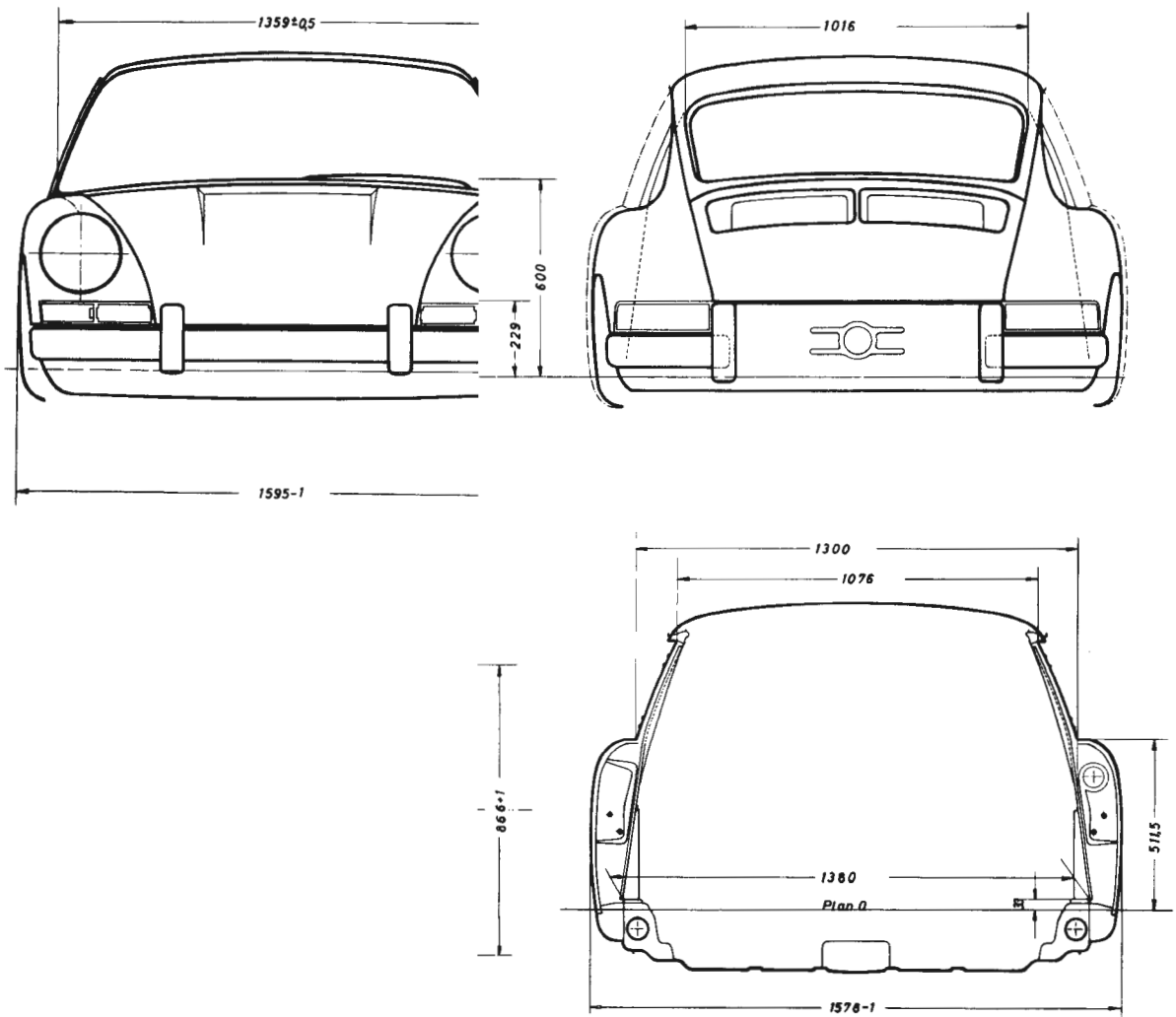

instructions

PAINTWORK

General

Since January 1956 synthetic resin paints have been used exclusively for all Porsche vehicles. The original paintwork is denoted by a color plate on the left-hand door hinge pillar below the chassis number.

The paintwork operations described below are intended to clarify the procedures used for Porsche vehicles and should in this sense be regarded as guiding principles. It is recommended to keep to the instructions of the makers of branded paints regarding use, spray viscosity, nozzle widths of spray gun as well as spray pressure.

Work bays and special instructions

Certain conditions must be observed during workshop operation:

The spray booths and drying ovens must be clean and dust free.

Note! It is forbidden to spray nitro and synthetic resin paints alternately in the same booth.

The clothing of the spray operator should be non-fray and should be coated with dust-attracting compound.

Only non-fraying paper should be used to mask the body during final painting.

Newspaper is unsuitable for this purpose.

When partially or completely repainting vehicles it should be ensured that all sections are free from silicone and way residues.

Whenever painting is carried out with oven-dried synthetic resin paints above 90°C (194°F) all component parts such as lights, fittings, radio, fuel tank, celluloid and plexiglass components, together with wiring, textile and rubber components should be removed.

Normally three types of synthetic resin paints are used:

1. Air drying synthetic resin paints.

By virtue of their low hardness these are only suitable for small paint jobs.

2. 80°C (176°F) baking paints.

Essentially these possess all the advantages of the new 140°C (284°F) baking paints but the resultant finish is not so hard. In general 80°C paints should be used for all repair paint jobs.

3. 140°C (284°F) baking paints.

These paints are used for out new cars and where suitable ovens are available can be utilised for re-painting. For this purpose all heat sensitive parts must be removed.

Repainting

For repainting over existing paintwork proceed as follows.

Cleaning:

Scrutinize old paintwork for condition. Completely remove and rub down where paint is damaged or flaking off. To remove the film resulting from polishing the parts in question should be cleaned with benzine, silicone remover or a similar material.

Priming:

1. In places where the paint has been rubbed right down clean and spray with Aktiv primer.

Air drying time: 1/2 hour.

Oven drying time: 10 minutes at 40°C - 50°C (104°F - 122°F).

2. With damaged areas which have been rubbed down and primed fill if necessary up to 4 times.

Air drying time: 4 - 5 hours.

Oven drying time: 1 hour at 40°C - 60°C (104°F - 140°F).

3. Rub down filled spots with number 240 emery paper.

4. Spray with gray spray filler in 1-2 passes.

Air drying time: 6 - 8 hours.

Oven drying time: 1 hour at 70°C - 80°C (158°F - 176°F).

Leave for 10 minutes before drying to permit evaporation.

Rubbing down:

Rub down body initially with wet abrasive paper No. 360.

Rub down body finally with wet abrasive paper No. 500.

Painting:

Before painting is carried out careful cleaning of the rubbed down body is essential. To prevent water spots the body must be carefully leathered and the flanges and gaps blown through with compressed air. The body should then be cleaned and dusted with anti-dust cloths. This ensures that when spraying neither dust nor dirt and water can spoil the paint finish.

Spray on synthetic resin enamel (with thinner) in desired color shade in one pass. According to the workshop equipment use air or oven drying paints. The paint film should not be applied too thickly (max. 0.04 mm/0.0016").

Metallic finish paints should be sprayed in several passes according to the covering power of the paint. Increase the distance from the spray gun to the spray surface to avoid any running (drier spraying).

Air drying time: approx. 12 hours.

Oven drying time: 1 hour at 70° - 80° C (158° - 176° F)

Allow ten minutes for evaporation between spraying and drying.

Note:

The full hardening effect, particularly in the case of air drying paints, does not take place until several days later. To increase resistance to scratching it is recommended that the body should subsequently be treated with preservative. The preservative should be applied thinly with a soft pad and then after drying off should be rubbed down with a clean pad.

In the case of partial repainting careful color matching should be carried out as the paint when ageing according to color shade will fade and weather differently. It may therefore be necessary even with the same paints to carry out reshading. If necessary prepare a paint sample on a suitable sheet of metal.

With partial repainting there is the risk that the shade of the repainted sections will alter after a certain time as a result of fading and will thus no longer match the other paintwork. (Caused by different oven temperatures.)

Color coding:

Example: synthetic resin paint 6402

The two figures 64 denote the 1964 color range.

The figures 02 denote ruby red in this color range.

The figures 01 - 09 are standard production colors in the range concerned.

On the other hand 6413 is black and thus a special color in this catalog.

The new color coding has additionally two prefix numbers and a suffix letter after the coding, e.g. 97 - 6802 - L.

The number 97 is an index number of the paint manufacturer concerned and here signifies 140°C (284°F) paint from Messers. Lesonal, who are denoted by the suffix letter L.

L = Lesonal

G = Glasurit

H = Herberts

The 1967/68 color range consists of the following standard colors:

Slate gray	6801
Polo red	6802
Ossi blue	6803
Light ivory	6804
Bahama yellow	6805
Irish green	6806
Sand beige	6807
Burgundy red	6808
Tangerine	6809

In addition the following 22 special colors are available:

Ivory	17657	Bush green	62163
Champagne yellow	16153	Dark green metallic	62109
Signal yellow	R 1007	Turkey green	R 6016
Lemon yellow	R 1012	Grey white	75742
Dark red metallic	30847	Fortuna gray	R 7030
Crystal blue	52254	Beige gray	70192
Pastel blue	R 5012	Olive	62166
Blue metallic	52300	Sepia brown	R 8007
Ultra blue	R 5013	Coffee brown	80342
Lime green	62165	Black	95043
Signal green	R 6001	Silver metallic	96024

R = Ral, ist obtainable from all manufacturers under this number.

For the 1966 models the following were standard colors:

Slate gray	6601
Polo red	6602
Gulf blue	6603
Light ivory	6604
Bahama yellow	6605
Irish green	6606
Sand beige	6607
Aga blue	6608
Black	6609 plus 22 special colors.

For the 1964/65 models the following were standard colors:

Slate gray	6401
Ruby red	6402
Enamel blue	6403
Light ivory	6404
Champagne yellow	6405
Irish green	6406
Signal red	6407 standard color and
Dolphin gray	6410
Togo brown	6411
Bali blue	6412
Black	6413 special color.
